

HOOLIGAN 170I SERVICE MANUAL

This manual offers all service specialists with the technological procedures of maintenance, repair, and troubleshooting for the Hooligan 170i.

- **Four-Stroke Cycle, 168CC , 2-valve, electronic injection, Oil-cooled engine.**

Contents

This manual is a service manual for Hooligan 170i with details specifying skills to disassemble or install various mechanisms, basic maintenance (check and adjustment) of components, notices for operation, and configuration of colored electrical wires in connection with the motorcycle in which there are 7 chapters and as references of users or mechanics during service.

Classification	Item	Page
Information summary and preparation	1	3~21
Installation or Removal of External Components	2	22~45
Check & Adjustment	3	46~64
Fuel Injection System	4	65~81
Engine / Reverse differential gear	5	82~118
shock absorber / brake system/wheel	6	119~129
Cylinder Assembly	7	130~146
wiring		

Information Summary and Preparation –1

1-1 Specifications

SCOOTER SPECIFICATION							
BRAND		Genuine	FRAME		STEEL TUBE		
MODEL		Hooligan 170i	SUSPENSION	FRONT	TELESCOPE		
LENGTH		1870 mm		REAR	UNI-ABSORBER		
SCALE	WIDTH		TRANSMISSION	1 ST REDUCTION		2.65~0.81	
	HEIGHT			2 ND REDUCTION		9.262	
	WHEEL BASE			CLUTCH		CENTRIFUGAL	
	FRONT			GEARBOX		C.V.T.	
REAR		TYRE		FRONT	120/70-12		
MASS	TOTAL		REAR		130/70-12		
	RIDER		BRAKE	FRONT		DISK	
	FRONT			REAR			
	TOTAL MASS	REAR		SPEEDOMETER		199 km/hr	
		TOTAL		LIGHT	HEAD LAMP		12V-55W/35W
		TOP SPEED			TAIL LAMP		13.5V-0.41W /12V-5W
	FUEL CONSUMPTION		BREAKING LAMP		13.5V-1.89W		
HILL CLIMB		TURNING LIGHT			13.5V-1.58W/13.5V-1.45W		
ENGINE	TYPE		HORN		DC 12V		
	FUEL		MUFFLER		C-D ABSORPTION		
	CYCLE/COOLING		4T/FORCE AIR&OIL COOL		IDLE EMISSION	PARTICLE	BELOW 15 %
	CYLINDER	BORE		CO		BELOW 3.0%	
		STROKE		HC		BELOW 1600 ppm	
		NUMBER		EXHAUST DIRECTION		RIGHT HAND SIDE & BACKWARD	
	DISPLACEMENT		LUBRICATION		COMPRESS & SPLASH		
	COMPRESSION RATIO		E. E. C.		NO		
	MAX POWER		P. C. V.		YES		
	MAX TORQUE		CATALYST		YES		
	ARRANGEMENT		S. A. I.		YES		
	IGNITION		STARTER		ELECTRIC		
REMARK	1. FUEL SUPPLY : INJECTION						

Information Summary and Preparation -1

1-2 Configuration

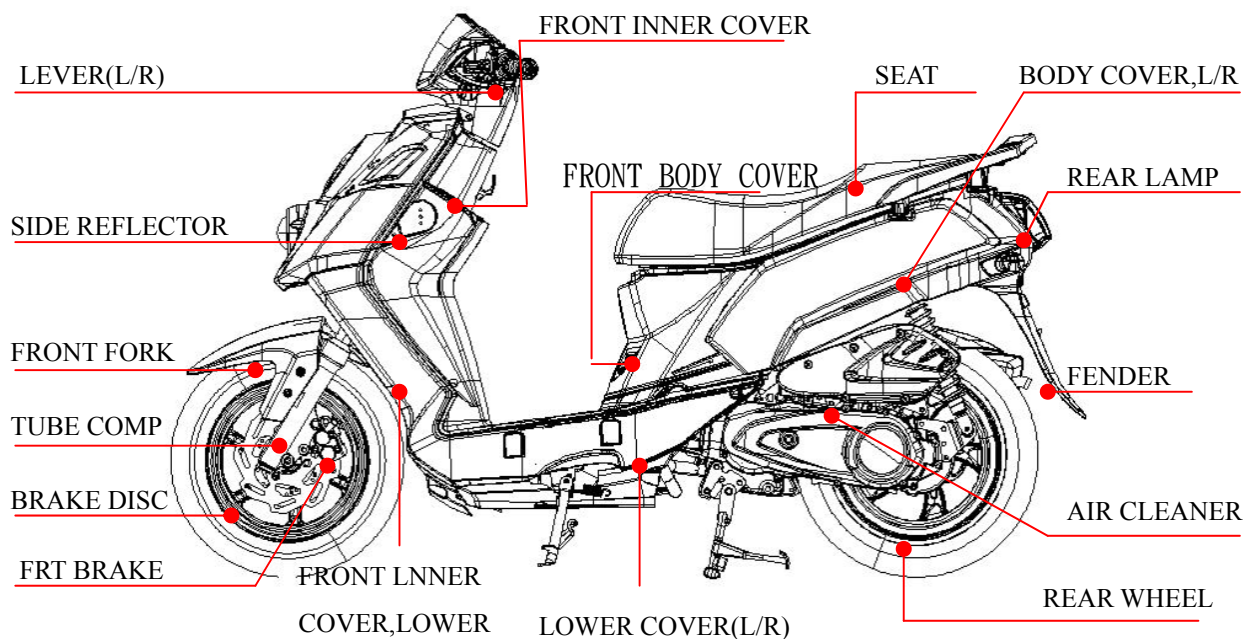
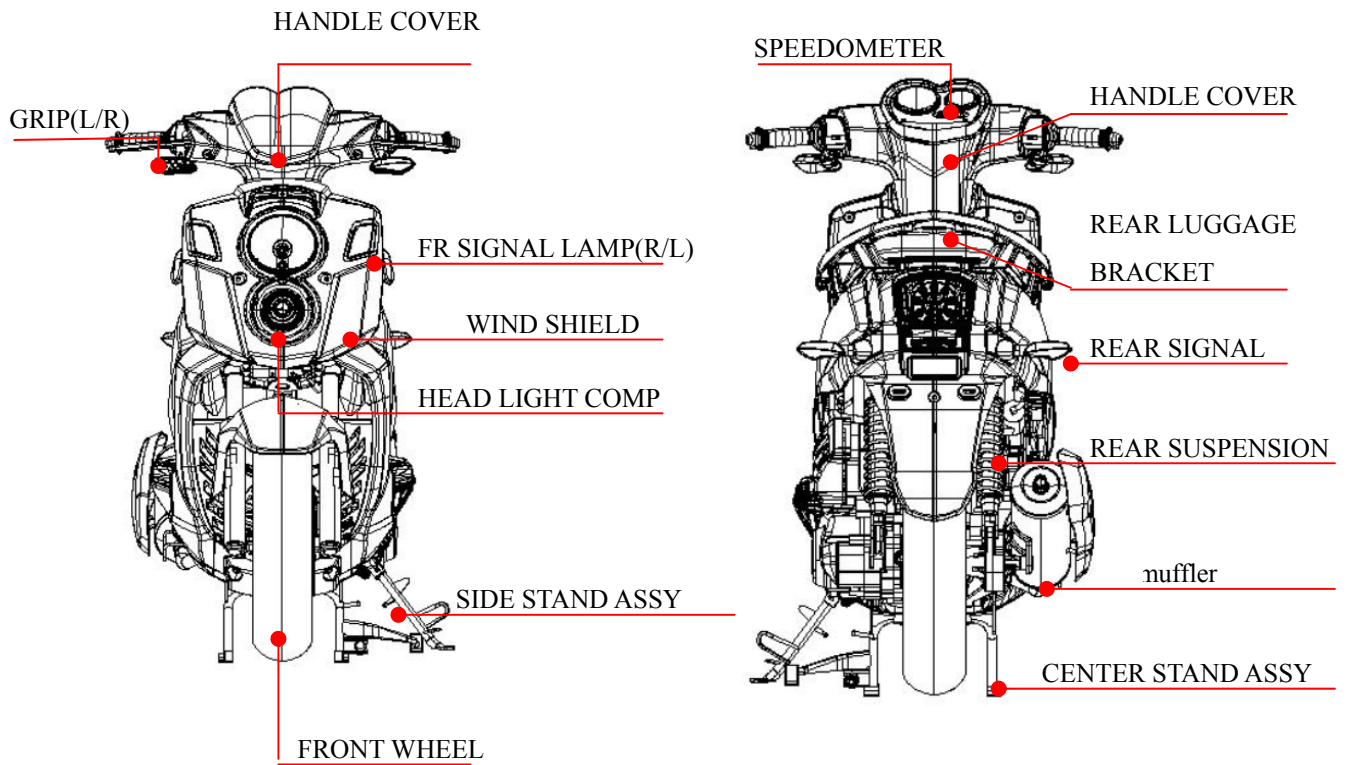

1-5 Code of practice:

1. Any clamp or cotter pin removed shall be replaced with a new one.
2. Any part to be replaced shall be manufactured by Motive Power.
3. Make sure of any assembled component securely fastened and formally activated.
4. Any bolts or nuts with large external diameters rather than small ones shall be screwed first and diagonally according to rated torque values as follows.
5. Any mechanic shall use specific or common tools for any disassembly and wear work shoes during maintenance.
6. The safety of any maintenance operation practiced by two mechanics shall be ensured each other.
7. Any electrical parts slightly heated with the motorcycle started are normal and not touched by hands directly.
8. Please keep any cable or wire harness to be installed properly fixed but not excessively tensioned or loosened without any acute (or sharp) angle or bulged bolt (or screw) piercing a cable. Check any cable or wire harness installed for any unnecessary twist or kink.
9. Do not put any tool on the motorcycle, particularly the battery unit to become a short circuit, during maintenance.
10. The battery in a motorcycle which has not been started for a long period shall be tested once to ensure its voltages and charged per month.
11. Please follow the correct steps to connect and disconnect a lead acid battery without the short circuit or inflammation.

1-5.1 Directions for maintenance of the Engine Management System (EMS)

1) Directions for General Maintenance

Any check to the Electronic Management System shall be made with a multi-meter only.

1. To make sure of the Electronic Management System properly running, please use parts supplied by Motive Power during maintenance.
2. Any operation to clean parts during maintenance shall be executed in a well-ventilated place.
3. Please follow the directions for steps of maintenance and diagnosis.
4. Do not disassemble or remove parts in the Electronic Management System during maintenance.
5. Please keep watch for any electronic element (electronic control unit, sensor, etc.) not fallen to the ground during maintenance; establish the environmental protection concept for any waste from maintenance invalidly disposed.

Information Summary and Preparation –1

2) Directions during maintenance

1. Do not arbitrarily remove any part or connector of the Electronic Management System from its initial position; avoid any accidental damage or foreign object such as water and greasy dirt to enter into any connector and affect a properly running Electronic Management System.
2. In order to prevent any electrical device from damage, the power supply shall be disconnected prior to a connector removed or connected.
3. During any operation to simulate the thermal state of one defective unit or increase temperatures, the temperature of the electronic control unit shall be less than 80 degrees Celsius.
4. All fuel hoses shall be high pressure-tolerant pipes in virtue of the high fuel pressure in the Electronic Management System (300kPa or so) or even at the engine stopped. As a result, the fuel hose during maintenance shall not be disassembled arbitrarily. In the case of maintaining the fuel system, the pressure in the fuel system shall be released prior to removal of a fuel hose shown as follows: Remove the fuel pump relay; start the engine; keep the engine at the idle speed until the engine stops. The operation of removal of a fuel hose and replacement of a clamp shall be executed by a professional mechanic in a well-ventilated place.
5. The power supplied to the electric fuel pump which is being removed from the fuel tank shall be disconnected beforehand to prevent any spark or fire.
6. The fuel pump to be tested shall not be empty or refilled by water or the service life will be curtailed. On the other hand, the positive and negative poles of the fuel pump shall be properly connected.
7. Unless otherwise required, the spark test shall not be conducted or be completed quickly during inspections of the ignition system. Additionally, the air throttle shall be kept closed during inspections or the incompletely ignited gasoline will be fed into the exhauster and damage the three-way catalytic converter.
8. The idle speed has been adjusted by the Electronic Management System in advance and not changed manually. The initial position of the throttle stop screw adjusted by Motive Power shall not be changed by a user without permission unless otherwise demanded.
9. The cables to be connected to the positive and negative poles on a battery shall be correctly linked or the electronic devices will be damaged. The **minus earth** is used in the system.
10. Any cable connected to a battery shall not be disconnected during the engine running.
11. The battery shall be removed from the motorcycle for a charge separately conducted but not be directly charged with the battery fixed on the vehicle for convenience.
12. The cables connected to the battery's positive & negative poles and the electronic control unit shall be removed from the motorcycle prior to any electrical welding operation.
13. Do not cut a cable's cover layer to test any signal imported to or exported from one device.

Information Summary and Preparation –1

1-6 Special tools

		
<p>1. Front fork - Bearing cage disassembly, tools</p>	<p>2. Brake oil-pumping unit</p>	<p>3. Bearing puller tool</p>
		
<p>4. Clutch compression tool</p>	<p>5. Fixator</p>	<p>6. feeler gauge</p>
		
<p>7. Bearing Striking Tools</p>	<p>8. Cylinder pressure gauge</p>	<p>9. Test line group</p>
		
<p>10. Hook type, wrench</p>	<p>11. RELEASING TOOL, FLYWHEEL MAGNETO</p>	<p>12. Crankshaft bearing removal tool</p>
		
<p>13. multimeter</p>	<p>14. Gasoline pressure gauge</p>	<p>15. Valve compression tool</p>

Information Summary and Preparation -1

		
<p>16. spark plug gap gauge</p>	<p>17.EMS diagnostics - dedicated</p>	<p>18. Hose clamp removal tool</p>
		
<p>19. Fuel injector cleaning tool</p>	<p>20. Oil seal removal tool - small</p>	<p>21. Dial gauge + Magnetic Base</p>
		
<p>22. Oil seal removal tool - Large</p>	<p>23. Fork oil seal into the tool</p>	

1-7 Trouble shooting

Procedure to maintain the Electronic Management System (EMS)

■ Systematic procedure to diagnose any troubles for reparation

Items to be checked first prior to any diagnoses for engine troubles:

1. Make sure of the engine trouble indicator normally running;
2. Check with a trouble diagnosis meter to ensure no trouble information recorded;
3. Check any trouble phenomenon hinted by the vehicle owner and trouble-related conditions.

External check:

- (1) Check any leakage from a fuel hose.
- (2) Check any leakage from a vacuum pipe.
- (3) Check any jam, leakage, flattening, or damage at an air inlet.
- (4) Check the ignition system for break or aging of any high-voltage cable and ignition status.
- (5) Check grounding of any wire harness clean and securely fixed.
- (6) Check any sensor or actuator's connector loosened or poorly contacted.

Note: Repair any trouble specified herein first which may affect the subsequent diagnoses or reparation.

■ Diagnosis assist:

1. Make sure of no engine-related trouble records;
2. Make sure of any offered troubles;
3. Follow the said procedure to complete inspections and find no any unconformable situation;
4. Do not ignore any effect from maintenance, cylinder pressure, mechanical timing, or fuel on the system;
5. Replace ECU for tests.

In the event of any trouble eliminated, ECU should be the source of trouble; if not, install the original ECU and repeat the procedure to recheck.

■ Trouble:

- Engine not running or slowly running during start-up
- Engine running but start-up failing during start-up
- Trouble of hot start
- Trouble of cold start
- Trouble of start-up anytime despite RPM normal
- Start-up normal but idle speed unstable anytime
- Start-up normal but idle speed unstable during warm-up
- Start-up normal but idle speed unstable with warm-up finished
- Start-up normal but idle speed unstable or stall with load such as front lamp applied
- Start-up normal but idle speed too high
- RPM low or stall during acceleration
- Acceleration slow
- Acceleration powerless; performance bad

Information Summary and Preparation –1

(1) Engine not running or slowly running during start-up

General trouble location: 1. Battery; 2. Start motor; 3. Main wiring or power switch; 4. Engine mechanism.

Procedure for general diagnoses:

No.	Operating Procedure	Detection Results	Subsequent Steps
1	Check the voltage between two battery terminals with a multi-meter to ensure the voltage between 11 and 12V during start-up of the engine.	Yes	Next step
		No	Replace the battery.
2	Keep the power switch “ON” and check the voltage at the positive terminal on the start motor over 8V.	Yes	Next step
		No	Fix or replace wiring harness.
3	Remove the start motor and check its status for open circuits or jam attributed to lubrication insufficient.	Yes	Fix or replace the start motor.
		No	Next step
4	For any trouble in winter only, check lubricant in the engine wrong for big resistance of the start motor.	Yes	Change applicable lubricant.
		No	Next step
5	Check the ECU circuit		

(2) Engine running but start-up failing during start-up

General trouble location: 1. Oil tank empty; 2. Fuel pump; 3. RPM sensor; 4. Ignition coils; 5. Engine mechanism.

Procedure for general diagnoses:

No.	Operating Procedure	Detection Results	Subsequent Steps
1	Connect a fuel pressure gauge before the fuel inlet of the nozzle; press the power switch repeatedly if necessary or start the engine to check the fuel pressure at 300kPa or so.	Yes	Next step
		No	Repair the fuel supply system.
2	Connect the EMS diagnosis tester and check “Engine RPM”; start the engine to check any RPM signal output .	Yes	Next step
		No	Correct circuits of the RMP sensor.
3	Disconnect the ignition cable and connect a spark tester; start the engine and check any high-voltage flash (blue/white).	Yes	Next step
		No	Repair the ignition system.
4	Check pressure of the engine cylinder and find any possibility of pressure insufficient.	Yes	Eliminate any mechanical trouble of the engine.
		No	Next step
5	Check the ECU circuit		

Information Summary and Preparation –1

(3) Trouble of hot start

General trouble location: 1. Water in fuel; 2. Fuel pump; 3. Engine temperature sensor; 4. Ignition coils

Procedure for general diagnoses:

No.	Operating Procedure	Detection Results	Subsequent Steps
1	Connect a fuel pressure gauge before the fuel inlet of the nozzle; start the engine to check the fuel pressure at 300kPa or so.	Yes	Next step
		No	Repair the fuel supply system.
2	Disconnect the ignition cable and connect a spark tester; start the engine and check any high-voltage flash (blue/white).	Yes	Next step
		No	Repair the ignition system.
3	Press the engine temperature sensor connector and start the engine; check if the engine successfully started. (Or <u>install a series-connected resistor (300Ω) in lieu of the engine temperature sensor at the engine temperature sensor connector.</u> Check if the engine is successfully started.)	Yes	Correct circuits or replace the sensor.
		No	Next step
		No	Next step
4	Check fuel and observe any trouble attributed to fuel just added.	Yes	Replace fuel.
		No	Next step
5	Check the ECU circuit		

Information Summary and Preparation –1

(4) Trouble of cold start

General trouble location: 1. Water in fuel; 2. Fuel pump; 3. Engine temperature sensor; 4. Nozzle; 5. Ignition coils; 6. Air throttle and & idle air bypass; 7. Engine mechanism.

Procedure for general diagnoses:

No.	Operating Procedure	Detection Results	Subsequent Steps
1	Connect a fuel pressure gauge before the fuel inlet of the nozzle; start the engine to check the fuel pressure at 300kPa or so.	Yes	Next step
		No	Repair the fuel system.
2	Disconnect the ignition cable and connect a spark tester; start the engine and check any high-voltage flash (blue/white).	Yes	Next step
		No	Repair the ignition system.
3	Press the engine temperature sensor connector and start the engine; check if the engine successfully started. (Or <u>install a series-connected resistor (2500Ω) in lieu of the engine temperature sensor at the engine temperature sensor connector.</u> Observe if the engine is successfully started.)	Yes	Correct circuits or replace any sensor.
		No	Next step
4	Slightly pull the throttle to check if the engine is easily started.	Yes	Clean the air throttle and the idle air bypass.
		No	Next step
5	Disassemble the nozzle and check any leakage or jam in the nozzle with a nozzle cleaner & analyzer.	Yes	Replace the defective nozzle.
		No	Next step
6	Check fuel and observe any trouble attributed to fuel just added.	Yes	Change fuel.
		No	Next step
7	Check pressure of the engine cylinder and find any possibility of pressure insufficient.	Yes	Eliminate any mechanical trouble of the engine.
		No	Next step
8	Check the ECU circuit		

Information Summary and Preparation –1

(5) Trouble of start-up anytime despite RPM normal

General trouble location: 1. Water in fuel; 2. Fuel pump; 3. Engine temperature sensor; 4. Nozzle; 5. Ignition coils; 6. Air throttle and & idle air bypass; 7. Air intake; 8. Ignition timing; 9. Spark plug; 10. Engine mechanism.

Procedure for general diagnoses:

No.	Operating Procedure	Detection Results	Subsequent Steps
1	Check any jam of the air filter and leakage of the air intake.	Yes	Repair the air intake system.
		No	Next step
2	Connect a fuel pressure gauge before the fuel inlet of the nozzle; start the engine to check the fuel pressure at 300kPa or so.	Yes	Next step
		No	Repair the fuel supply system.
3	Disconnect the ignition cable and connect a spark tester; start the engine and check any high-voltage flash (blue/white).	Yes	Next step
		No	Repair the ignition system.
4	Check the spark plug in the cylinder and its model and gap conformable to specifications.	Yes	Next step
		No	Adjust or change the spark plug.
5	Press the engine temperature sensor connector and start the engine; check if the engine is successfully started.	Yes	Correct circuits or replace the sensor.
		No	Next step
6	Slightly pull the throttle to check if the engine is easily started.	Yes	Clean the air throttle and the air intake for idle speed.
		No	Next step
7	Disassemble the nozzle and check any leakage or jam in the nozzle with a nozzle cleaner & analyzer.	Yes	Change the defective nozzle.
		No	Next step
8	Check fuel and observe any trouble attributed to fuel just added.	Yes	Change fuel.
		No	Next step
9	Check pressure of the engine cylinder and find any possibility of pressure insufficient.	Yes	Eliminate any mechanical trouble of the engine.
		No	Next step
10	Check if mechanical ignition timing of the engine is conformable to specifications.	Yes	Next step
		No	Correct ignition timing.
11	Check the ECU circuit		

Information Summary and Preparation –1

(6) Start-up normal but idle speed unstable anytime

General trouble location: 1. Water in fuel; 2. Nozzle; 3. Spark plug; 4. Air throttle and idle air bypass; 5. Air intake; 6. ISC; 7. Ignition timing; 8. Spark plug; 9. Engine mechanism.

Procedure for general diagnoses:

No.	Operating Procedure	Detection Results	Subsequent Steps
1	Check any jam of the air filter and leakage of the air intake.	Yes	Repair the air intake system.
		No	Next step
2	Check the Idle governor for the control valve jammed.	Yes	Change
		No	Next step
3	Check the spark plug and its model and gap conformable to specifications.	Yes	Next step
		No	Adjustment or change
4	Check the air throttle and the idle air bypass for any carbon deposition.	Yes	Cleaning
		No	Next step
5	Disassemble the nozzle and check any leakage or jam in the nozzle with a nozzle cleaner & analyzer.	Yes	Replace the defective nozzle.
		No	Next step
6	Check fuel and observe any trouble attributed to fuel just added.	Yes	Change fuel.
		No	Next step
7	Check pressure of the engine cylinder and find any big difference in pressure.	Yes	Eliminate any mechanical trouble of the engine.
		No	Next step
8	Check if mechanical ignition timing of the engine is conformable to specifications.	Yes	Next step
		No	Correct ignition timing.
9	Check the ECU circuit		

Information Summary and Preparation –1

(7) Start-up normal but idle speed unstable during warm-up

General trouble location: 1. Water in fuel; 2. Engine temperature sensor; 3. Spark plug; 4. Air throttle and idle air bypass; 5. Air intake; 6. Idle governor; 7. Engine mechanism.

Procedure for general diagnoses:

No.	Operating Procedure	Detection Results	Subsequent Steps
1	Check any jam of the air filter and leakage of the air intake.	Yes	Repair the air intake system.
		No	Next step
2	Check the spark plug and its model and gap conformable to specifications.	Yes	Next step
		No	Adjustment or change
3	Remove the Idle governor and check the air throttle, the isc, and the idle air bypass for any carbon deposition.	Yes	Clean relevant parts.
		No	Next step
4	Press the engine temperature sensor connector and start the engine to check any instability of the idle speed during warm-up of the engine.	Yes	Correct circuits or replace any sensor.
		No	Next step
5	Disassemble the nozzle and check the nozzle leaking or blocked, or the flow out of tolerance with a nozzle cleaner & analyzer.	Yes	Change the defective nozzle.
		No	Next step
6	Check fuel and observe any trouble attributed to fuel just added.	Yes	Change fuel.
		No	Next step
7	Check pressure of the engine cylinder and find any big difference in pressure.	Yes	Eliminate any mechanical trouble of the engine.
		No	Next step
8	Check the ECU circuit		

Information Summary and Preparation –1

(8) Start-up normal but idle speed unstable with warm-up finished

General trouble location: 1. Water in fuel; 2. Engine temperature sensor; 3. Spark plug; 4. Air throttle and idle air bypass; 5. Air intake; 6. ISC; 7. Engine mechanism.

Procedure for general diagnoses:

No.	Operating Procedure	Detection Results	Subsequent Steps
1	Check any jam of the air filter and leakage of the air intake.	Yes	Repair the air intake system.
		No	Next step
2	Check the spark plug and its model and gap conformable to specifications.	Yes	Next step
		No	Adjustment or change
3	Remove the ISC and check the air throttle, the ISC and the idle air bypass for any carbon deposition.	Yes	Clean relevant parts.
		No	Next step
4	Press the engine temperature sensor connector and start the engine to check any instability of the idle speed during warm-up of the engine.	Yes	Correct circuits or replace any sensor.
		No	Next step
5	Disassemble the nozzle and check the nozzle leaking or blocked, or the flow out of tolerance with a nozzle cleaner & analyzer.	Yes	Change the defective nozzle.
		No	Next step
6	Check fuel and observe any trouble attributed to fuel just added.	Yes	Change fuel.
		No	Next step
7	Check pressure of the engine cylinder and find any big difference in pressure.	Yes	Eliminate any mechanical trouble of the engine.
		No	Next step
8	Check the ECU circuit		

Information Summary and Preparation –1

(9) Start-up normal but idle speed unstable or stall with load such as front lamp applied

General trouble location: 1. ISC 2. Nozzle.

Procedure for general diagnoses:

No.	Operating Procedure	Detection Results	Subsequent Steps
1	Remove the ISC and check the air throttle, the ISC and the idle air bypass for any carbon deposition.	Yes	Clean relevant parts.
		No	Next step
2	Check if the engine's output power is increased with the load applied; use the EMS diagnosis tester to check any change in the ignition advance angle, duration of fuel injection, and air input.	Yes	Go to Step 4.
		No	Next step
		No	Repair the air regulating system.
3	Disassemble the nozzle and check the nozzle leaking or blocked, or the flow out of tolerance with a nozzle cleaner & analyzer.	Yes	Change the defective nozzle.
		No	Next step
4	Check the ECU circuit		

(10) Start-up normal but idle speed too high

General trouble location: 1. Air throttle and idle air bypass; 2. Vacuum tube; 3, ISC ; 4. Engine temperature sensor; 5. Ignition timing.

Procedure for general diagnoses:

No.	Operating Procedure	Detection Results	Subsequent Steps
1	Check the throttle cable for jammed or too tight.	Yes	Adjustment
		No	Next step
2	Check the air intake system and the connected vacuum tube for any leakage.	Yes	Repair the air intake system.
		No	Next step
3	Remove the ISC and check the air throttle, the ISC and the idle air bypass for any carbon deposition.	Yes	Clean relevant parts.
		No	Next step
4	Press the engine temperature sensor connector and start the engine; check if the engine's the idle speed is too high.	Yes	Correct circuits or replace any sensor.
		No	Next step
5	Check if mechanical ignition timing of the engine is conformable to specifications.	Yes	Next step
		No	Correct ignition timing.
6	Check the ECU circuit		

Information Summary and Preparation –1

(11) RPM low or stall during acceleration

General trouble location: 1. Water in fuel; 2. Inlet pressure sensor & air throttle sensor; 3, Spark plug; 4. Air throttle & idle air bypass; 5. Air intake; 6.ISC ; 7. Nozzle; 8. Ignition timing; 9. Exhauster.

Procedure for general diagnoses:

No.	Operating Procedure	Detection Results	Subsequent Steps
1	Check the air filter for any jam.	Yes	Check the air intake system.
		No	Next step
2	Connect a fuel pressure gauge before the fuel inlet of the nozzle; start the engine to check the fuel pressure at 300kPa or so during the idle status.	Yes	Next step
		No	Repair the fuel supply system.
3	Check the spark plug in the cylinder and its model and gap conformable to specifications.	Yes	Next step
		No	Adjustment or replacement
4	Remove the ISC and check the air throttle, the ISC and the idle air bypass for any carbon deposition.	Yes	Clean relevant parts.
		No	Next step
5	Check the inlet pressure sensor, the air throttle and circuits.	Yes	Next step
		No	Correct circuits or replace any sensor.
6	Disassemble the nozzle and check any leakage or jam in the nozzle with a nozzle cleaner & analyzer.	Yes	Replace the defective nozzle.
		No	Next step
7	Check fuel and observe any trouble attributed to fuel just added.	Yes	Change fuel.
		No	Next step
8	Check if ignition timing of the engine is conformable to specifications.	Yes	Next step
		No	Correct ignition timing.
9	Check the exhauster for exhaust normally discharged.	Yes	Next step
		No	Repair or replace the exhauster.
10	Check the ECU circuit		

Information Summary and Preparation –1

(12) Acceleration slow

General trouble location: 1. Water in fuel; 2. Inlet pressure sensor and air throttle sensor; 3. Spark plug; 4. Air throttle and idle air bypass; 5. Air intake; 6. ISC ; 7. Nozzle; 8. Ignition timing; 9. Exhauster.

Procedure for general diagnoses:

No.	Operating Procedure	Detection Results	Subsequent Steps
1	Check the air filter for any jam.	Yes	Check the air intake system.
		No	Next step
2	Connect a fuel pressure gauge before the fuel inlet of the nozzle; start the engine to check the fuel pressure at 300kPa or so during the idle status.	Yes	Next step
		No	Repair the fuel supply system.
3	Check the spark plug in the cylinder and its model and gap conformable to specifications.	Yes	Next step
		No	Adjustment or replacement
4	Remove the ISC and check the air throttle, the ISC and the idle air bypass for any carbon deposition.	Yes	Clean relevant parts.
		No	Next step
5	Check the inlet pressure sensor, the air throttle sensor and circuits.	Yes	Next step
		No	Correct circuits or replace any sensor.
6	Disassemble the nozzle and check any leakage or jam in the nozzle with a nozzle cleaner & analyzer.	Yes	Replace the defective nozzle.
		No	Next step
7	Check fuel and observe any trouble attributed to fuel just added.	Yes	Change fuel.
		No	Next step
8	Check if the engine's ignition timing is conformable to specifications.	Yes	Next step
		No	Correct ignition timing.
9	Check the exhauster for exhaust normally discharged.	Yes	Next step
		No	Repair or replace the exhauster.
10	Check the ECU circuit		

Information Summary and Preparation –1

(13) Acceleration powerless; performance bad

General trouble location: 1. Water in fuel; 2. Inlet pressure sensor and air throttle sensor; 3. Spark plug; 4. Ignition coils; 5. Air throttle and idle air bypass; 6. Air intake; 7. ISC ; 8. Nozzle; 9. Ignition timing; 10. Exhauster.

Procedure for general diagnoses:

No.	Operating Procedure	Detection Results	Subsequent Steps
1	Check any troubles such as clutch slip, low tire pressure, brake drag, wrong tire size.	Yes	Reparation
		No	Next step
2	Check the air filter for any jam.	Yes	Repair the air intake system.
		No	Next step
3	Connect a fuel pressure gauge before the fuel inlet of the nozzle; start the engine to check the fuel pressure at 300kPa or so during the idle status.	Yes	Next step
		No	Repair the fuel supply system.
4	Disconnect the ignition cable and connect a spark tester; start the engine and check any high-voltage flash (blue/white).	Yes	Next step
		No	Repair the ignition system.
5	Check the spark plug in the cylinder and its model and gap conformable to specifications.	Yes	Next step
		No	Adjustment or replacement
6	Remove the ISC and check the air throttle, the ISC and the idle air bypass for any carbon deposition.	Yes	Clean relevant parts.
		No	Next step
7	Check the inlet pressure sensor, the air throttle sensor and circuits.	Yes	Next step
		No	Correct circuits or replace any sensor.
8	Disassemble the nozzle and check any leakage or jam in the nozzle with a nozzle cleaner & analyzer.	Yes	Replace the defective nozzle.
		No	Next step
9	Check fuel and observe any trouble attributed to fuel just added.	Yes	Change fuel.
		No	Next step
10	Check if the engine's ignition timing is conformable to specifications.	Yes	Next step
		No	Correct ignition timing.
11	Check the exhauster for exhaust normally discharged.	Yes	Next step
		No	Repair or replace the exhauster.
12	Check the ECU circuit		

Relations of plastic parts

* inclined parts could be dismantle directly

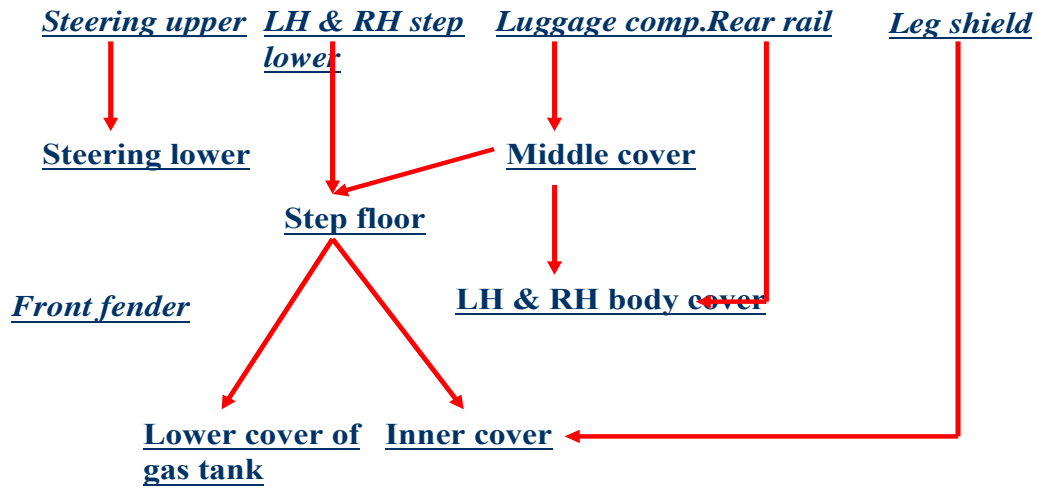

➤ Dismantle Bottom cover of luggage comp/ Dismantle battery cover

A.Bottom cover

* dismantle-

- 1 .Remove the bolts (15), the Bottom cover (6) launched in the direction of the arrow and remove the.

* install-

According to the reverse procedure as above.

B.battery cover

* dismantle-

Hand turn the screw (13), take out the battery cover(7).

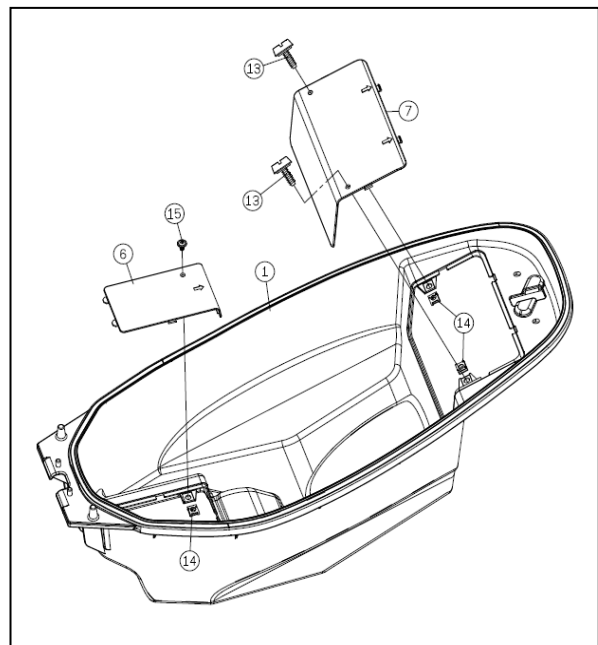

* install-

According to the reverse procedure as above.

➤ Luggage compartment

* dismantle-

1. open seat.
2. Remove the bolts (2) , take out the luggage compartment(1).

* install-

According to the reverse procedure as above.

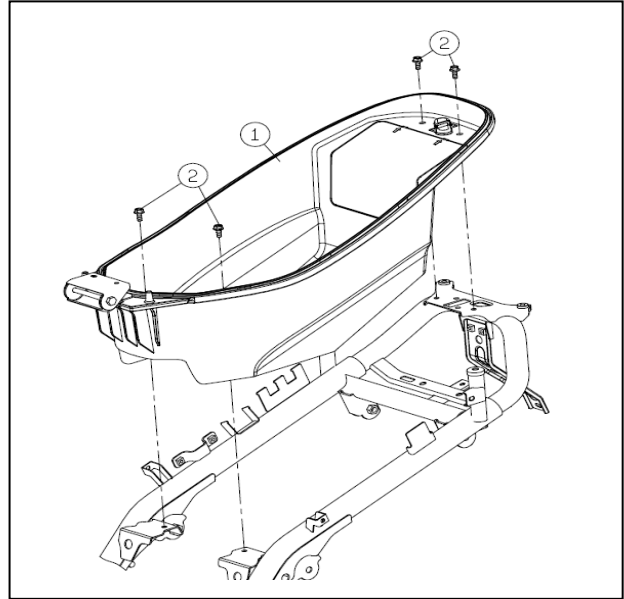

➤ Rear rack

* dismantle-

1. Remove the bolts/ Washer(7/8) , Take out the rear rack(6).

* install-

According to the reverse procedure as above.

Attention! lock bolts evenly
Torque: 2.5~3.0kg-m

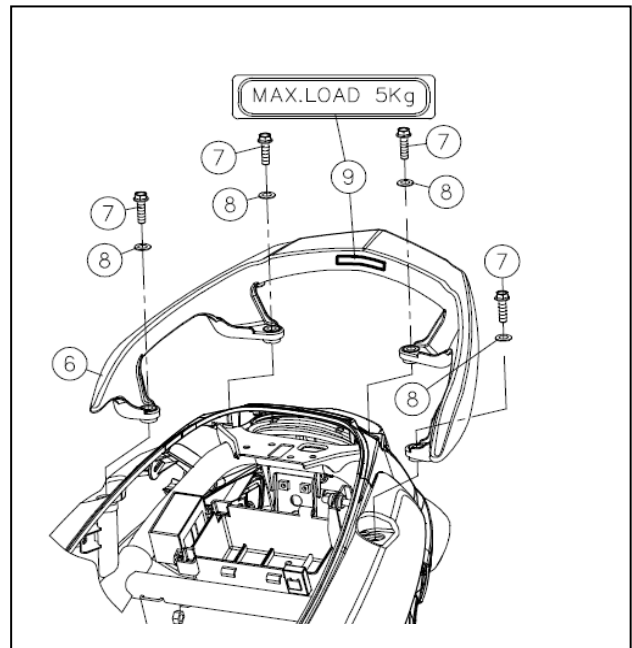

➤ Dismantle middle cover

* dismantle-

1. Remove the bolts(5) , take out the middle cover (4).

* install-

According to the reverse procedure as above.

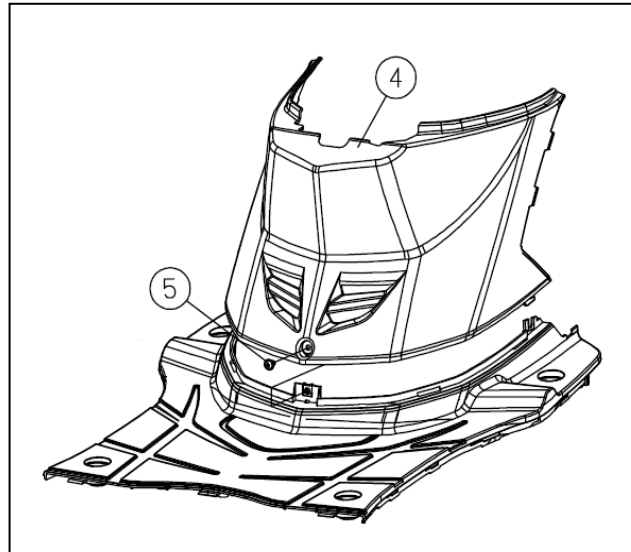

➤ Body cover

* dismantle-

1. Remove the screws(2)- Figure 1.
- 2.Remove the screws(3)- Figure 2.
3. Remove the signal lamp socket- Figure 3.

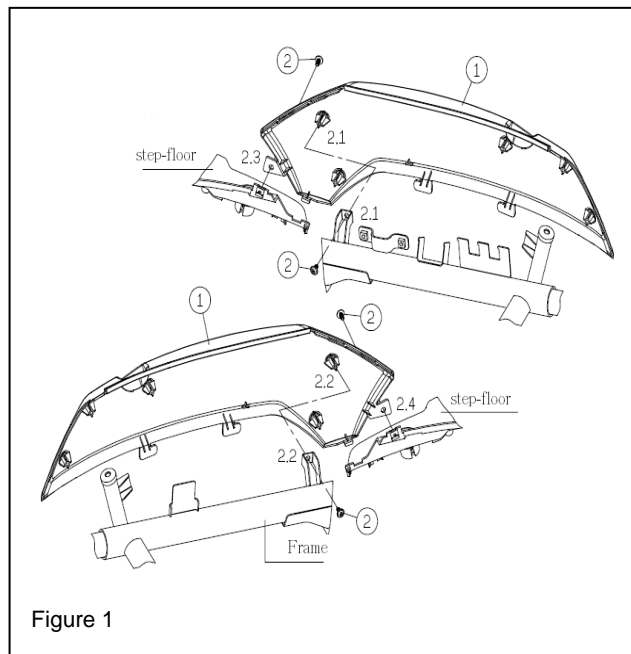

Figure 1

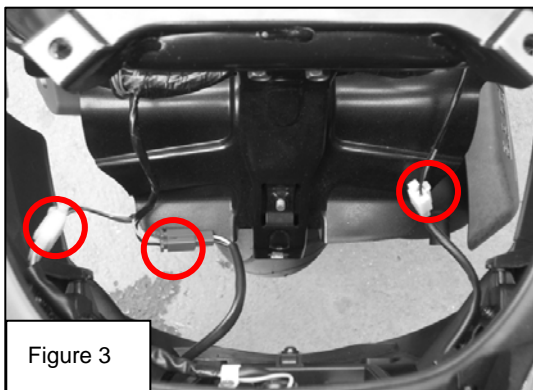

Figure 3

* install-

According to the reverse procedure as above.

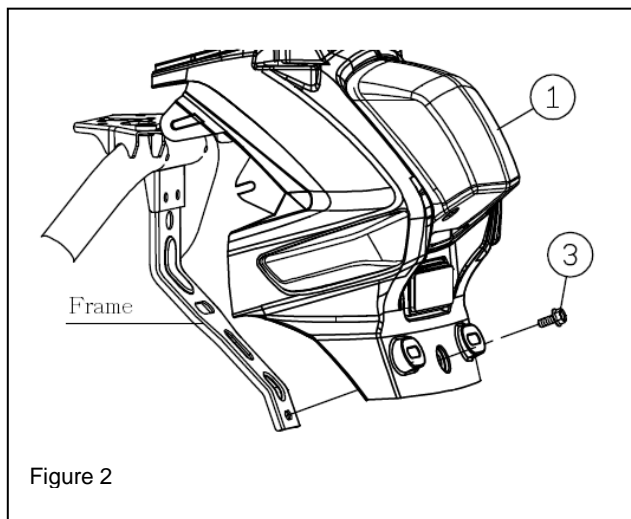

Figure 2

Installation or Removal of External Components- 2

Single decomposition: Left / Right Body Cover

* dismantle-

1. Remove the self-tapping screws (6), separation the rear lamp (1) with the left / right body cover (5/4).
2. Separate left / right body cover and the left / right cover (2/3).

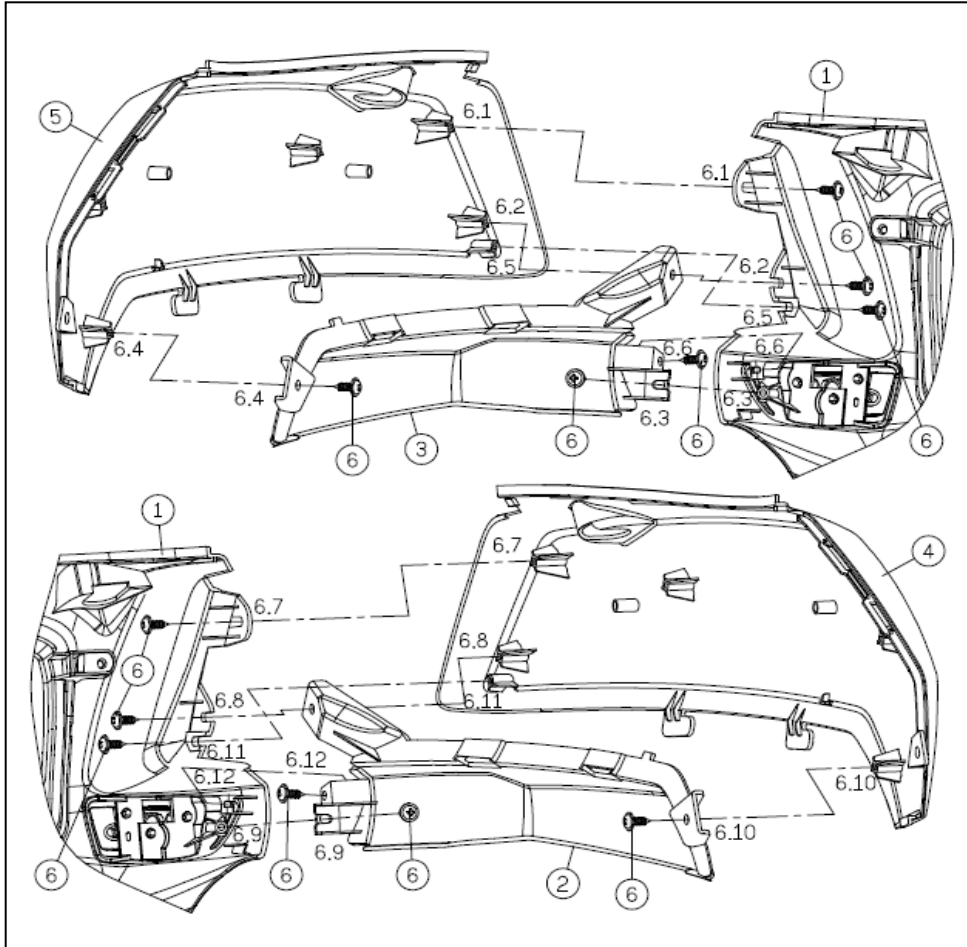

* install-

According to the reverse procedure as above.

Single decomposition: license plate

* dismantle-

1. Remove the self-tapping screws(12) · take out the license plate (11).

* install-

According to the reverse procedure as above.

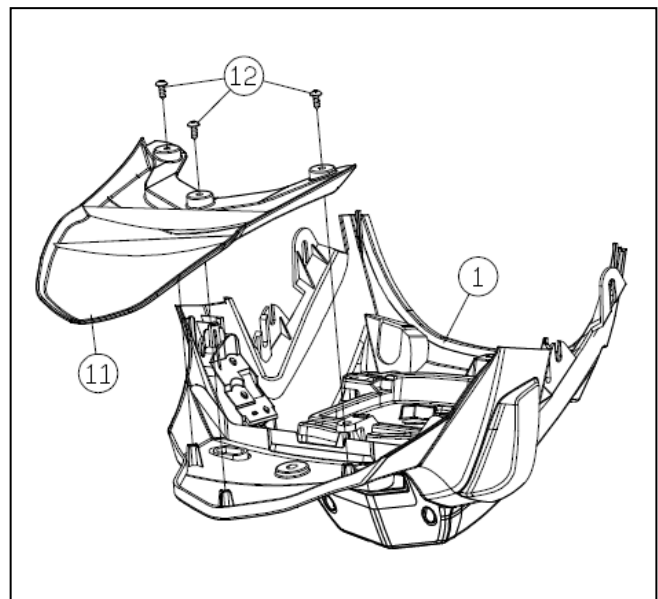

Single decomposition: Rear lamp (9) and the license plate (1) Combination

* dismantle-

1. Remove the self-tapping screws (10), separation rear lamp (9).
2. Remove the self-tapping screws (6/8), separating left / right signal lamp(5/7).
3. Remove the nut / washer (3/4), separated Reflectors(2).

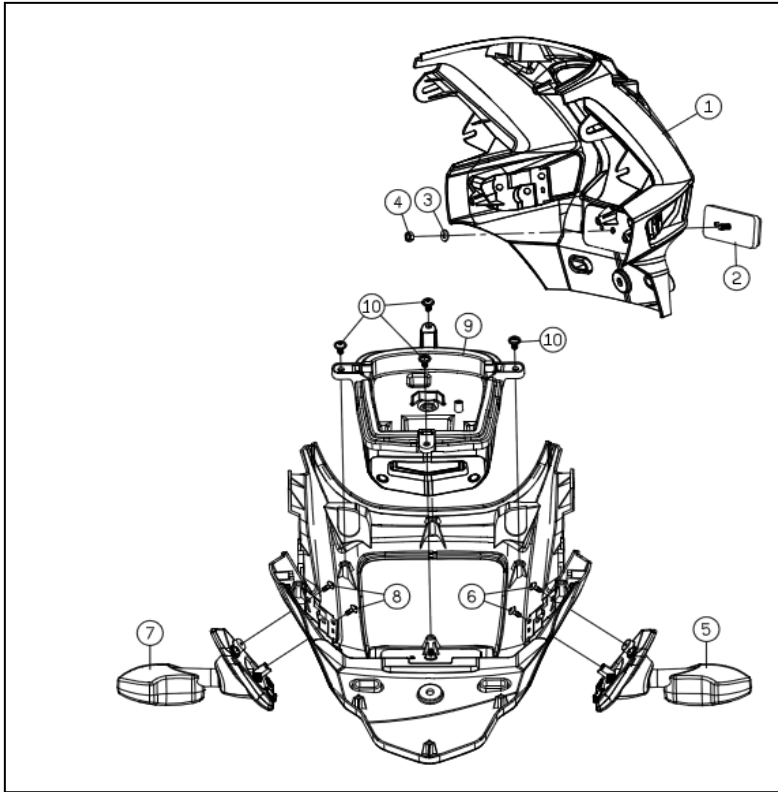

* install-

According to the reverse procedure as above.

Single decomposition: Reflector holder

* dismantle-

1. Remove the screws/washer(5/6/7) , take out the Reflector holder.
2. Remove the screws(4) , take out the reflector DOT(2).

* install-

According to the reverse procedure as above.

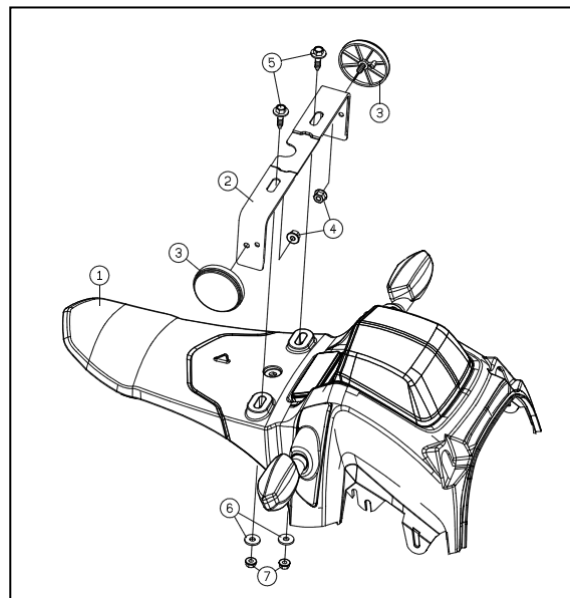

Installation or Removal of External Components- 2

➤ **Battery box**

* dismantle-

1. Remove the screws(11) , take out the fuse box.
2. Remove the screws(10) , take out the Battery box(9).

* install-

According to the reverse procedure as above.

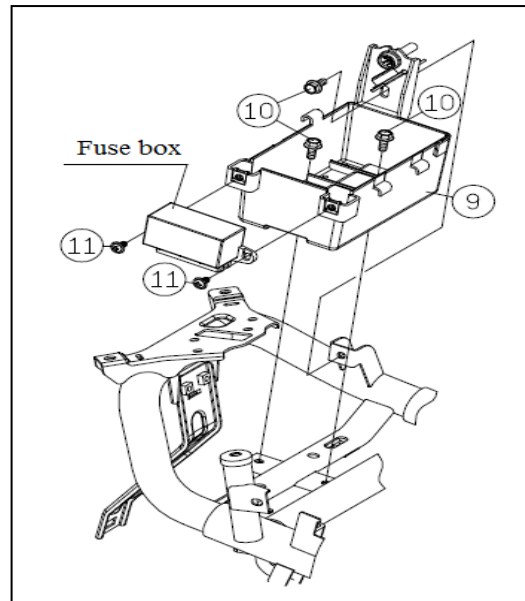

Single decomposition:

* dismantle-

1. Remove the screws , take out the diagnose adaptor(2).
2. Remove the rubber plug (4) .
3. Remove the U type spring nut (2).

* install-

According to the reverse procedure as above.

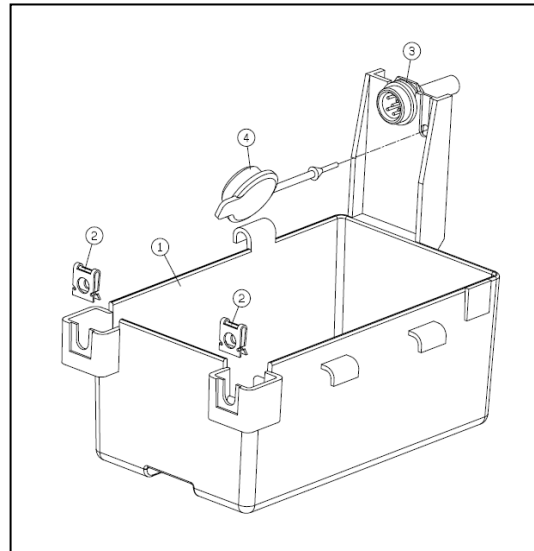

➤ **Body cover-lower**

* dismantle-

1. Remove the screws(13) , take out the Body cover-lower (16).

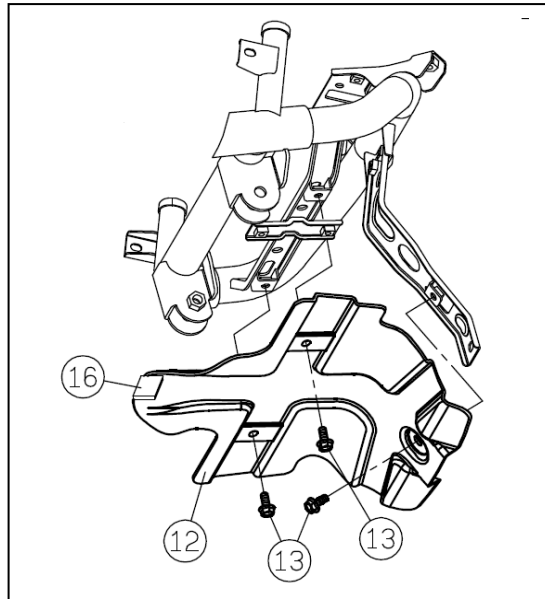

* install-

According to the reverse procedure as above.

➤ **Cushion**

* dismantle-

1. Remove the wire clip , take out the Cushion.

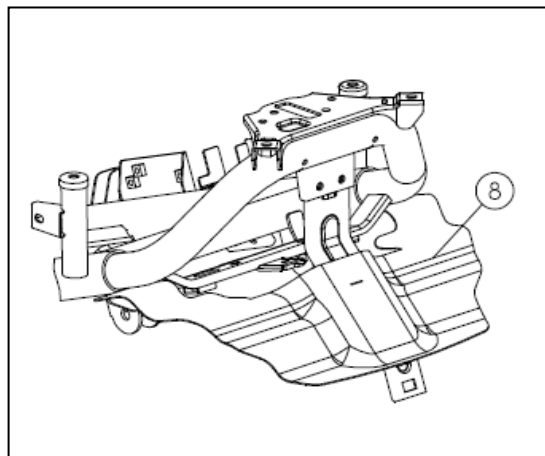

* install-

According to the reverse procedure as above.

➤ **Licence plate link plate**

* dismantle-

1. Remove the screws(7) , take out the Licence plate link plate(6).

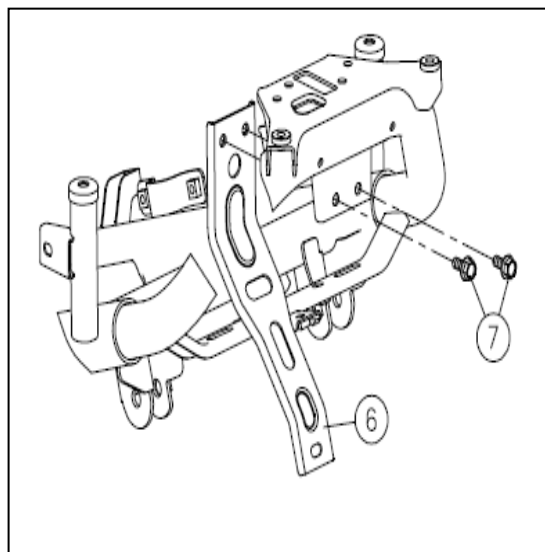

* install-

According to the reverse procedure as above.

➤ Dismantle the upper cover

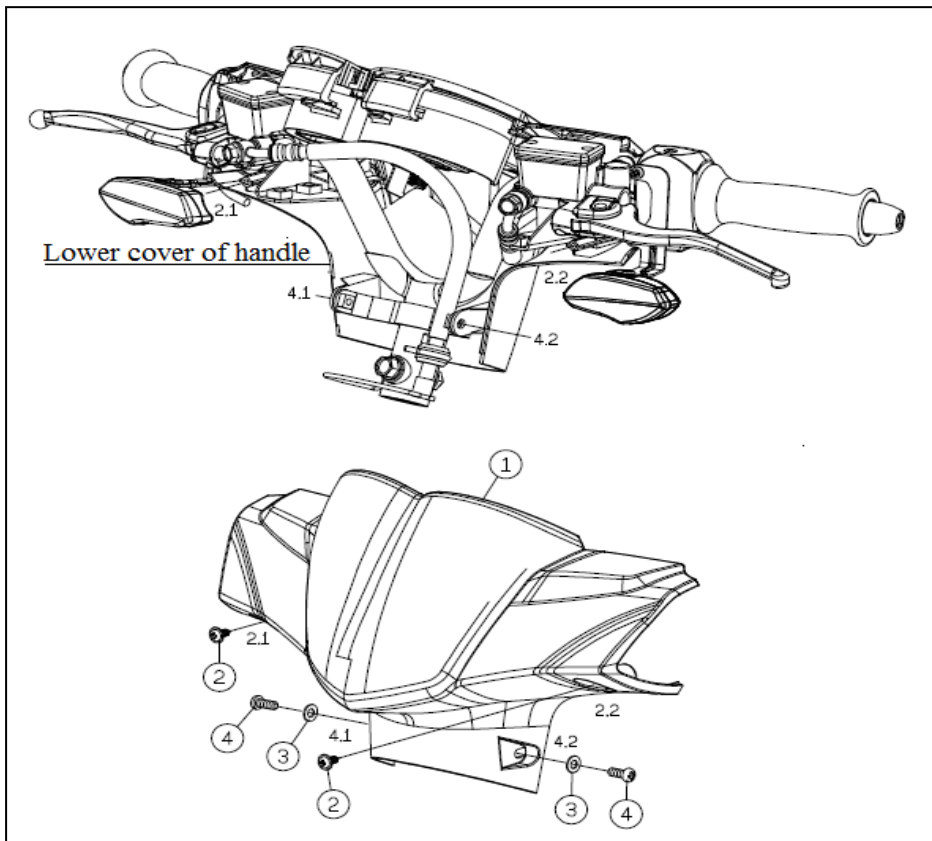

* dismantle-

1.Remove the screws(2/3/4) , take out the upper cover (1).

* install-

According to the reverse procedure as above.

➤ The lower cover of handle

* dismantle-

1.Remove the screws(3) , take out the lower cover of handle(2).

2.loosen speedometer cable.

* install-

According to the reverse procedure as above.

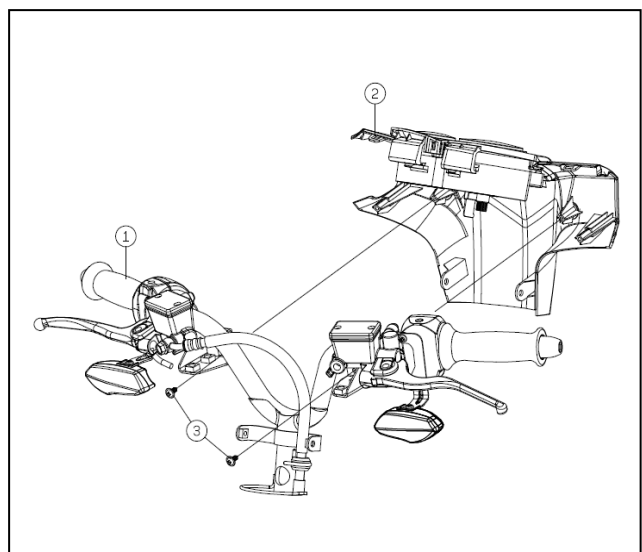

Installation or Removal of External Components- 2

➤ speedometer /speedometer cover

* dismantle-

- 1.Remove the screws(5/6) , take out the speedometer(1).
- 2.Remove the screws(3) , take out the speedometer cover(2).

* install-

According to the reverse procedure as above.

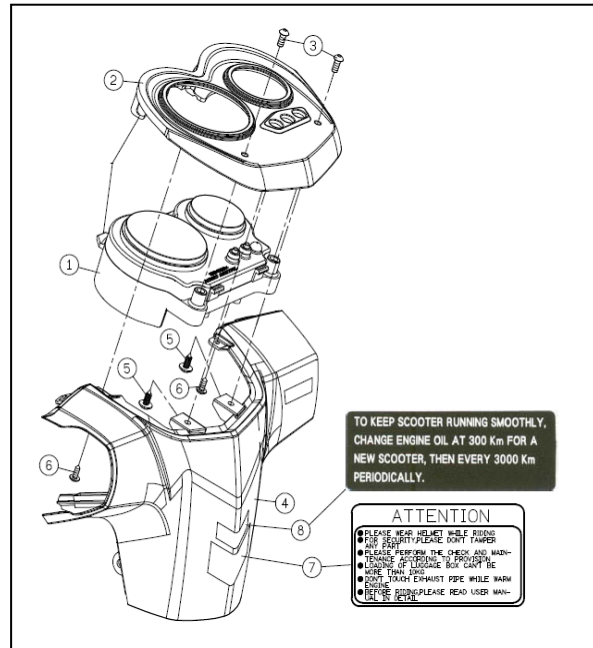

Installation or Removal of External Components- 2

➤ Brake master cylinder / Haft switch assy disassembly

* dismantle Step-

1. The brake fluid extraction was complete, remove the joint bolt (11) and copper gasket(10), remove the brake master cylinder (6/8) screws and take out the brake master cylinder(6/8)- Figure (1.2).
2. Remove the bolts (4) and right haft switch fixing screws (7),take out the grip(9) 、 haft switch(2) and front right signallamp (6)- Figure 1.
3. Remove left haft switch fixing screws (4),take out the haft switch(2) and front left signallamp (3)- Figure 2.

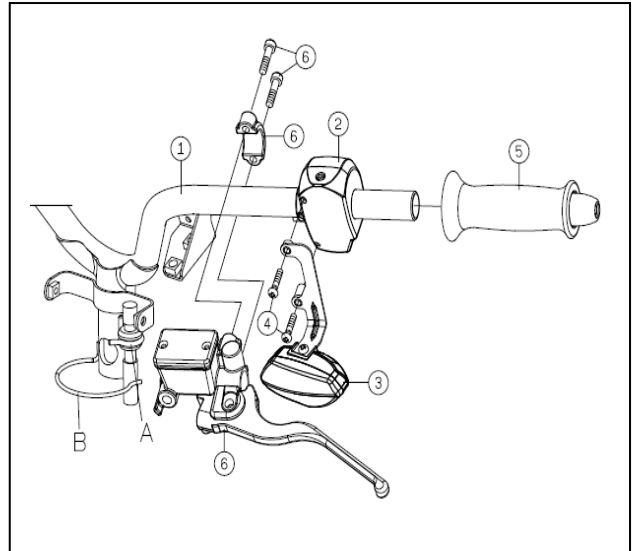
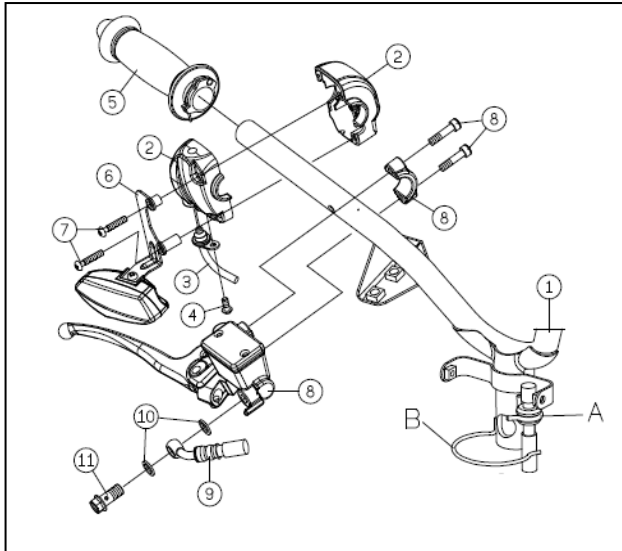

4. Installation, the brake master cylinder aligned with mark on the handle bar (shown right).

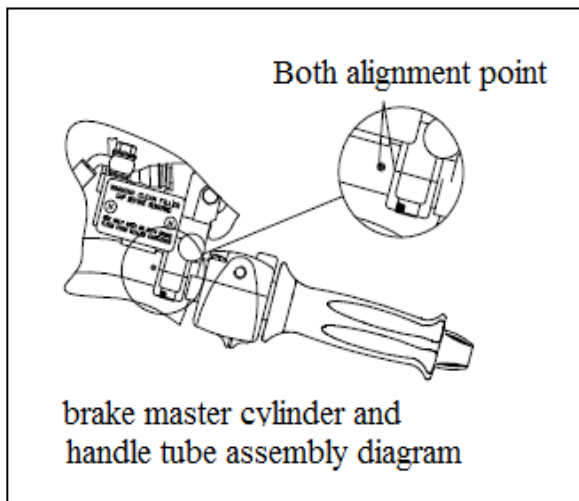

Installation or Removal of External Components- 2

5. Install the brake hose, place the hose fixed at A.

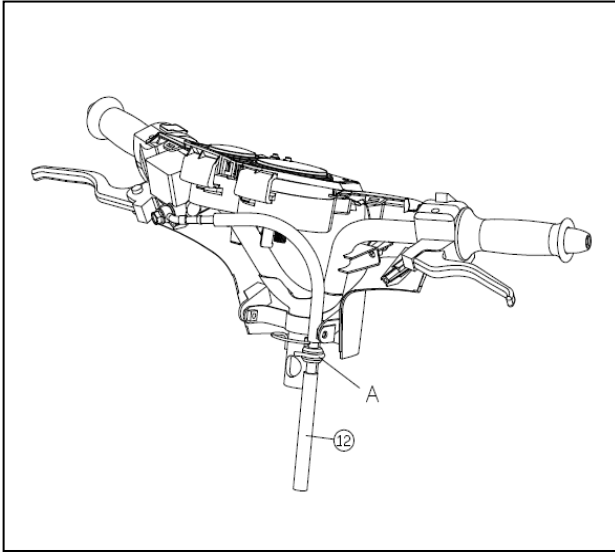

* install-

According to the reverse procedure as above.

➤ front signallamp

* dismantle-

1. Remove the screws(3), take out the fixed plate(1).

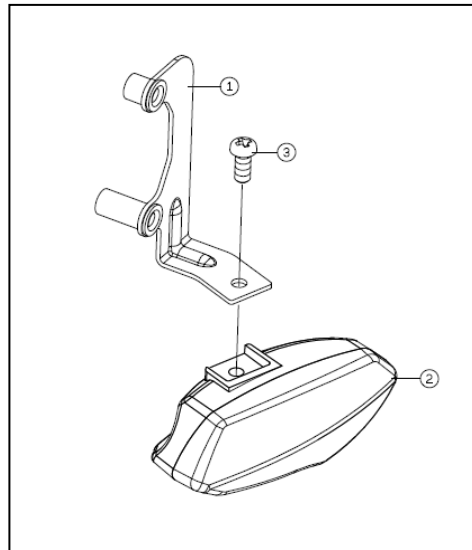
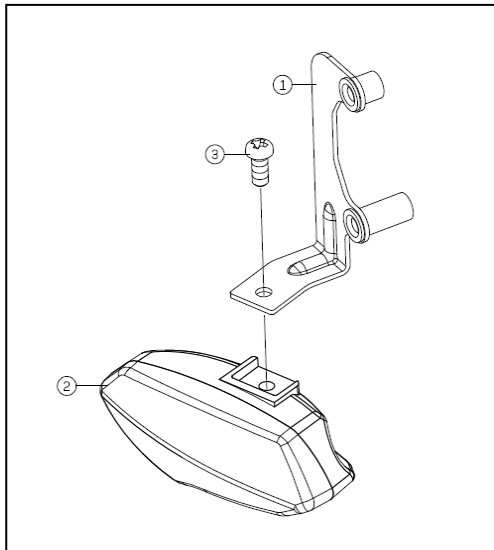

* install-

According to the reverse procedure as above.

➤ Dismantle Windshield

* dismantle-

1. Remove the screws(2)- Figure 1.
2. Remove the screws(3)- Figure 2.

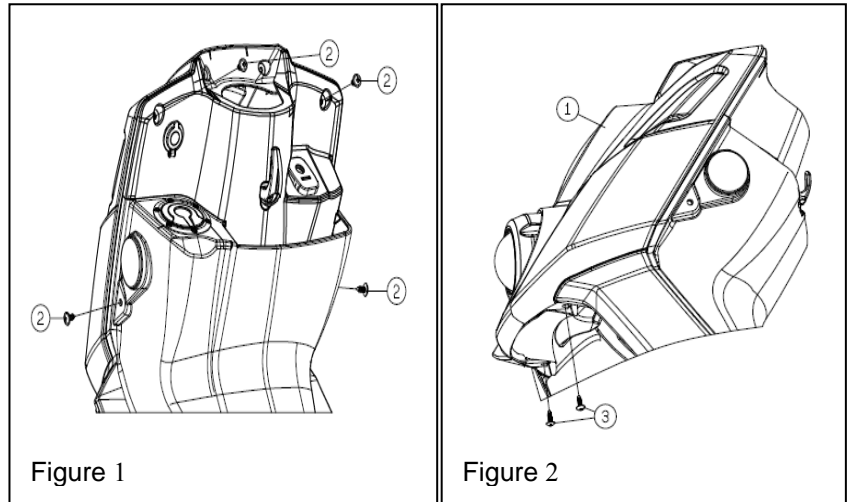

3. Remove the screws(4/5/6/7) , take out the Windshield(1)- Figure 3.

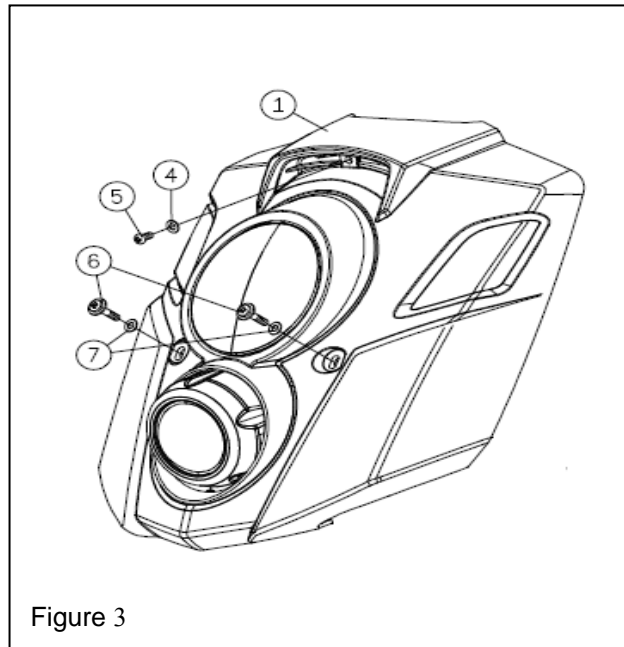

Parts 2: U TYPE SPRING NUT

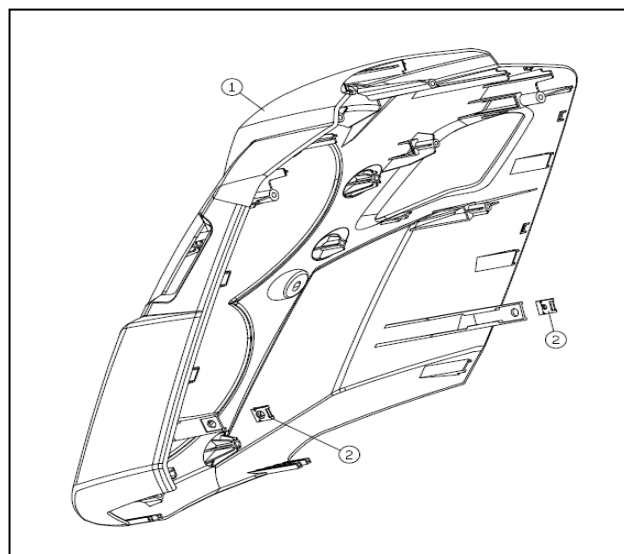

Installation or Removal of External Components- 2

Single decomposition: turn signal front

* dismantle-

- 1.Remove the screws(3/5) , take out the turn signal (2/4).

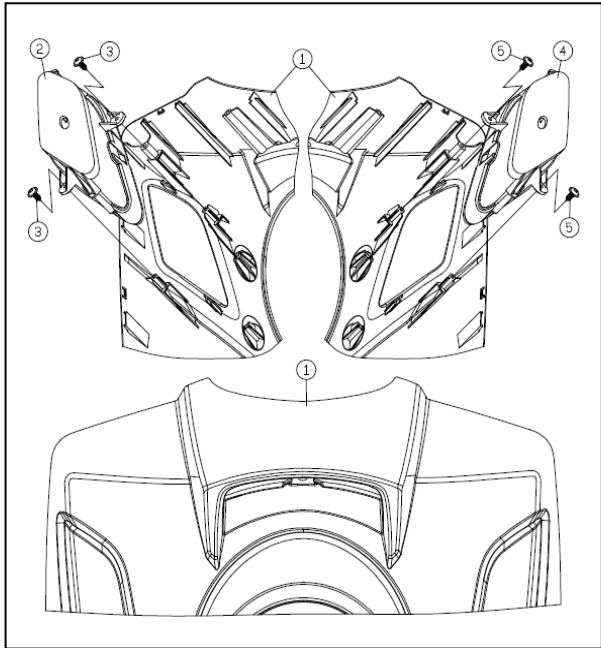

* install-

According to the reverse procedure as above.

Single decomposition:

* dismantle-

- 1.Remove the screws (5) , take out the head light (4).
- 2.Remove the screws (3) , take out the headlamp ornament frame (2).
- 3.Remove the screws (7) , take out the front Inner cover (6).

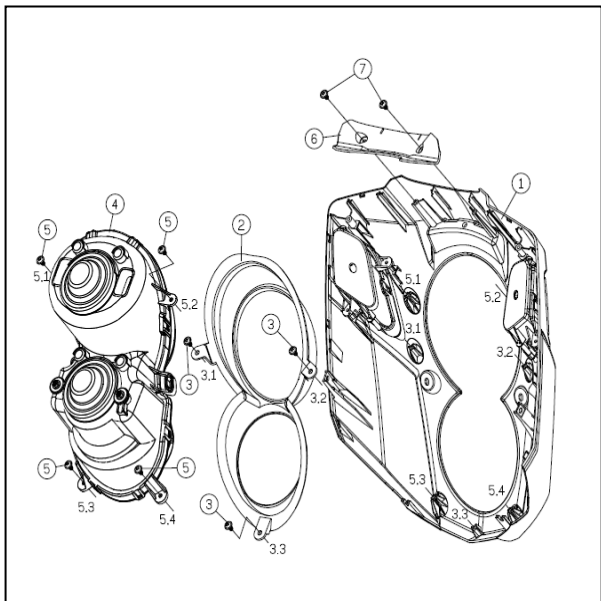

* install-

According to the reverse procedure as above.

Installation or Removal of External Components- 2

➤ Dismantle front fender

* dismantle-

1. Remove the screws(13/14) , take out the front fender(12) 、 speedmeter cable clip comp (11/16).

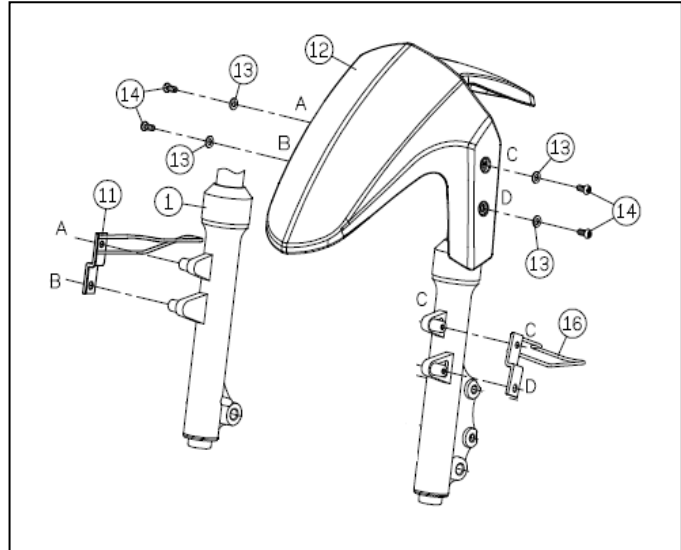

* install-

According to the reverse procedure as above.

➤ Dismantle Foot step floor lower cover

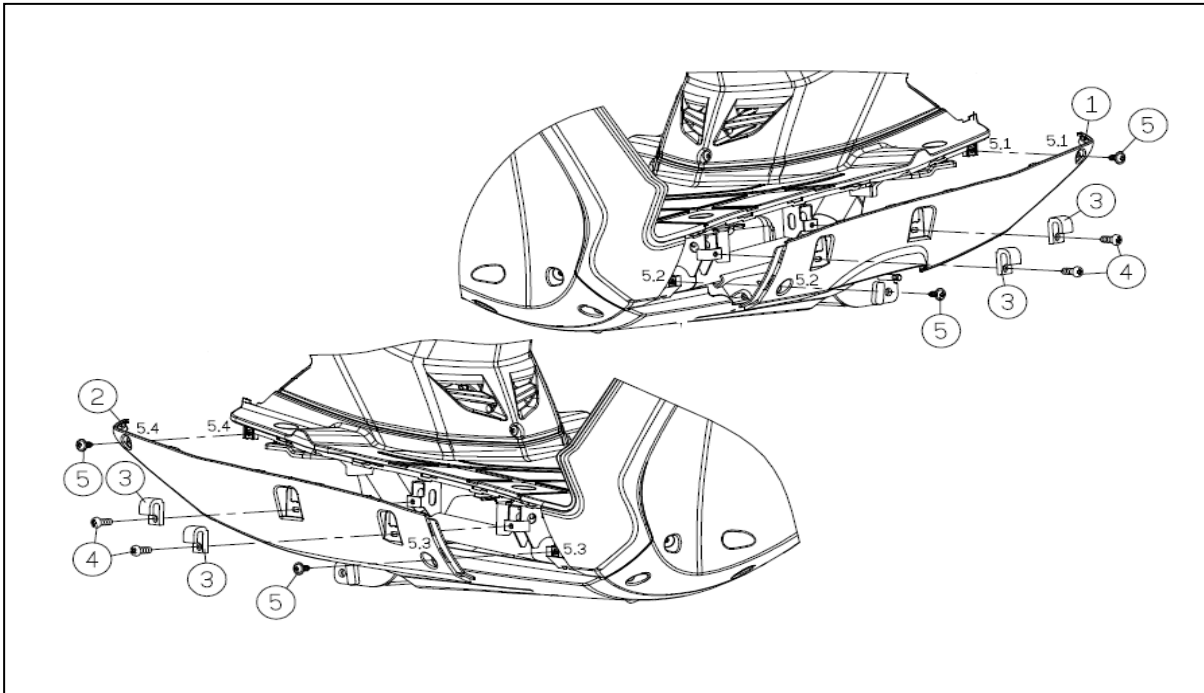

* dismantle-

1. Remove the screws(4/5) , take out the footstep floor lower cover(1/2).

* install-

According to the reverse procedure as above.

Installation or Removal of External Components- 2

NOTE:

* dismantle-

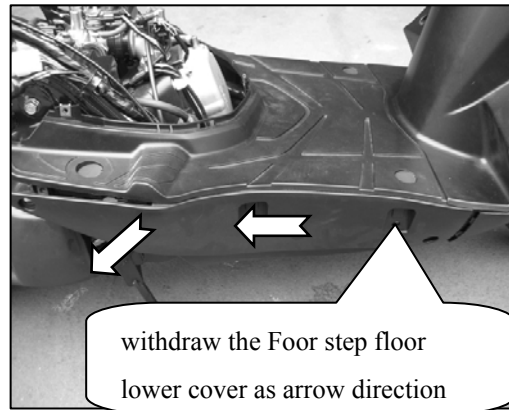
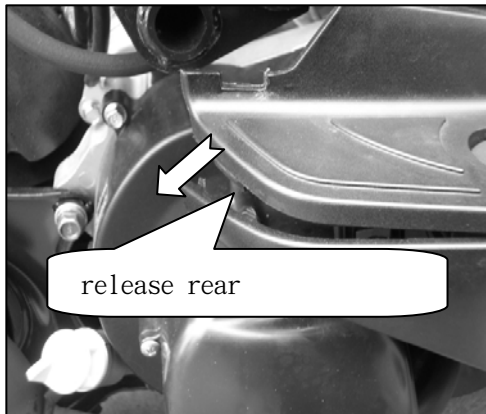

* install Floor step floor lower cover-

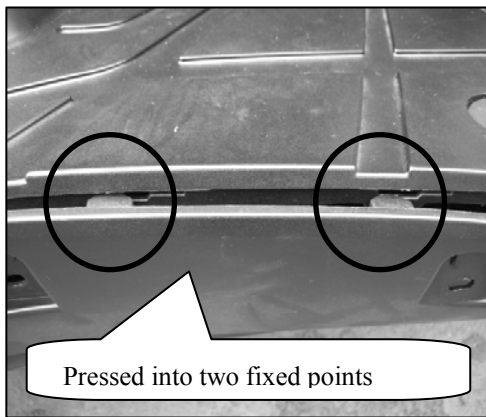

➤ Dismantle Tank lower cover

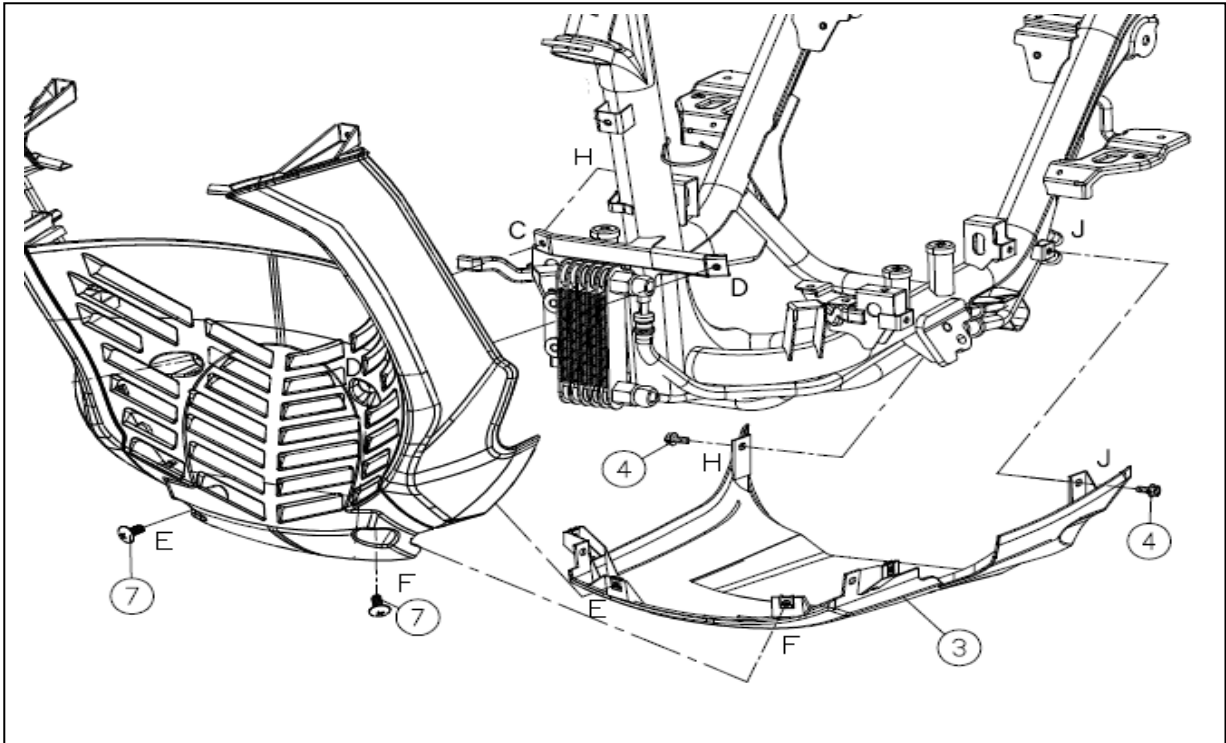

* dismantle-

Remove the screws(4/7) · take out the tank lower cover(3).

* install-

According to the reverse procedure as above.

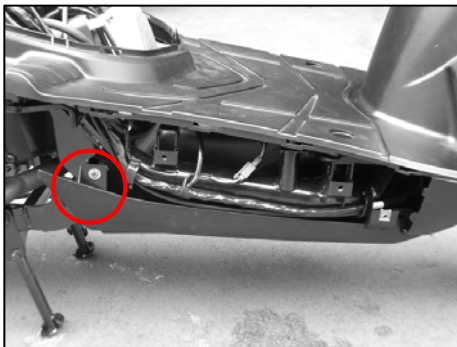

➤ Dismantle step-floor

* dismantle-

1. Remove the screws(2) – Figure1.

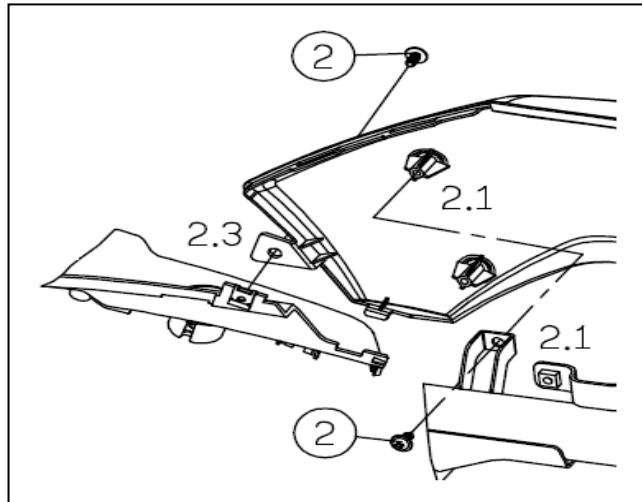

2. Remove the rubber plug (5)- Figure2.

3. Remove the screws(4) , take out the step-floor(2) – Figure2.

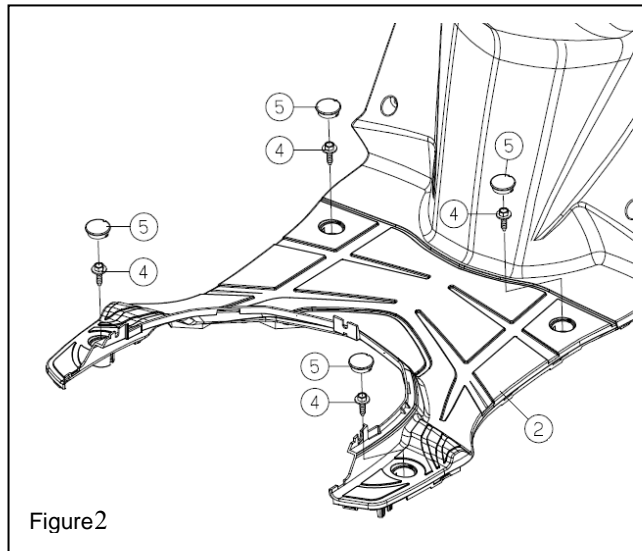

Figure2

* install-

According to the reverse procedure as above.

Note:

* Dismantle-

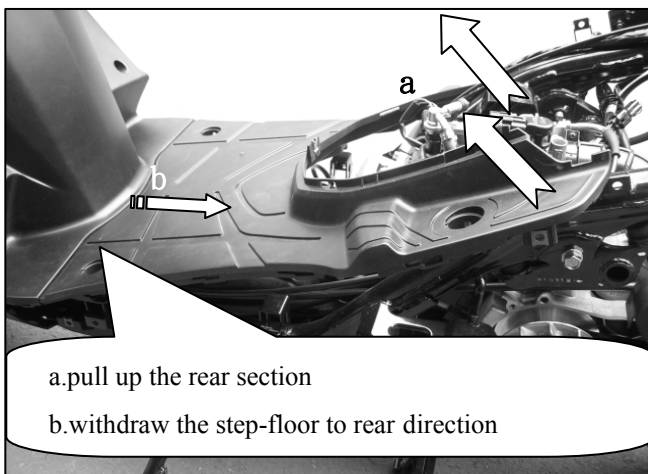

a.pull up the rear section

b.withdraw the step-floor to rear direction

Installation or Removal of External Components- 2

* Install-

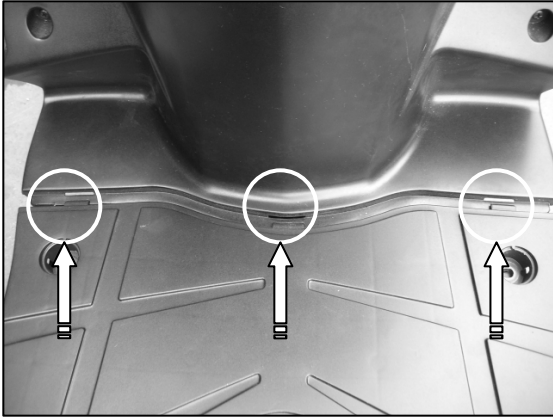

Single decomposition - Step-floor

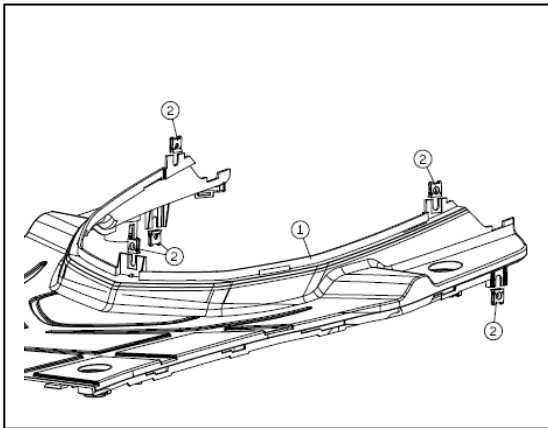

Parts2: U TYPE SPRING NUT

➤ Fuel tank

* dismantle-

1. Remove the screws(5) , take out the support holder of step foot(3/4).

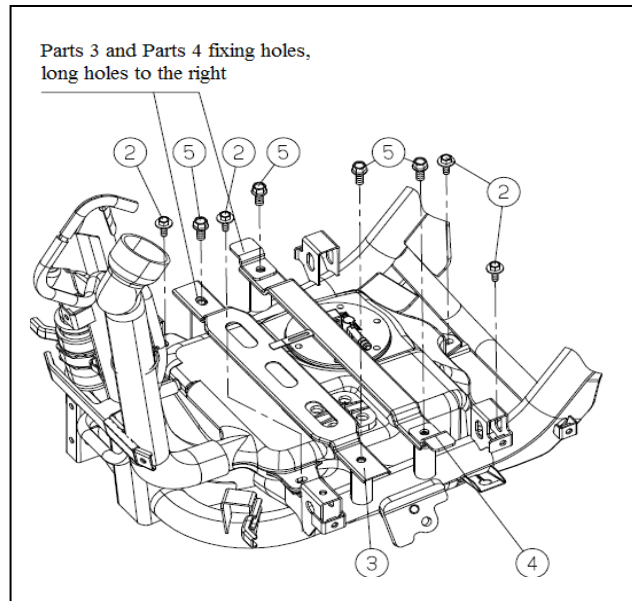

2. Loosen the clip(5) , take out the gasoline hose(4).
3. Use needle-nose pliers to remove the clip(7) , take out the three way assy(6).
4. Use "Hose clamp removal tool" to open clip(3), take out the oil pipe(2).

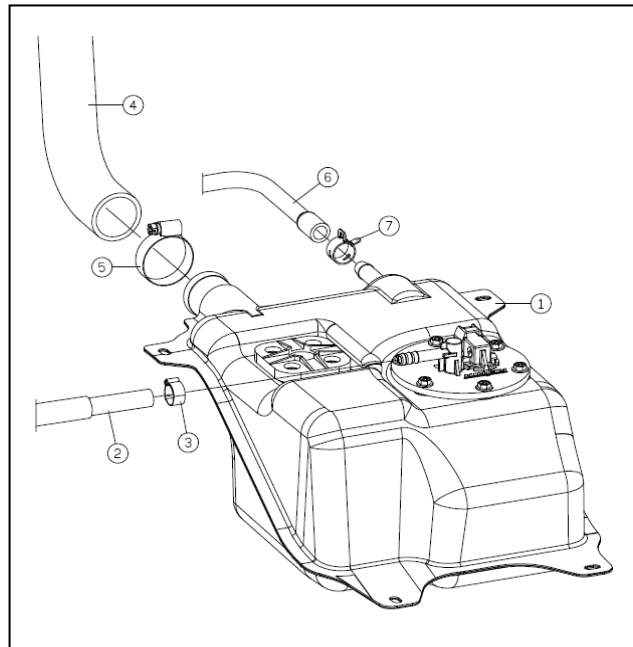

* install-

According to the reverse procedure as above.

➤ Fuel Pump/ Fuel guage

* dismantle-

1. Remove the screws(4) , take out the Fuel Pump (2) and O ring(3).
2. Remove the screws(6) , take out the Fuel guage (5).

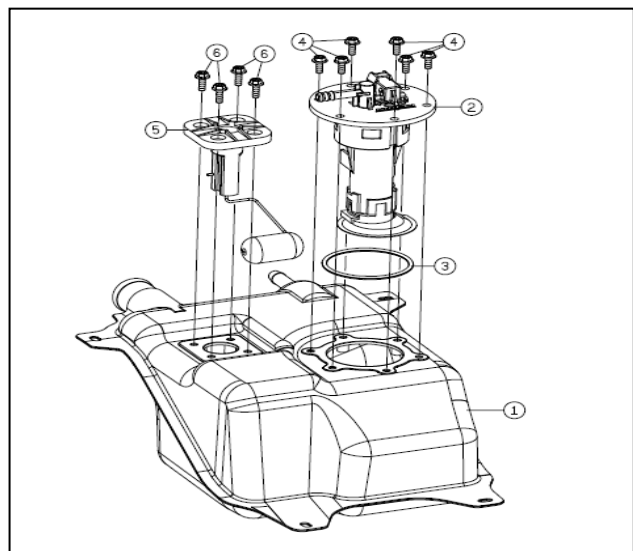

* install-

According to the reverse procedure as above.

Installation or Removal of External Components- 2

➤ FRONT LOWER COVER / UNDER COVER

*dismantle-

1. Remove the self-tapping screws (1).

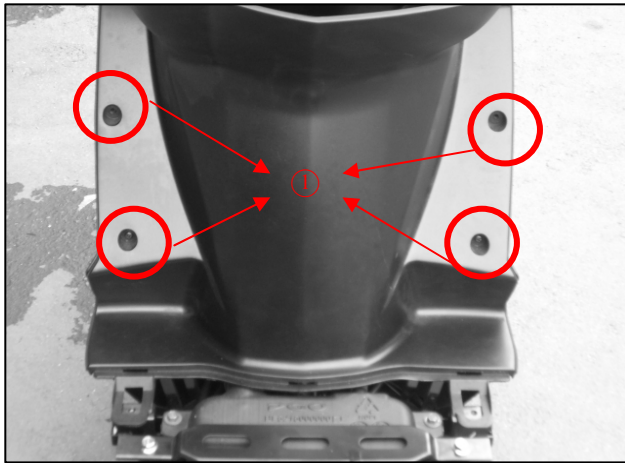

2. Remove the self-tapping screws (2).

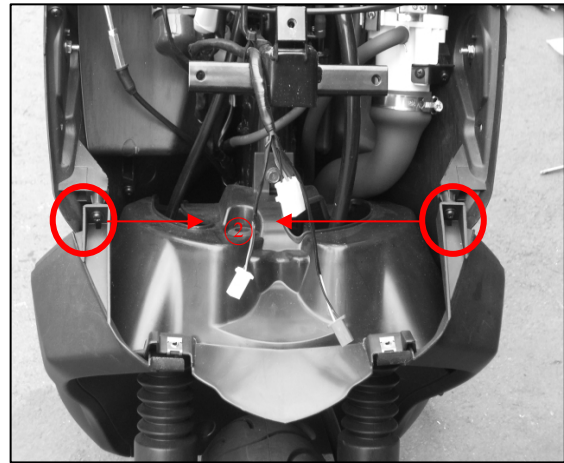

3. Remove the self-tapping screws (7) and hex bolts (4), take out the under cover (3).

4. Remove the bolts (6), take out the front lower cover(5).

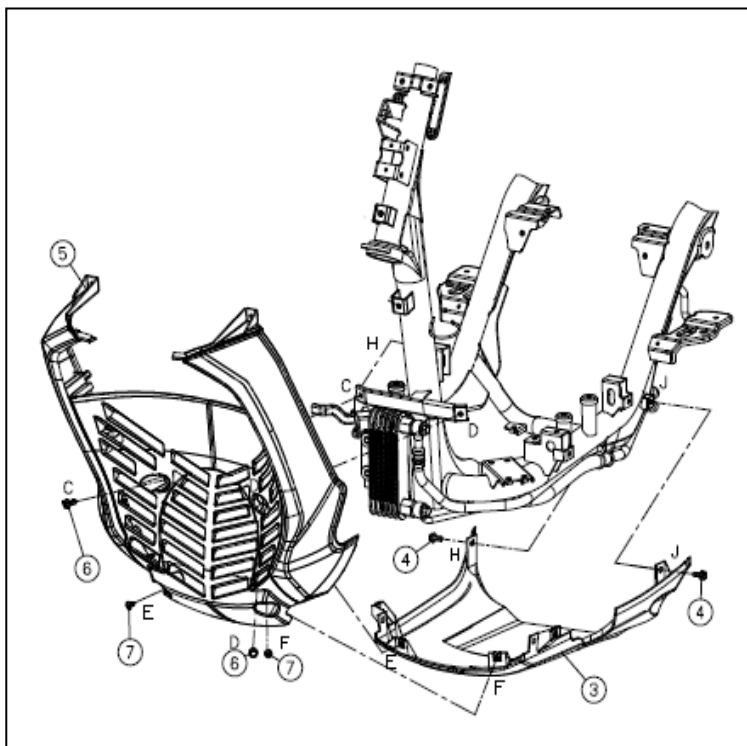

➤ Dismantle front-inner cover

* dismantle-

1. Remove the screws (8).
2. Use the magnet burglar key, remove the magnet burglar lock assy(3).

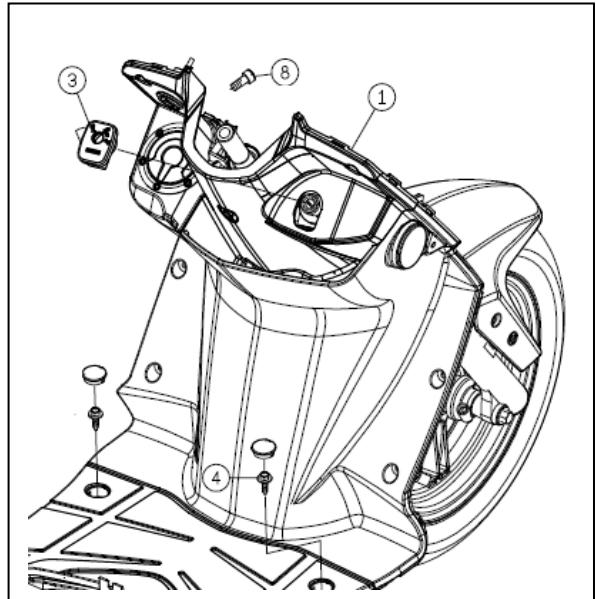

2. dismantle the fuel cap cover turn counterclockwise and pull out.



3. Remove the screws (1) , take out the gas cap base.

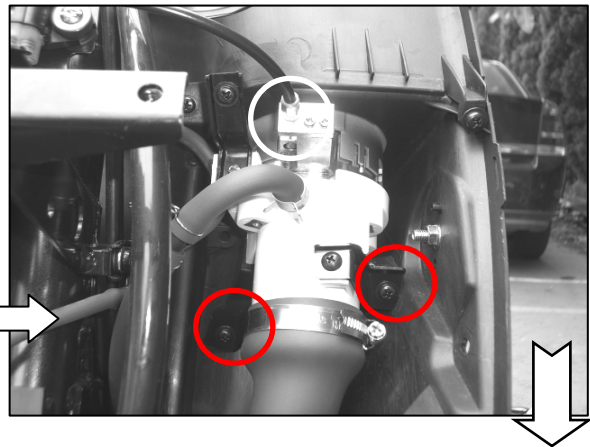

4. pull back the cover.



* install-

According to the reverse procedure as above.

Installation or Removal of External Components- 2

Single decomposition – front inner cover

* dismantle Step-

1. Remove the bolts (6), take out the side reflectors (5).
2. Remove the self-tapping screws (8), separated front inner cover-upper (7) and front inner cover-lower (1).

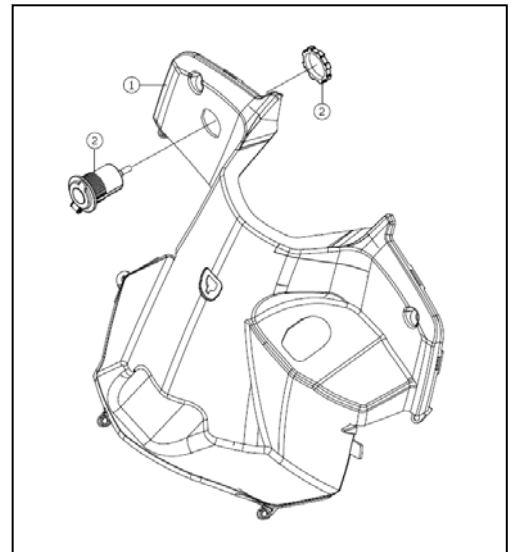
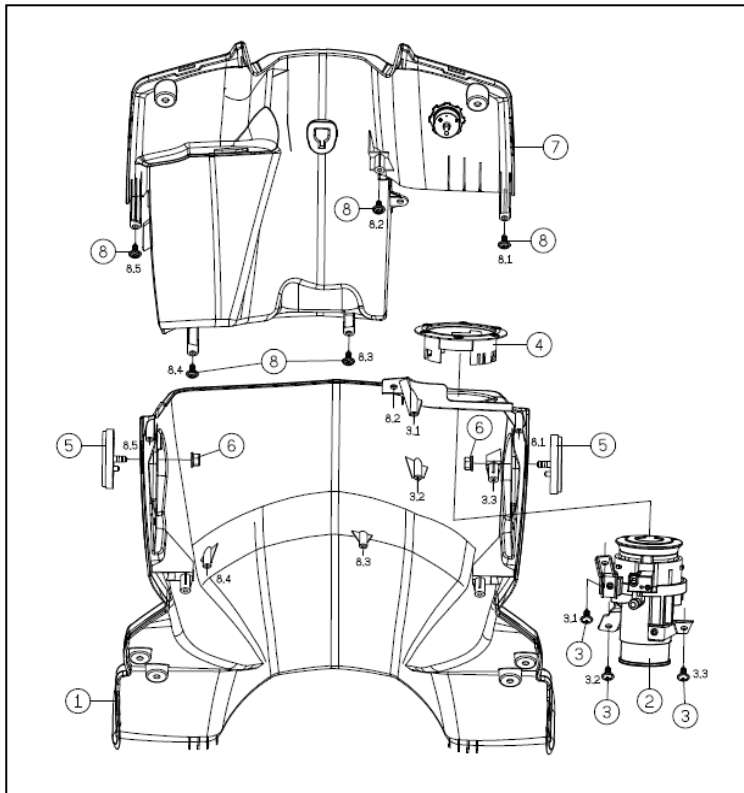

* Install-

According to the reverse procedure as above.

Installation or Removal of External Components- 2

Single decomposition - GAS CAP BASE

* dismantle Step-

1. Remove the Phillips head screw (5), take out the Gas cap fixing plate-B (4).
2. Remove the Phillips head screw (3), take out the Gas cap fixing plate-A (2).
3. Remove the Phillips head screw (7), take out the Gas cap fixing plate-C (6).
4. Remove the Phillips head screw (9) and take out Fuel tank cover (8).

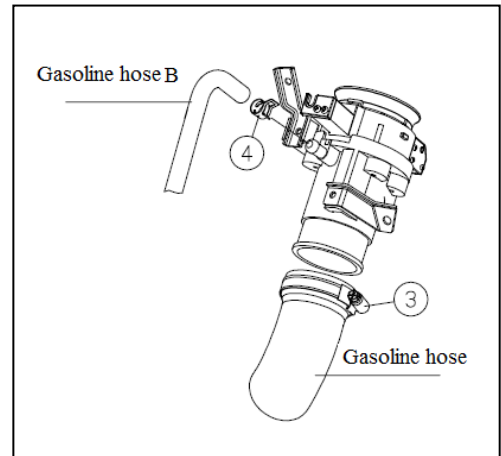
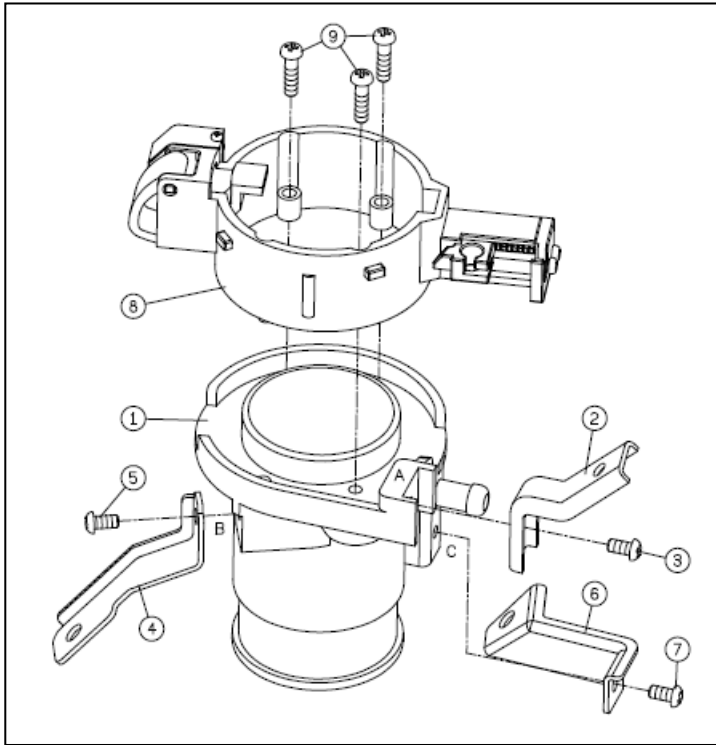

* Install-

According to the reverse procedure as above.

➤ Removable front inner fender

* dismantle Step:

- 1.Remove the front fork assembly (see 6-2).
- 2.Remove the bolts (2) , take out the front inner fender (1).

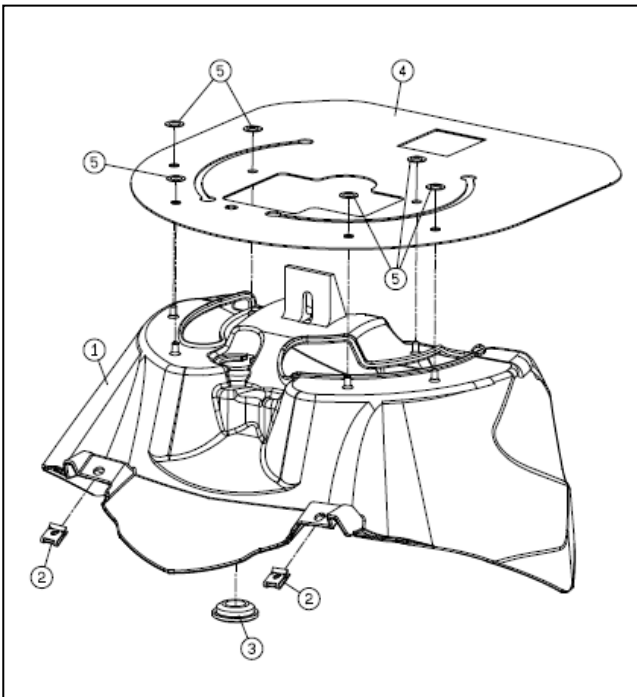
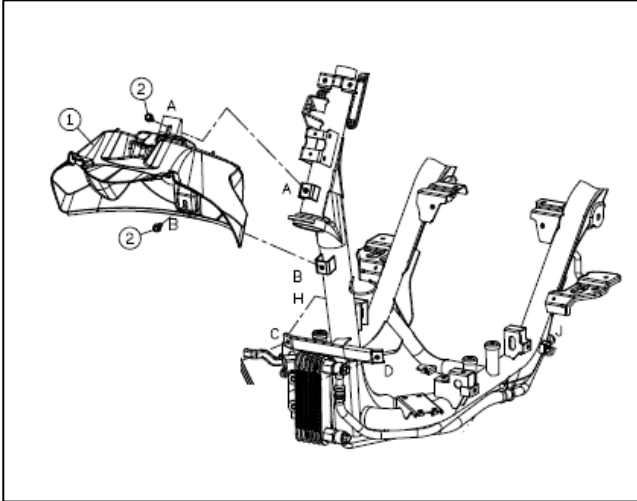

* install

According to the reverse procedure as above.

3-1 Engine oil

Volume:

Total oil volume: 1000c.c.

Oil volume replaced: 800c.c.

Service cycle: Every 1800 mile

Check the oil level:

- ◆ Park the motorcycle on a horizontal surface for check.
- ◆ Start the engine for 3-minute running and stop it for another 3-minute; make a measurement.

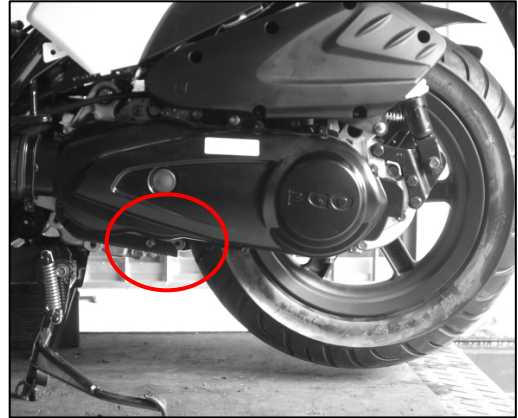

1. Remove the oil meter counterclockwise and clean it.
2. Screw the oil meter into the filling orifice to measure the oil level.
3. The oil level should be higher than the lower limit but lower than the upper limit. Add any engine oil for oil insufficient.

△Note: Some disadvantages such as engine damage and performance deterioration may be attributed to engine oil out of the range.

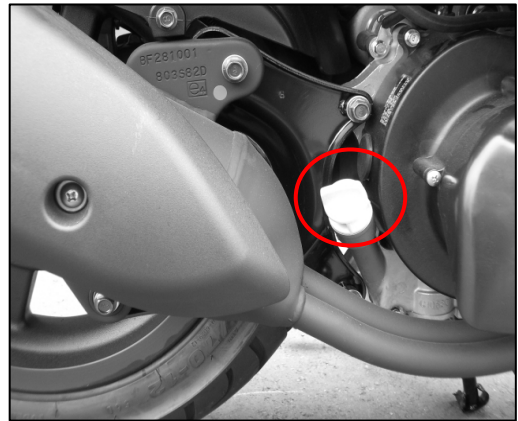

Oil replaced

1. Remove and clean the drain plug bolt; check the gasket for any defect and replace the defective gasket with a new one. Screw the bolt with the engine oil evacuated.
2. Remove and clean the oil meter. Add new engine oil to 800c.c. (volume replaced) and screw the oil meter.
3. Start the engine and check any engine oil leaked; remove the oil meter and check the oil level again.

Drain plug bolt (engine oil) Torque: 2.5~3.0(kg-m)

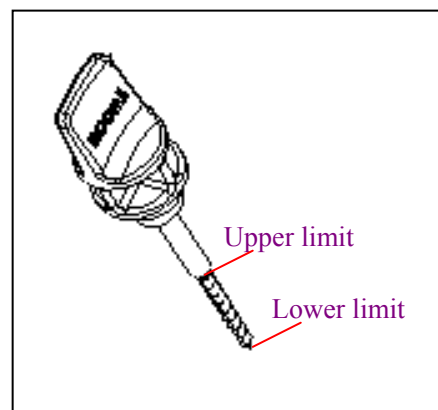

△ Note: Engine oil to be replaced shall be 1000c.c. for the engine disassembled and installed.

3-2 Gear oil

Volume:

Total oil volume: 110c.c.

Oil volume replaced: 90c.c.

Service cycle: Every 1800 mile

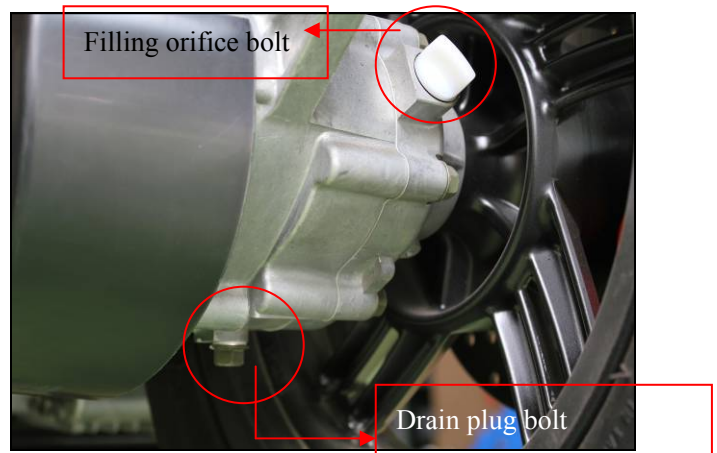

Check the oil level:

- ◆ Park the motorcycle on a horizontal surface for check.

1. Place a graduated cup under the drain plug bolt prior to removal of the bolt.
2. Check the oil volume after the gear oil is evacuated.

Oil replaced

1. Place a vessel under the drain plug bolt; remove and clean the bolt.
2. Install the bolt with the gear oil evacuated.
3. Open the filling orifice and pour new gear oil; tighten a filling orifice bolt.

Torque: 1.2~1.8(kg-m)

△Note: To avoid oil leakage, please check the aluminum gasket attached to the drain plug bolt and the O-ring attached to the filling orifice bolt for any deformation.

3-3 Air cleaner

Recommended service cycle:

Check: Every 1800 mile

Change: Every 3600 mile or less than 3600 mile
in the event of filth.

Check / Change

1. Remove 8 set screws on the air filter cover.
2. Check packing for filth or damage; clean packing with high-pressure air gun.
3. Replace the air filter with a new one in the event of the old one too filthy.

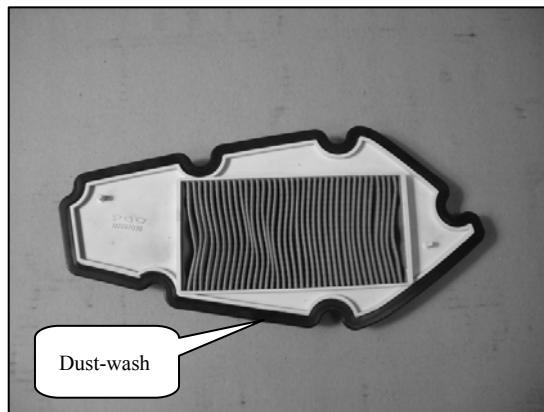
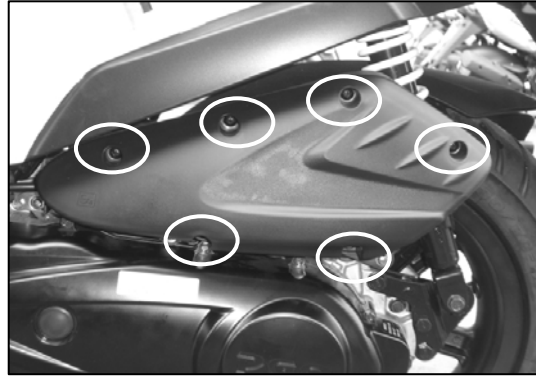

△Note:

Do not rinse packing with water or organic solvent.



3-4 LCD SPEEDOMETER

1. Engine speed
2. Signal indicator
3. High beam indicator
4. Oil warning lamp
5. Fuel gauge indicator
6. velocity
7. ODO/TRIP
8. EMS check
9. SELECT
10. ADJUST

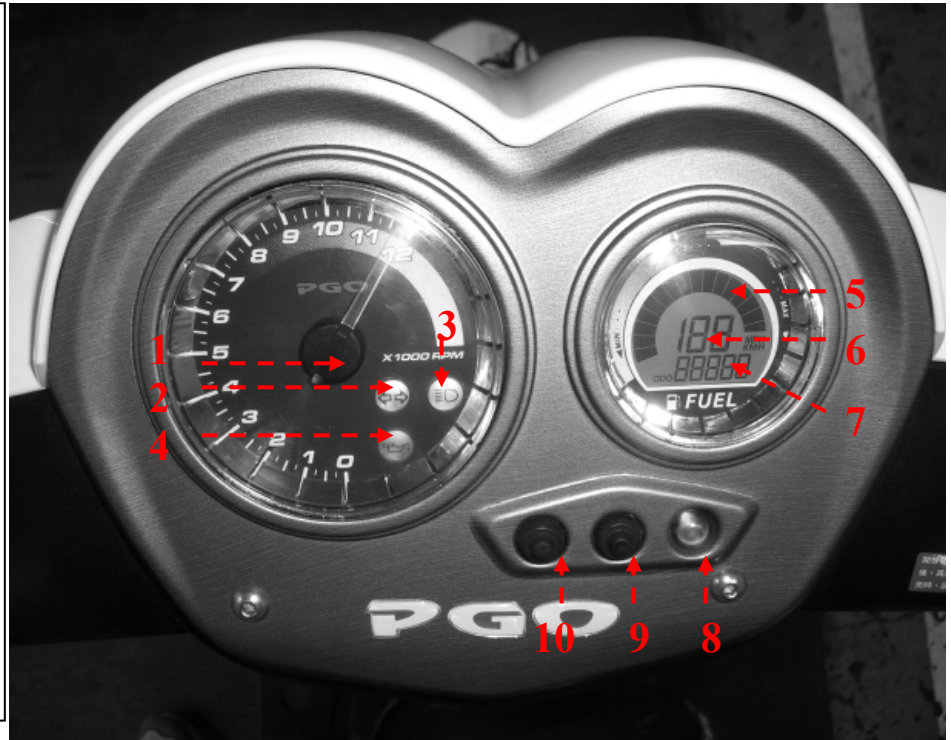

mode \ function	key	display	SELECT	ADJUST	result
Vehicle speed	ON	km	Click		Mile
		mile	Click		Km
(ODO)/ (TRIP) switching	ON	ODO		Click	TRIP
		TRIP		Click	ODO
Reset (TRIP)	ON	TRIP		Click 3 sec.	Reset TRIP to 0
Reset (4T oil indicator)	ON	Forever ON	Click 3 sec.		twinkle
		twinkle		Click 3 sec.	OFF
Cancel Reset (4T oil indicator)	ON	twinkle	Click		Forever ON

1. turn on main key
 2. light on: self test for about 5 seconds
 3. light off, could start the engine
- * if EMS check light on during driving, find PGO dealer to inspect as soon as possible.**



3-5 Main switch

1. All the power is cut off, the key can be pulled out at this position (B).
2. The power is ON, engine can be started, the key can not be pulled out at this position (A).
3. The handle bar is locked at this position (D).
4. "Push + turn counterclockwise": to open the seat (E).
5. When at position #1, "Push + turn clockwise" to open the fuel cap (C).

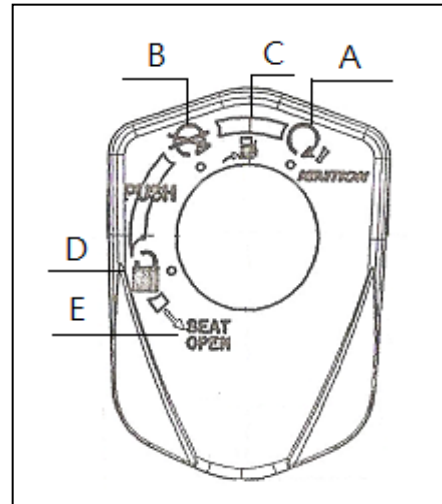

Main switch cover removable :

1. Remove Wind shield, the set screw and remove.

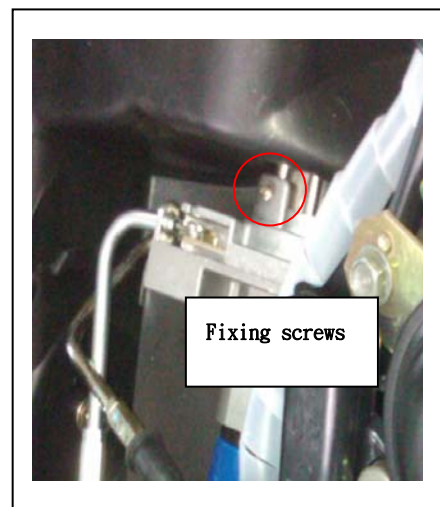

Fuel tank cap

1. The key to power OFF position.
2. The key under the pressure and turn right , Open the fuel filler.
3. Use 92 or above unleaded gasoline.

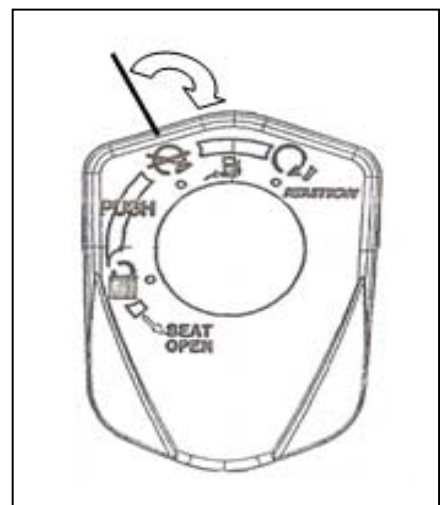
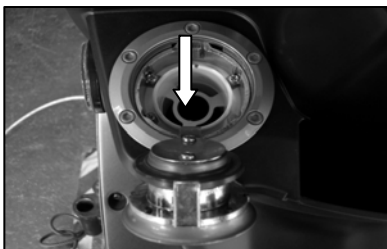

Seatlock:

Push the key and turn counterclockwise to open the seat.

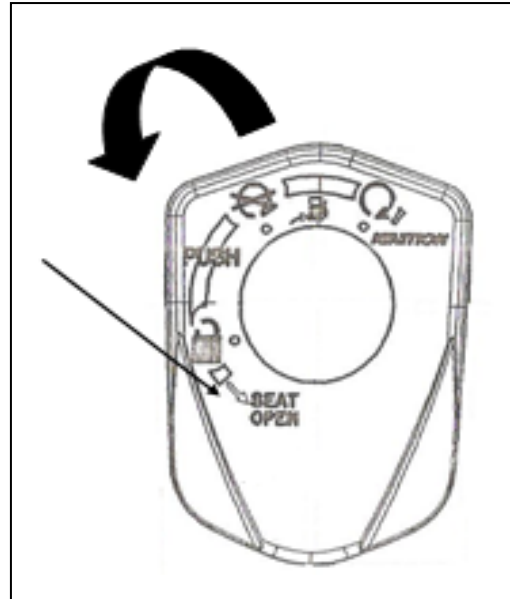

3-6 Seat lock / Fuel tank cover adjustment

a- Seat lock lever cable.

b- Tank cover lever cable.

Adjustment screws:

Clockwise: Tighten

Counterclockwise: loosen

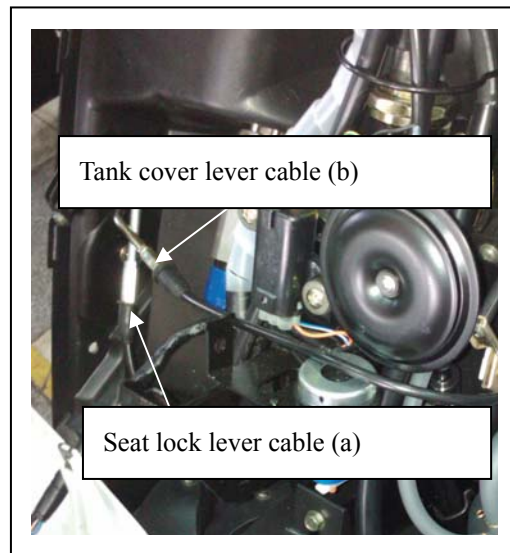

3-7 Battery installation

1. open the battery cover.
2. take out the band, tool set.
3. install battery, fix with band.
4. fix positive cable.
5. fix negative cable.

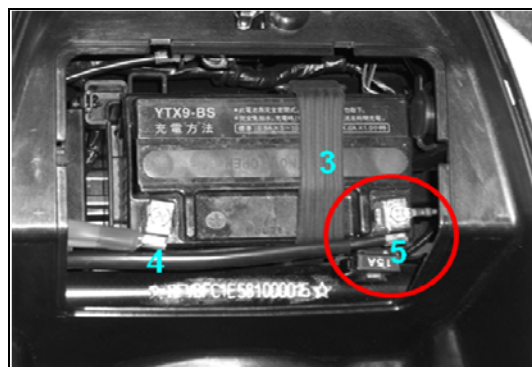
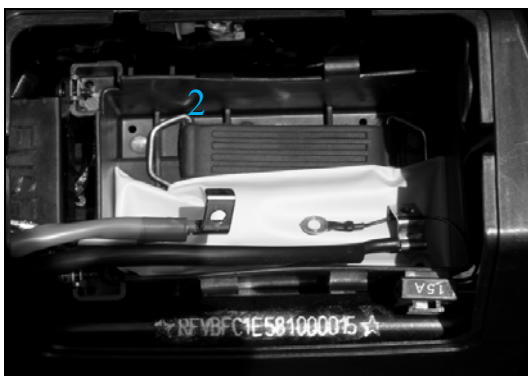

3-8 Spark plug

Check:

1. Use a spark plug socket to remove the spark plug.
2. Check the spark plug for damage, filth, or carbon deposition.
3. Use carbon remover or a steel brush to clean any filth or deposited carbon.

Specific model:

CR7HSA NGK or similar substitute

Spark plug gap: 0.6~0.7mm

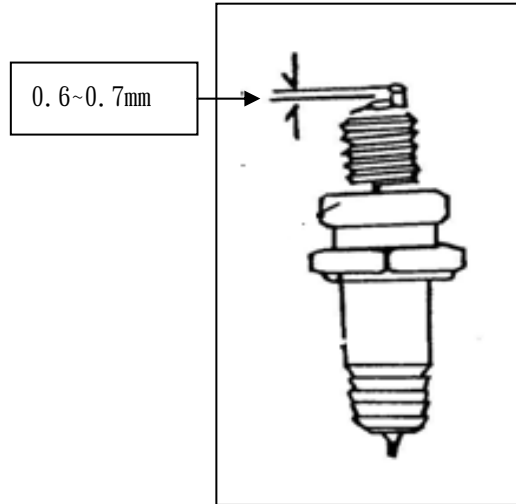

3-9 12V Charging power switch

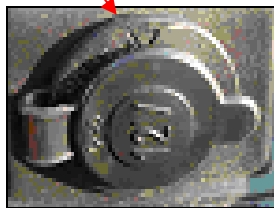
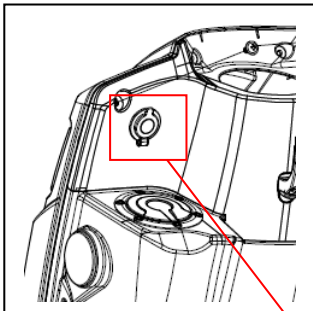

- 1.Function: Supply 12V DC voltage, the charging power.
- 2.Restrictions on Use: The charging current is not higher than 1A.
- 3.Power Protection: 1A fuse.
- 4.Usage: car charger into the charging hole can.

Note:

The power supply can not be used when the cigarette lighter.

3-10 Engine timing check / adjustment

1. Demolition - order

> Please refer to the engine disassembly.

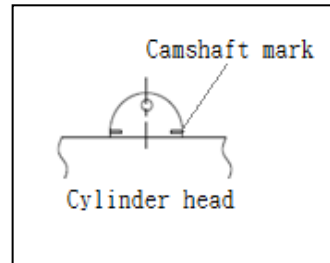
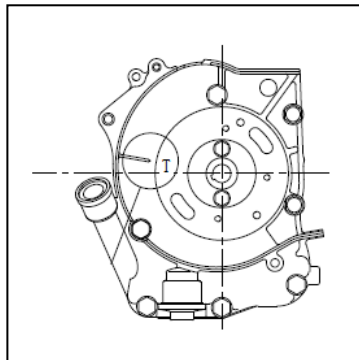

2. Check – timing

- › Clockwise rotation of the flywheel, the flywheel "T" mark aligned with the instructions on the right crankcase cover ribs above.
 - › Check camshaft large hole in Vertices, and the other two small hole (or horizontal line) is parallel to the cylinder head.
 - › No parallel
- Adjustment - camshaft sprocket position.

3. Adjustment - camshaft sprocket position.

- › Remove the inner chain adjuster screws of the adjusting hole.
- › Use a slotted screwdriver into the hole, clockwise the adjustment screw locking within the chain becomes loose.
- › Remove the camshaft holder nut * 4.
- › Adjust the camshaft sprocket on the horizontal line with the cylinder head of the cylinder head cover parallel to the joint surface.

4. Installation-

> Reverse installed in accordance with the demolition order.

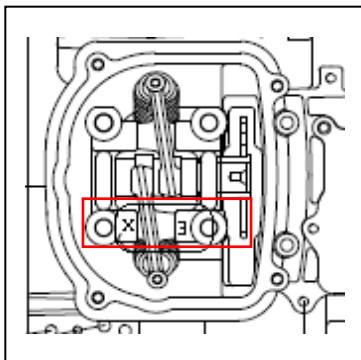

Note:

When you install the camshaft holder "EX" mark side should face the exhaust side.

3-11 Valve clearance check / adjustment

1. Remove - order

> Please refer to chapter 7 cylinder head.

Note

- .1). Valve clearance adjustment, measurement adjustments in the cold when.
- .2) Measurement and adjustment, go to your piston top dead center position.

2.Measurement - valve clearance

> Tools: feeler

> Valve clearance: IN: 0.08mm

EX: 0.08mm

> Check the way:

- a: Rotate the crankshaft to adjust the piston top dead point (the flywheels T points aligned ▽).
- b: Use a feeler gauge to measure inlet and exhaust valve clearance is within the specified range.
= 0.08mm feeler = IN / EX: can be placed in non-home = 0.10mm
Out of range → adjustment

3. Adjustment -

> Tools: Valve adjustment tool

> Adjust the way:

- a: loosening the lock nut.
- b: thickness gauge is inserted between the valve and the adjustment screw.
- c: Shun or counterclockwise rotation adjustment screw, straight
To be adjusted to a predetermined value so far.
- d: re-measure the valve clearance, if the valve clearance beyond
Standardized, re-adjust.

Torque:

Adjustment bolts: 0.7kg-m



4. Installation:

> Reverse installed in accordance with removing the sequential manner.

3-12 Throttle cable free clearance check / adjustment

1. Check -

- > Check the idle speed is too high.
- > Rotate up and down the right grip, check the throttle cable clearance.
Whether large or small, please adjust exceeded the standard value.



2. Measurement - the throttle cable free play
Standard value: 2 ~ 6mm

3. Adjustments - throttle cable free play

- a: Loosen fixing nut
- b: clockwise or counter-clockwise adjustment screw
Until Within the standard range.
clockwise (1) = Tighten
Counterclockwise (2) = loosen
- C: Tighten the fixing nut

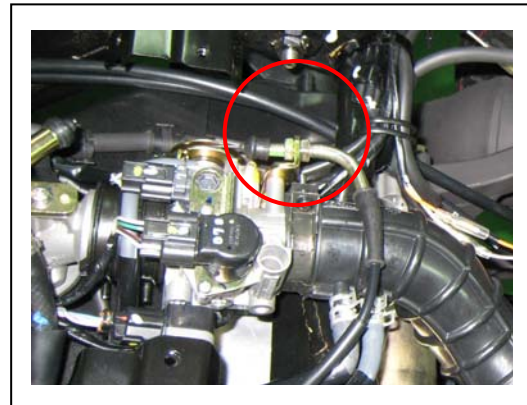

NOTE

The throttle the ropes free gap adjustment, the handle tube to the left, Then turn right in the end, check the fuel wires would interfere Lead to engine speed becomes higher.

3-13 Brakes-thin check

› **Standard values:**

The front brakes -thin: 5.0mm
After brakes -thin: 5.0mm

- › Use limits: front: 4.3mm (Less than 0.7mm replacement)
After: 4.0mm (Less than 1.0mm replacement)

2. Measurement -

- > Brakes-thin to the film thickness
Out of range →
Replacement (trench polished)

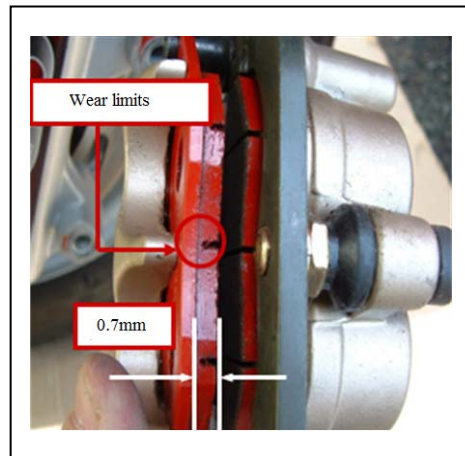

front brakes -thin

NOTE

- 1. The brake pads to reach the usage limit replace the whole group.
- 2. Brake pad attached to the surface of the oil, will reduce braking performance, severe cases may endanger life.

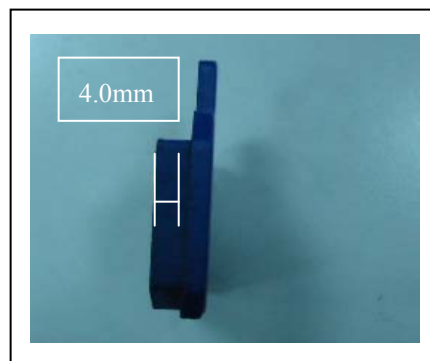

After brakes -thin

3-14 Brake fluid check / adjustment

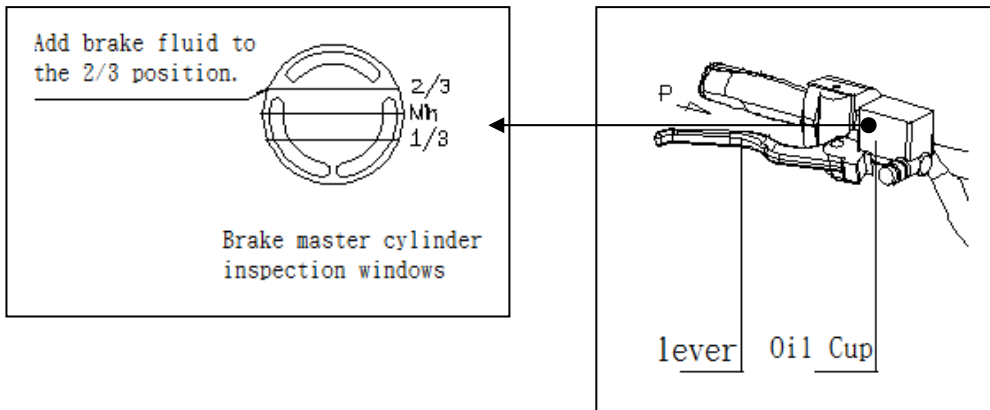

1. Check - brake master cylinder

- > Brake oily (View Mirror 2/3) whether the amount of high oil And between the low oil level (MIN).
- > Out of range -> add or reduce the amount of oil.

Adjustment:

- > Open brake master cylinder cover, add brake fluid to the standard oil.

NOTE:

- 1.Brake fluid is corrosive, if the brake oil cup or bodywork have to dip Brake fluid, rinse with water.
- 2.Brake fluid can not be mixed with other oil.
- 3.DOT4 not be use mixed with DOT5.

★Recommended oil: FMVSS DOT4

3-15 Headlight adjustment

Adjustment:

Remove the windshield ; Turn the adjustment screw using a Phillips screwdriver, the average adjustment left / right screw. The beam to be projected could be changed by moving the reflecting plane's angle upward or downward.

Lamp spec: H4 12V55W (HI- H1)
35W (LO- HS1)

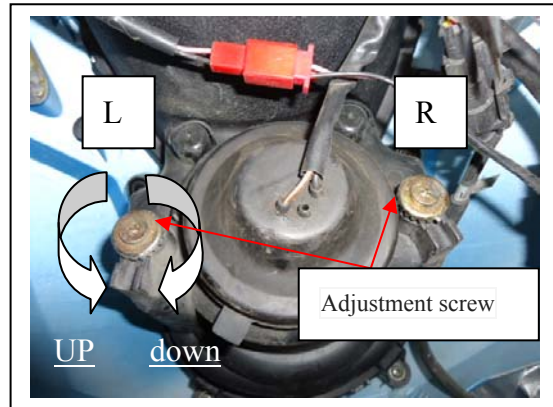

Adjusting screw to change angles of beam projected

3-16 Tire

1. Check-

› Tire pressure

Tire pressure		
	Front tire	Rear tire
Single	1. 8kgf/cm ² 25psi	2. 0kgf/cm ² 29psi
duet	1. 8kgf/cm ² 25psi	2. 0kgf/cm ² 29psi
Basic weight (Including oil and gasoline)	126KG	
Maximum load	150KG (Passenger /goods)	

NOTE:

- ◆Please check the tire pressure in the cold.
- ◆Gross vehicle weight must not exceed tire load,easy to make the tire burstor damage caused by a vehicle accident.
- ◆The total weight does not include the Knight,passenger, accessories and cargo.

2.Check-

- › Tread/tire wall:
replacement tire→ wear, cracks
- › Tread depth:
Minimum usage limit: 0.8mm

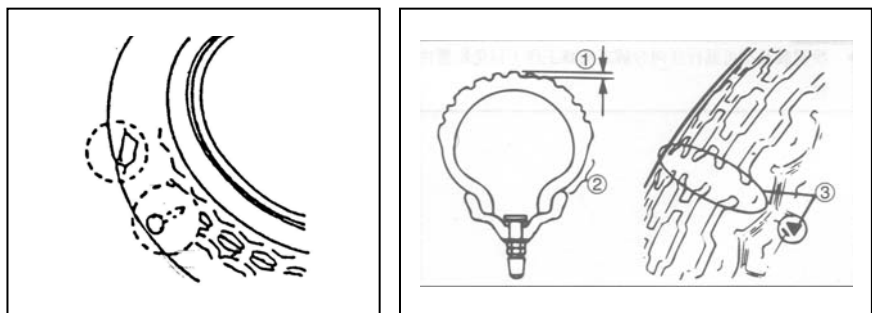

› **Tire specification:**

Front tire: 120/70-12
Rear tire: 130/70-12

Depth (front and rear): According to the mark of tire”▲” indicating the necessity to change a new tire.

3-17 Battery check

1. Demolition -

> Battery cable

By:

> First demolition of the battery cable

(-) negative, then split the battery lead (+) positive.

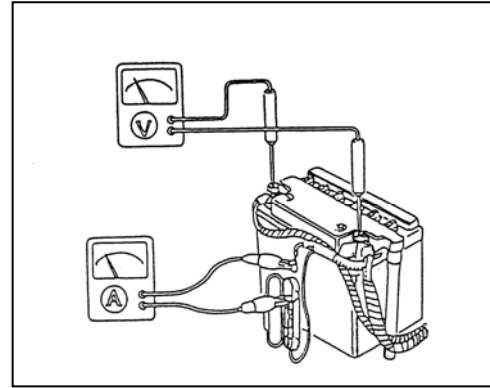

2 check - battery voltage

Tools: multimeter

Ways: (+) red probe is connected to the positive terminal

(-) black Probe is connected negative terminal

State	voltage	method
Fully	12.8V or more	-
Charging	12.3V~12.7V	to charge
No electricity	12.3V following	to charge

(Minimum start-up voltage: 12.3V)

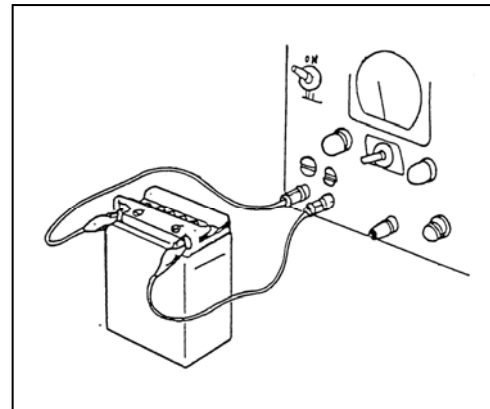

3. Charging current / time: the 0.9A / 5 ~ 10 hours

Note:

- 1)Do not rapid charge.
- 2)Sealed battery cover Never open the battery cover so will lead to the battery internal imbalances degrade performance.
- 3)In order to give full play to the battery performance battery before use the battery implementation of the initial charge.
- 4)New battery added to the electrolyte, allowed to stand for 10 to 30 minutes or more and then into the sealing cap, allows the electrolyte completely soaked pole portions, i.e. with fully characteristics.
- 5)Locomotive unused for long periods: When the locomotive is not used for long,please be placed before the first supplementary charge, at the same time remove the negative terminal, preservation, custody during a monthly supplement electric once only please.

4.Installation:

> Battery cable

By:

- 1)First install the battery lead (+) positive,and then installed the battery cable (-) negative.
- 2)Positive / negative terminal smear on the butter.



3-18 V-belt - air sponge cleaning

1. Demolition -

- > Remove of clamp bolt (1) Loosen.
- > Remove the breather pipe (2).
- > Remove to remove the fixed plate (3).
- > Remove the sponge (4).

2. Checks -

- > sponge is excessively dirty – replacement.

3. Cleaning -

- > Using powerful compressed air to clean the.



Note:

Do not use flammable solvents to clean (eg: petrol) sponge.

4. Installation:

- > Installed in accordance with the demolition order reverse.

3-19 Fuse check

Note:

Removable fuse , the main switch cut to the OFF position.

Check:

- > Tools: multimeter
- Way: red probe(+) then fuse either end
black Probe(-) connected to the other end of
- > Multimeter stalls: Ω
 $\infty \rightarrow$ replace a Fuse

Note:

- . Lock cut the power to the OFF position.
- . Please replace the fuse of the same amperage.
- . Replacement again blown fuses, check Denso line.

Installation:

Installed in accordance with the demolition order reverse.

Warning-

Do not replace the fuse greater than originally set specifications, may cause the vehicle fire.



3-20 drain valve

Gasoline pipe exclude air and inferiority oil:

1. dismantle the under cover.
2. find the drain valve.
3. turn on the key.
4. press the drain valve, fuel drained & air bleed.
5. repeat #3~#4, until fuel is clean.

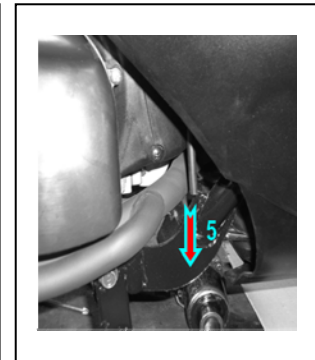
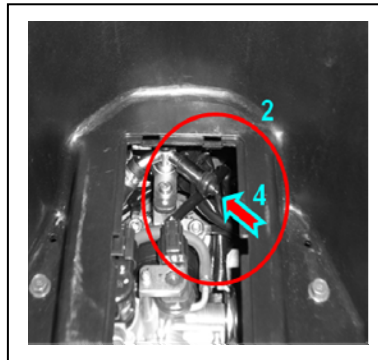

*timing

1. brand new vehicle after assembly.
2. long time storage.
3. stored more than 2 weeks of used vehicle .
4. replace fuel pump, fuel hose, injector.

View confirmation

1. Check whether the escape of gasoline.
2. Check the escape of gasoline is normal color.
3. Check the escape of gasoline is bubble-free.

3-21 CVT

※The counterweight Roller Installation Notes

1. put the driving face as below.

2. install the upper roller.

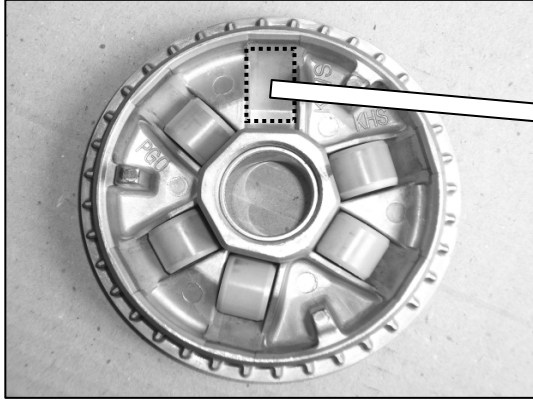

3. the close end face to left.

4. install the others.

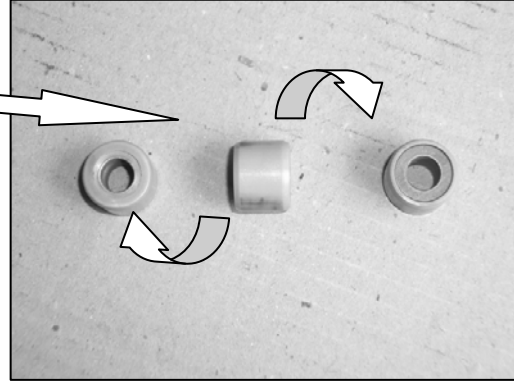

CVT Installation Considerations-

- Press the v-belt into the driven pulley as deep as possible.
- Installing the v-belt, make sure the digitals face to the operator.
- Assemble the driven pulley assy first.

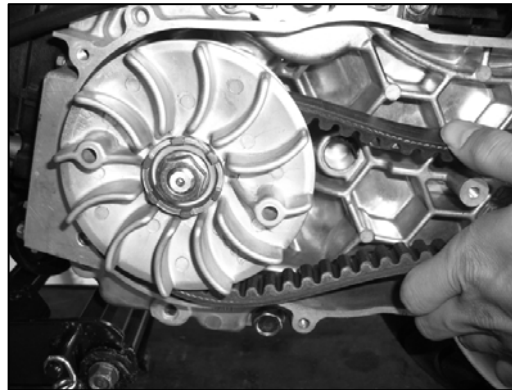

NOTE:

1. General version of the CVT system, follow the standard normal maintenance operations.
2. Cargo version of the CVT system, each regular maintenance, the implementation of simple checks (short road test), check the clutch without severe wobble or abnormal sound? Roller without serious wear? V-belt is aging cracking?

3-22 Compression pressure measurement



1. Demolition -

- > Spark Plugs

NOTE _____

Removable spark plugs, use compressed air to clean around

Prevent dirt drop the spark plug hole. _____

→ Make sure that the compression pressure combustion chamber whether coke, if less than the minimum value

Pressure values	Reason
The numerical higher than did not add oil before	Piston rings bad
Equivalent to not add oil before	Valve, piston, piston rings Cylinder head gasket and other adverse

2. Measurement - cylinder pressure

Standard value: $10 \pm 2\text{Kg/cm}^2$ -570rpm

Tools: compression pressure gauge

› Measurements -

- a. The power open to ON position.
- b. full throttle, turn on engine until the compression pressure value is steady.
- c. Test results:

1.If more than the maximum value

→ Make sure the combustion chamber whether carbon deposition.

2.if less than the minimum value

→ Please add a few drops of oil to the cylinder in the spark plug hole , The re-measurement.

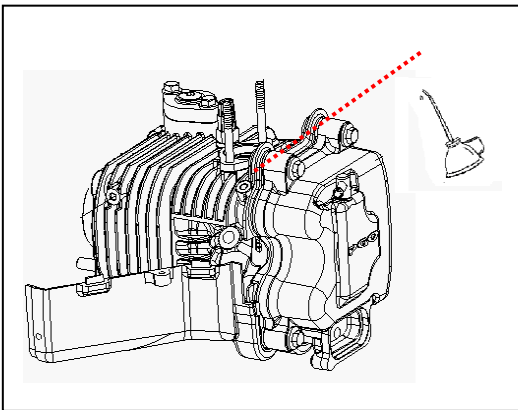

3. Installation -

- > Installed in accordance with the demolition order reverse.

Check & Adjust -3

PERIODICAL MAINTENANCE TABLE

In order to achieve safe riding, good performance and reduce pollution, please execute the recommended maintenance accordingly.

Item	Model	Checking Content	MONTHS/DISTANCE(IN KM)FOR CHECKING							
			1 or 200 mile	3 or 1800 mile	6 or 3600 mile	9 or 5400 mile	12 or 7200 mile	15 or 9000 mile	18 or 10800 mile	
Engine oil*	4T	Replace 800cc, total 1000cc	R	Replace it initially 200 mile, and then replace it per 1800 mile						
Coarse oil filter* (on oil draining bolt)	4T	Clean or replace it if necessary	C	clean it initially 200mile, and then replace it per 3600mile if necessary						
Oil Filter	4T	Replace	R	replace it per 3600mile						
Air cleaner	4T	Crack and blockage check.		I	I	I	I	I	I	
Air filter	4T	Clean or replace it if required		I	I	I	I	I	I	
Gear oil*	4T	replace 90cc, total 110 cc	R	R	I	I	R	I	I	
Disk & drum brake	4T	Leaking and function check		I	I	I	R	I	I	
Clutch shoes*	4T	Check or replace it if necessary			I	I	I	I	I	
Tires	4T	Worn-out check or replace it if necessary		I	I		I		I	
Wheel bearing*	4T	Fasten tightly if loosen		I	I	I	I	I	I	
Front fork*	4T	Leaking and function check	I		I	I	I	I	I	
Steering head bearing*	4T	Check looseness. Adjust it if required			I		I		I	
Rear absorber*	4T	Leaking and function check			A		A		A	
Main/Side Stand	4T	Function check or replace it if required		I	I		I		I	
Nuts, bolts, fasteners	4T	Tighten it if required		I	L	I	L	I	L	
Battery	4T	Recharge the battery it required. Clear the poles.		I	I	I	I	I	I	
Valve gap*	4T	IN&EX: 0.08mm/ When engine is cold	Adjust it when necessary		C	I	C	I	C	
Spark plug*	4T	Clear or replace if required		I	A		A		A	
V belt*	4T	Worn out check or replace if necessary.			R	I	R	I	R	
Fuel feeding system*	EXCE RT EMS	Crack and blockage check. Replace it if necessary.								
Fuel feeding system *	EMS ONLY (Injecti on)	Inspect hose, clamp, and			I		R		I	
Engine idle speed*	4T	engine: 1700±100 rpm	A	A	I		I		R	
EMS function check*	EMS ONLY (Injecti on)	Inspect EMS function, and clear the defect memory if necessary		I	A	A	A	A	A	

REMARKS :

1. A: adjust C: clean I: inspect, or replace if necessary L: lubricate R: replace
2. Items with “*” mark indicate our recommendation to have it done by GENUINE dealer.

NOTE 1 :

For 4T engine, the engine oil shall be changed completely after run-in period 200mile or one month later. This can make sure the engine runs smoothly.

NOTE 2 :

The exchange of brake fluid

1. After disassembling of brake main cylinder or caliper, do change the new fluid.
2. Check the fluid level often, Refill if necessary.
3. Change the oil seal of main cylinder and caliper every two years.
4. Change the brake fluid hose every four years.

Exhaust control system (only be valid for the bike equipped catalyst):

Catalyster will not be possible to be withdrawn individual, the only you have to do is to maintain fuel, ignition, intake/exhaust system periodically.

1. Maintenance procedure of air clearer (see page 35).
2. Spark plug's checking: please repair or replace if spark plug is dirty.
3. Fuel system's checking: please repair or replace if fuel pipe is jammed or broken.
4. Muffler's checking: please fix tightly once or renew a gasket if it is leaking.
5. Idle rpm's checking: please fix tightly once or renew a gasket if throttle cable.
6. Exhaust density checking while idle: please left the job to any service center of anti-pollution inspection for carburetor adjusting.

4-1 Second-generation injection system

Feature of 2nd-stage EMS

* feature

1. small, light
2. integrity
3. accuracy
4. simple

EMS structure (A)

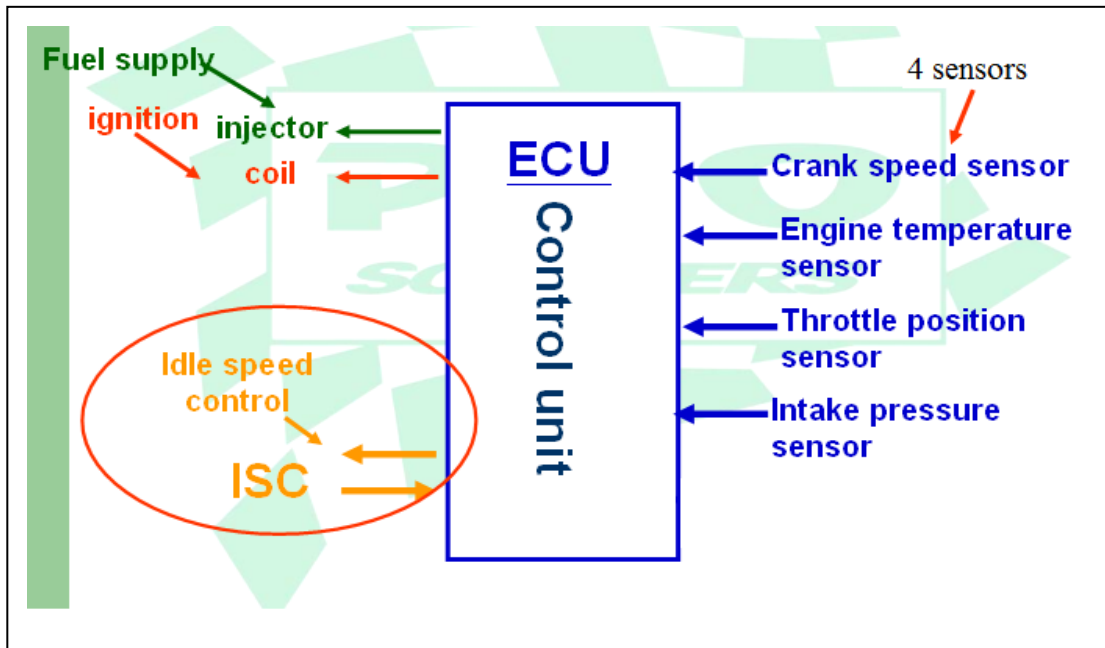

EMS structure (B)

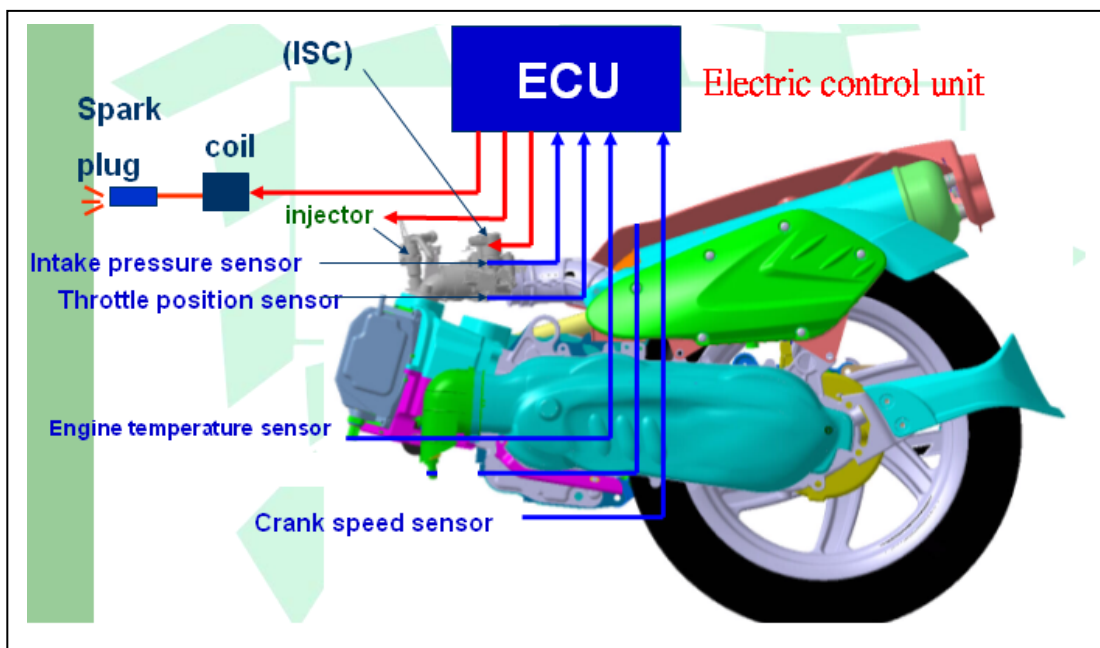

4-2 Electronic injection system introduced

4-2.1 ECU (electric control unit)

* Location

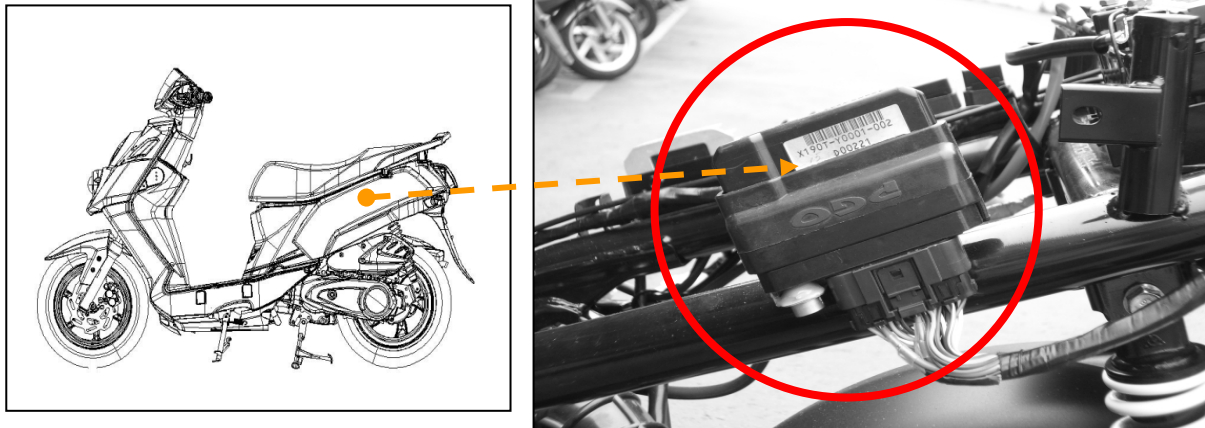

* Important PIN no.# of ECU

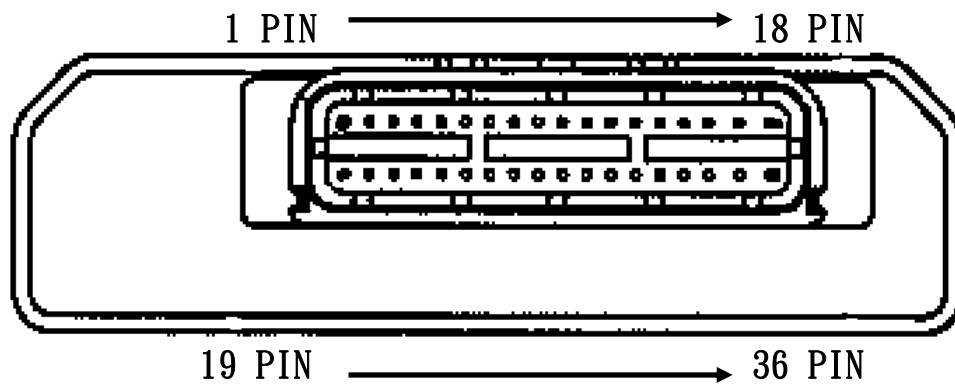

* Important PIN no.# of ECU

Fault phenomenon:
EMS lights lit
vehicle can not start

PIN NO.	function
11.	Control pole of fuel pump
12.	Control pole of headlamp relay
13.	supply(5V) voltage to sensors
16.	Control pole of injector
18.	Control pole of coil
19.	Input voltage from battery

4-2.2 Crank speed sensor

* Location

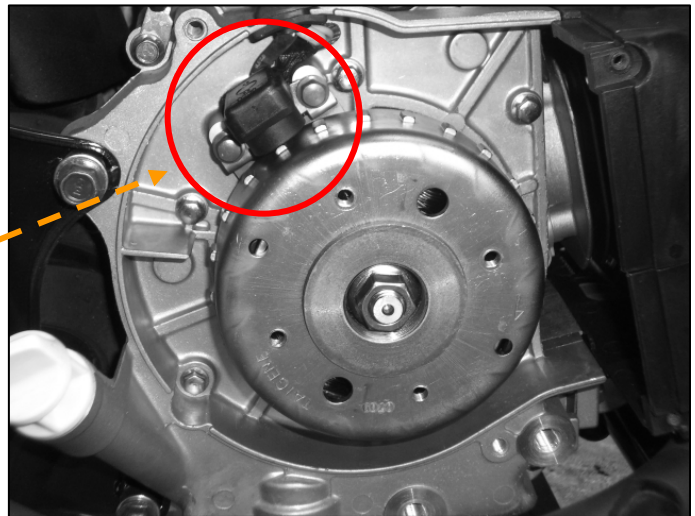
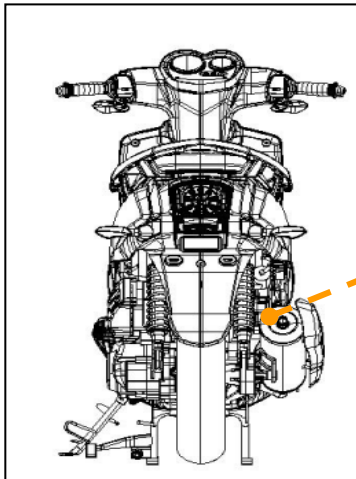

Function of Crank speed sensor:

- * function : induct the engine speed, tell ECU to control inject fuel & ignition.
- * theory : calculate the interval time of each flange on the outer.

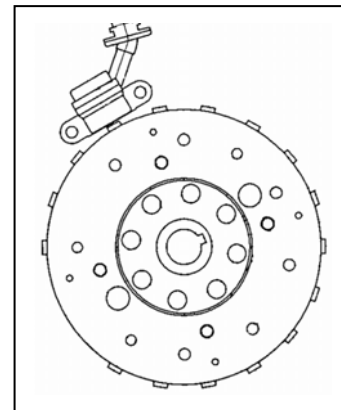

Fault phenomenon:

- 1.vehicle can not start
- 2.The spark plug no ignition with the fuel injector fuel injection
EMS light is on six long and six short(Crank angle perception circuit is broken or open circuit).

* Measurements to determine:

The measured crank angle perception cable, measured with a multimeter measurement (green and white with blue and yellow) to the amount of ohms stalls.

Measured values: $120 \pm 10\%$, such as open is the (NG) fault.

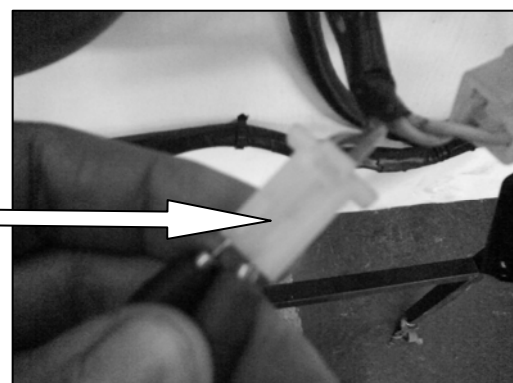

4-2.3 Engine temperature sensor

* Location

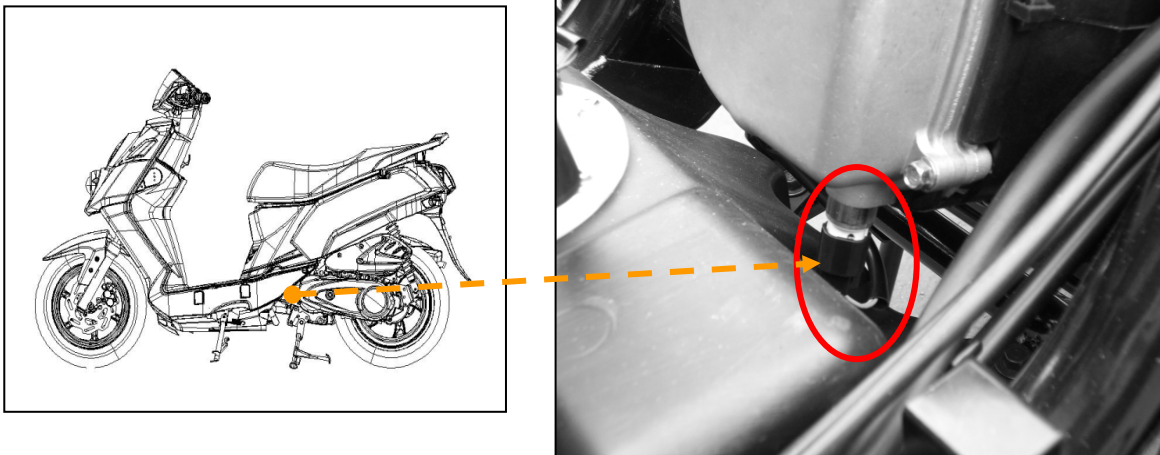

* The engine temperature sensor principle

Functions: sensing engine temperature to determine the hot and cold car conditions, the fuel injection quantity and ignition timing Correction compensation.

Principle: the use of high and low temperature, resulting in a change in resistance.

Measure engine temperature sensor:

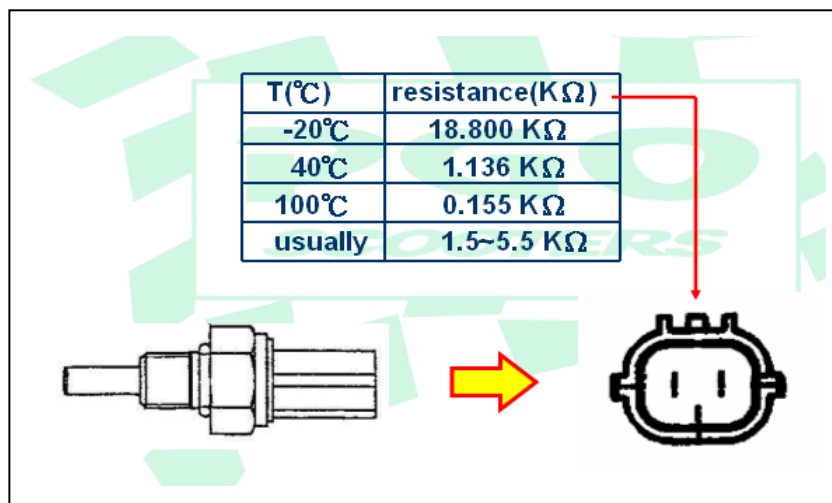

* Fault phenomenon:

The cold car hard to start, can not be judged as the hot and cold car.

4-2.4 Throttle position sensor (TPS)

* Location

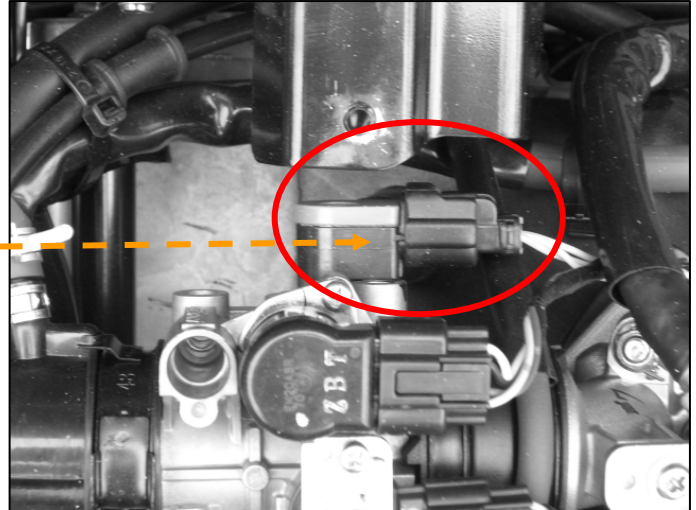
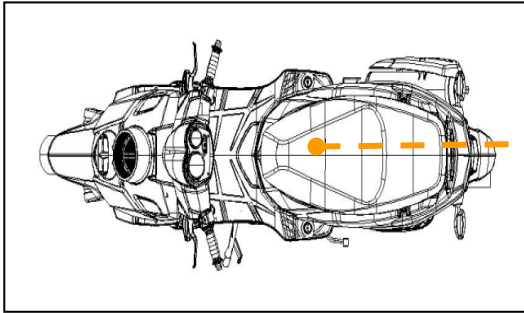

* throttle opening degree sensor (TPS) principle

1. functions: sensing the throttle opening to determine the driving situation, determine the amount of fuel injection and ignition timing.
2. principle: the use of the variable resistor, changes in the measured angle.

* throttle opening sensor (TPS) measurements

throttle	Lb(+) / Gr(-) output(V)
close	0.6 ±0.02V
WOT	3.8 ±0.10V

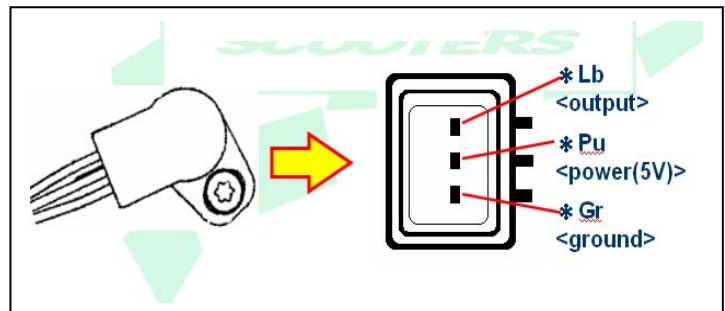

Fault phenomenon:

- idle speed high to 3000rpm or so throttle unresponsive.
- EMS light is on 0 length short (throttle opening degree sensor failure).

* maintenance Preliminary Gauge connected:

1. overhaul the initial impression: why the first check the failures lights, whether such failure of two or more.
2. failure phenomenon off with: As the throttle opening degree of perception failure, so can not provide the correct signals to the ECU can not determine the throttle opened so the slow throttle response, but also because of this reason for the prevention of engine speed when the throttle retractable low flame, the ISC will idle speed increased to about 3000rpm.

4-2.5 Intake pressure sensor

* Location

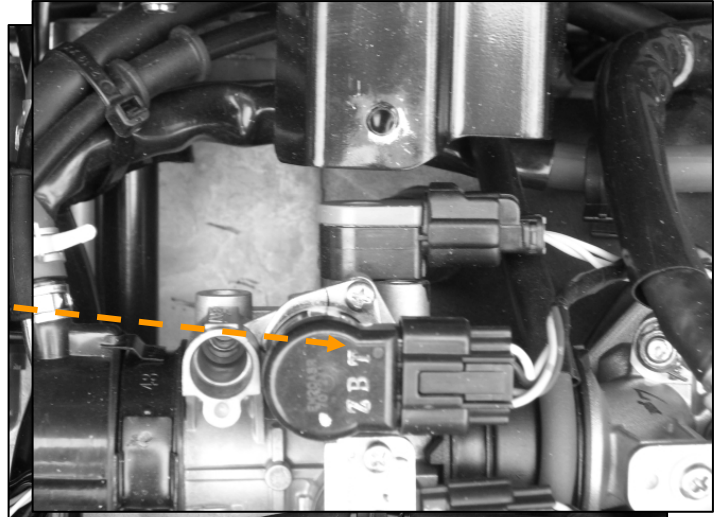
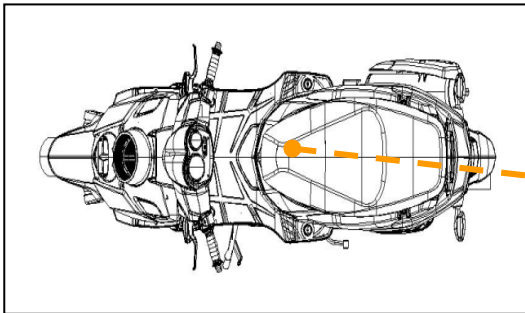

* Intake pressure sensor principle:

function : induct intake air pressure, ECU judge intake or compress stroke to decide injection & ignition.

theory : different pressure outputs diferent resistance.

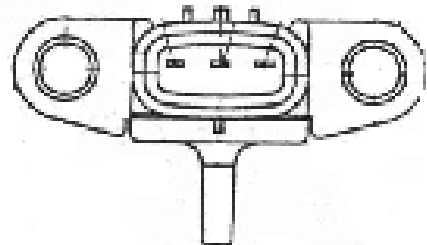

* intake pressure sensor measurement:

press(KPa)	G/B(+)/ Gr(-) output(V)
13.3KPa	0.5V
120 KPa	3.4V

*** average resistance in ambient**

wire	R(KΩ)
Pu(+)+Gr(-)	2~4KΩ
G/B(+)+Gr(-)	2~4KΩ

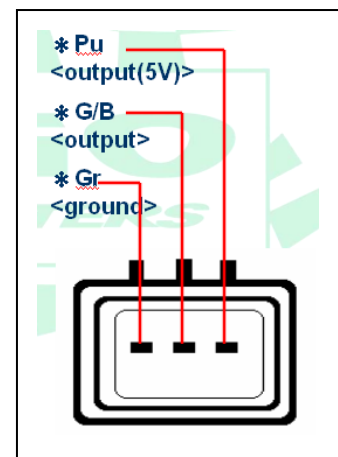
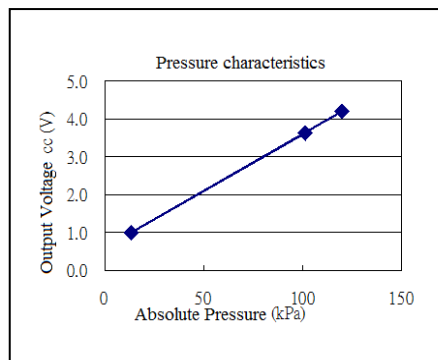

* fault phenomenon:

Idle speed will be lower than 1300rpm

idle speed will turn off possible

EMS light is on the long 9 short (intake pressure sensor failure)

4-2.6 Injector

* Location

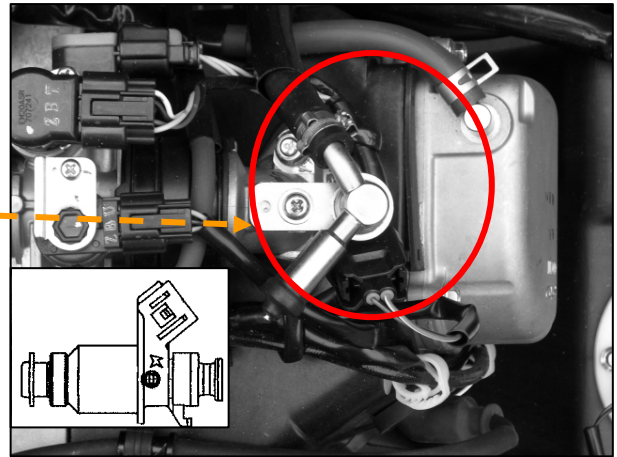
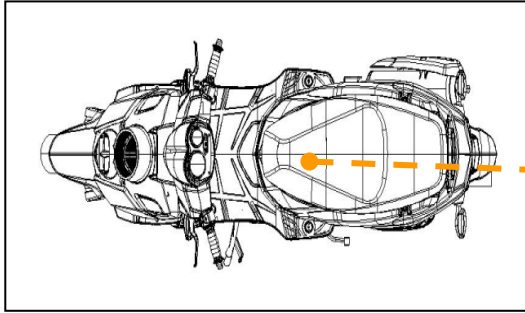

* Injector principle

function : inject the gas, mixed with air.

theory : control the opening time interval to decide the gas amount.

* Injector measurement:

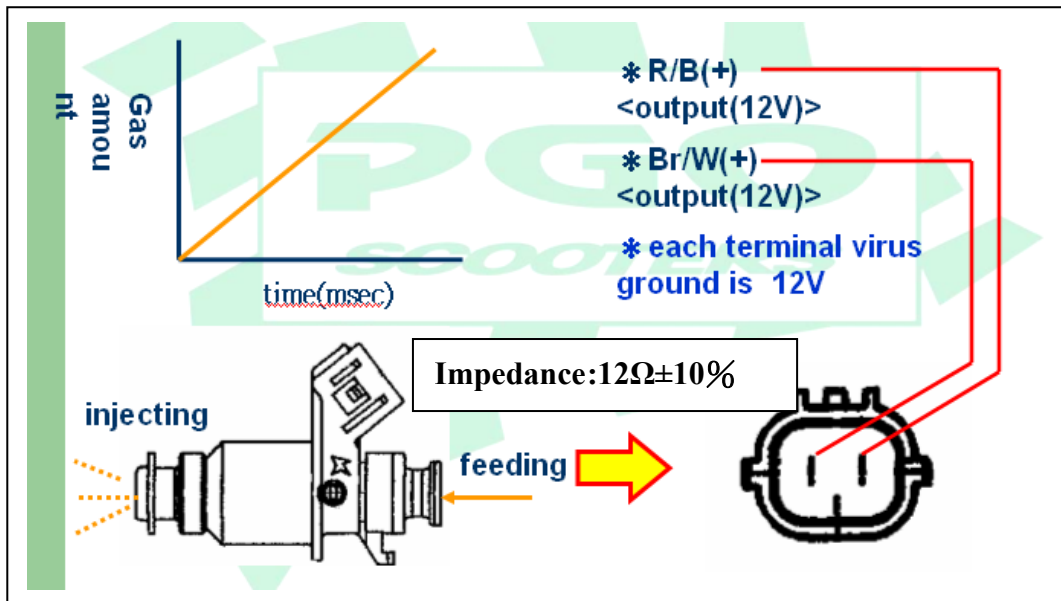

◆ Draining cap of injector

* bleed the air

Used when replace the fuel pump,pipe...etc.

* drain the gas

The gas inside the pipe may become poor quality after storage, drain it before start the engine.

* Fault phenomenon:

The vehicle difficult to start, or can not be launched.

EMS light is on three long 3 short (injector circuit open or break).

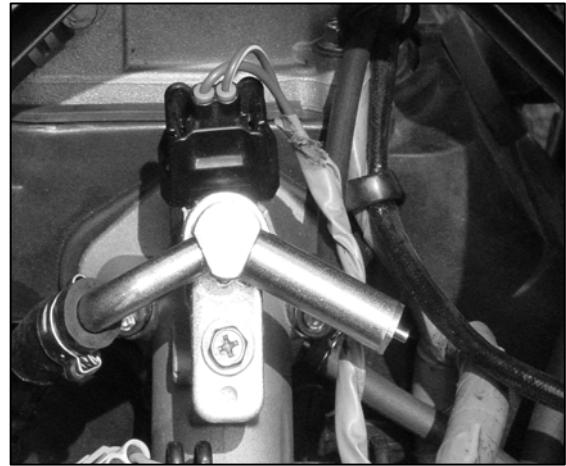

* overhaul of the initial impression method and connected.

initial impression method:

The first to confirm the fuel pump with or without oil, the nozzle cap to cover joints exhaustConfirmation. Remove the nozzle test, testing whether the injector. If there is no apparent fault code, but nozzle Not fuel injection , in addition to the remaining components has been detected, and the rest of the failure can be the initial impression for the nozzle block Plug.

4-2.7 Fuel pump

* Location

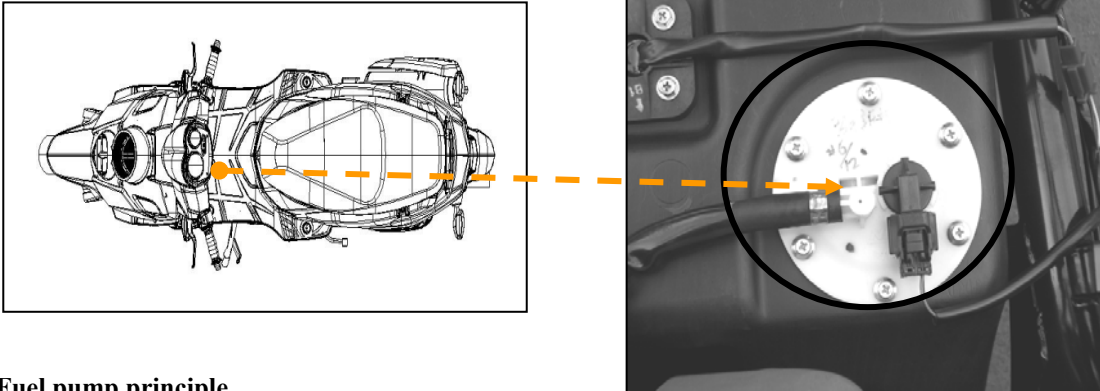

* Fuel pump principle

features: gasoline tank suction and control the nozzle gas pressure 3kgf/cm²

Principle: pressure adjustment allows gas pressure to maintain stability

* The fuel pump measurement

Nozzle internal line or external line break or open circuit photo into a spray ,The nozzle does not fuel injection. If there is no fault code generation does not have a line problem, should be able to determine for nozzle clogging.

	R/B(+)+B(-)
voltage	~12V
resistance	<1KΩ

* R/B(+)
<output(12V)>

* B(-)
<ground>

4-2.8 Fall down sensor

* Location

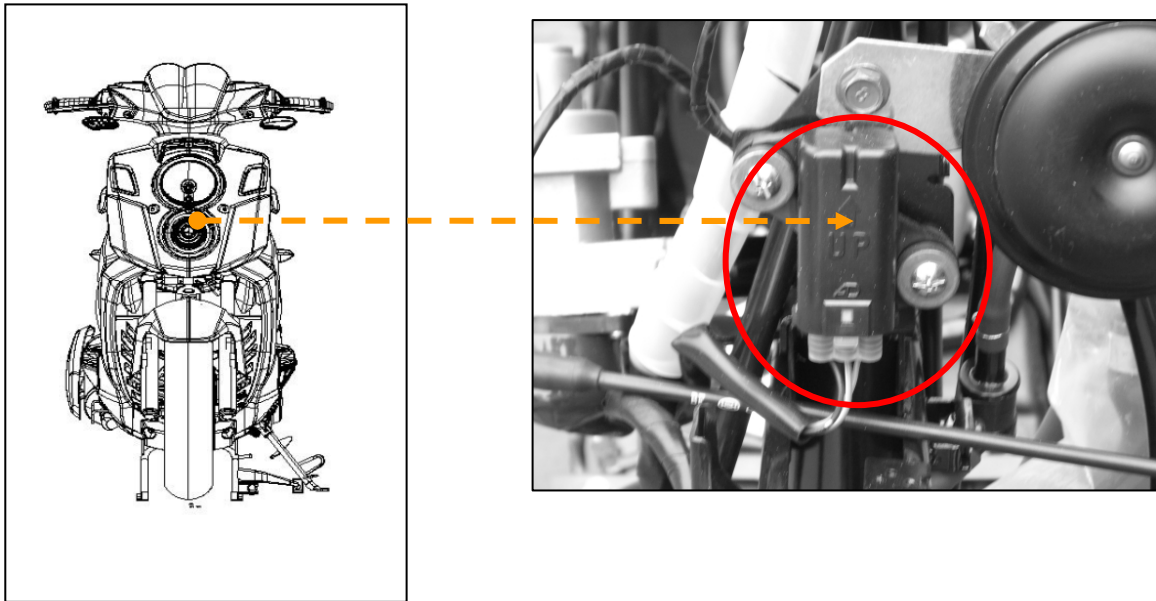

* Fall down sensor

Function: vehicles and dumping more than 65 degrees for any reason, you can cut off the power turn off.

Principle: the use of gravity to make the ball move position touch sensor vehicle dumping.

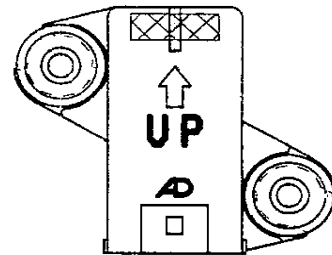

* Fall down sensor measurements:

power	degree	output(+) +ground(-)
OFF	any	OFF
ON	<65	ON
ON	>65	OFF

* to recover the sensor function after fall down :

- 1.turn OFF the key
- 2.turn ON the key

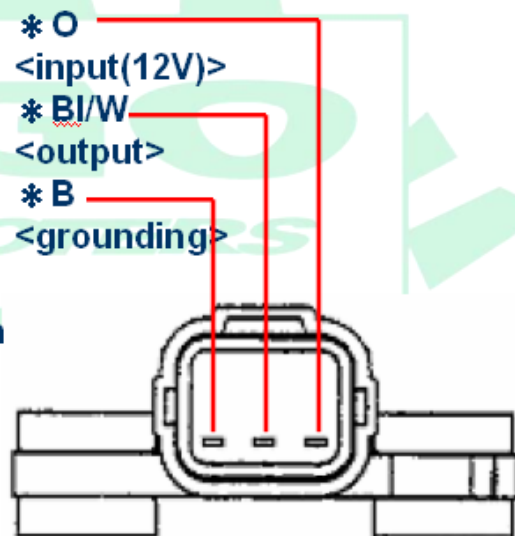

4-2.9 ISC (Idle Speed Control)

* Location

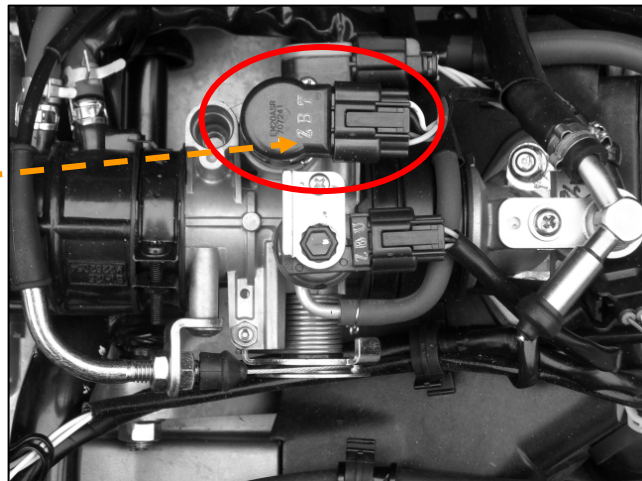
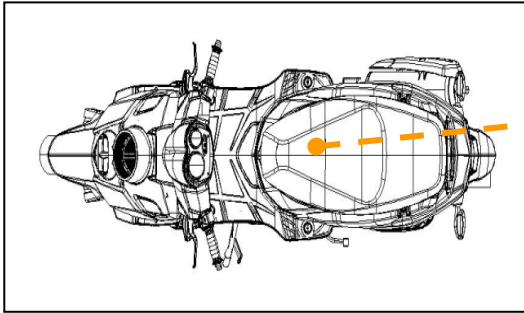

◆ ISC control method

When the engine at idle, the ECU will make reference to the other sensor signals, to calculate how much idle bypass air and Notice to the stepper motor to control the amount of bypass air volume in order to control and maintain the engine idle speed. ISC control method.

◆ Instance

When the engine is cold, it may be due to idle too low and turn off, the ECU will notify the ISC into the larger amount of bypass air. Engine fast idle operation, engine warm-up, the ECU will notify the ISC to reduce the amount of bypass air, so that the lead Engine running at a lower speed.

* ISC control schematic

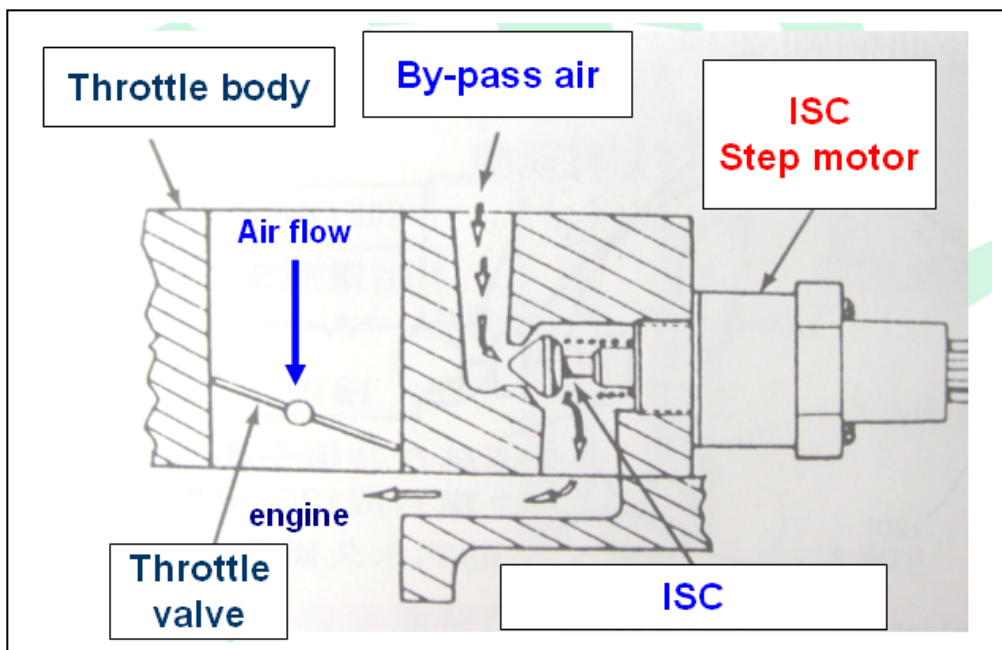

Normal idle settings : 1500rpm+100rpm

Cold idle speed increased to : 1900rpm

* ISC measurement

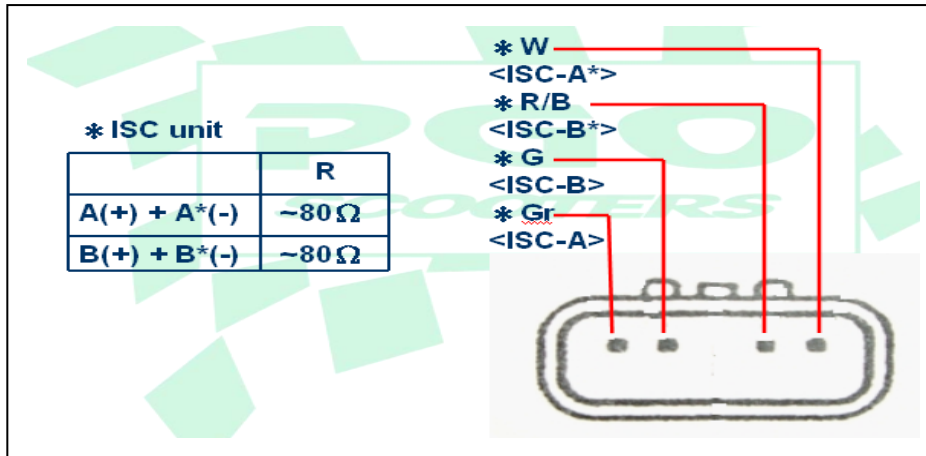

* timing when used scooter occur:

1. Hard to start the engine
2. Engine Idle speed is unstable
3. Other unstable situation

To initialize the ISC, then the ISC reset to control zero point

※ program

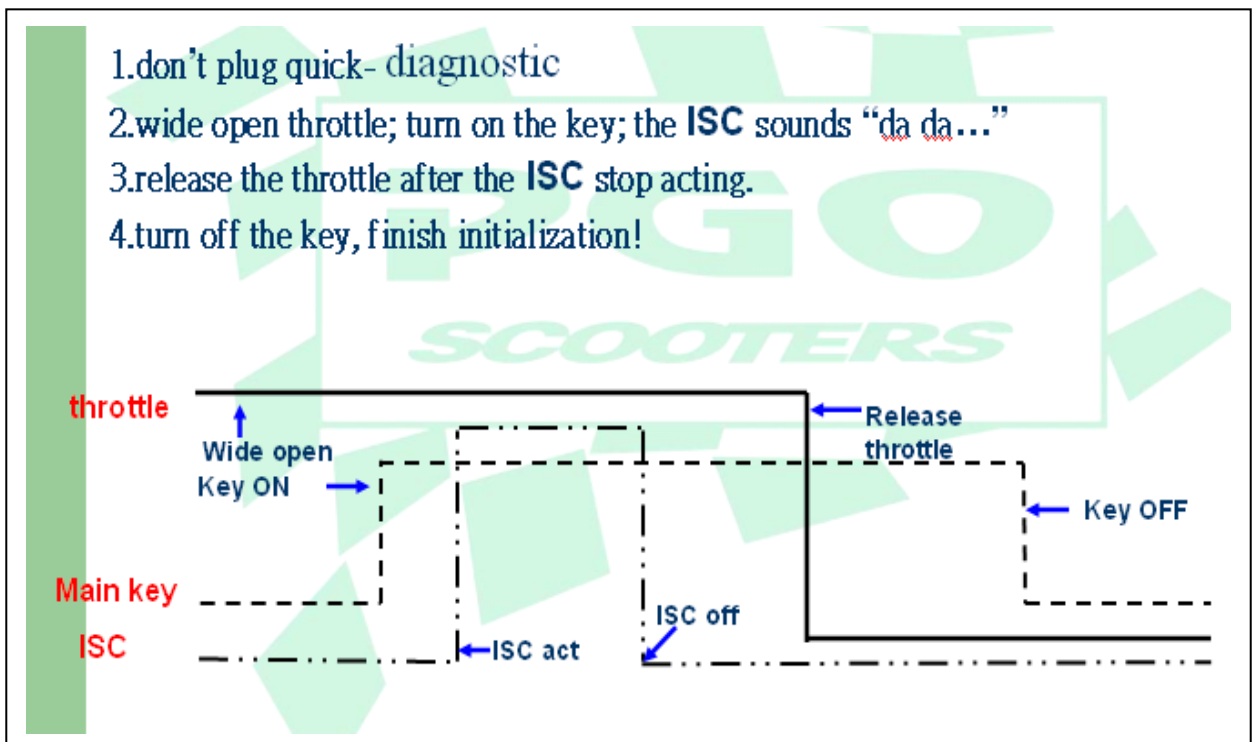

4-3 EMS system Repairing tool

* pocket tester wiring
part no. : S905310005



* Use spark gauge

* connect

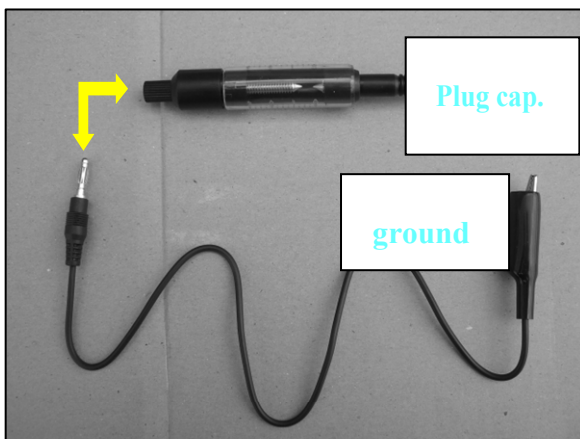

*minimum distance 6mm



Injector test line group: S905310005

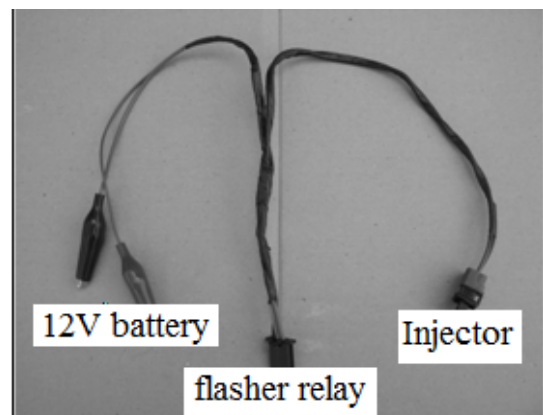

* Injector test line group use

The Injector will open with the relay Frequency of injection (recommend the use of LED Direction light relay).

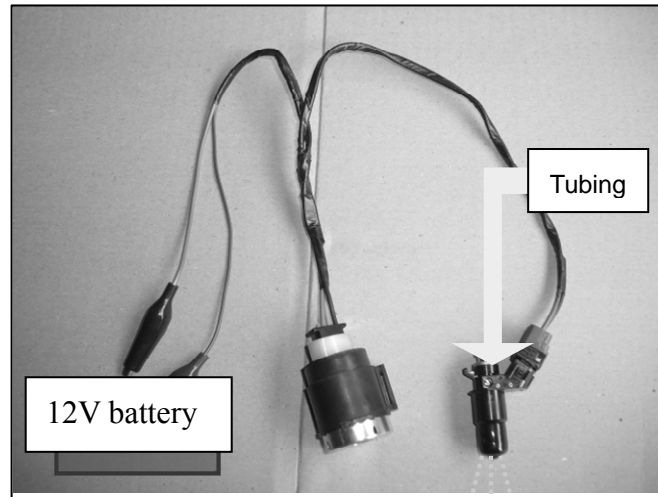

* fuel pressure gauge

part no. : S905330008



* measure the fuel

pressure

standard 3kgf/cm²

* usage

1. dismantle the hose to injector
2. connect the gauge assembly to the pipe
3. turn on the key

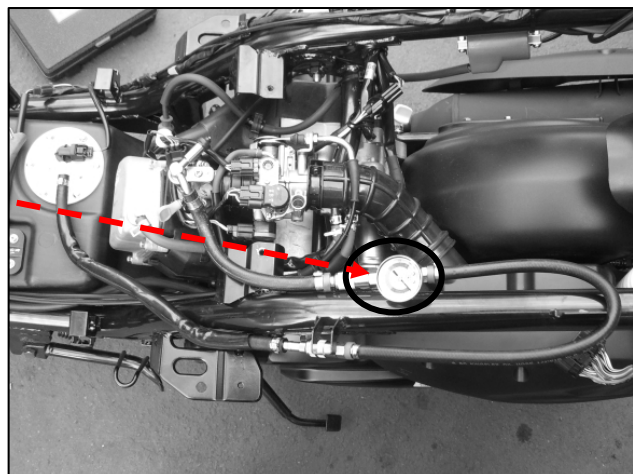

4-4 EMS diagnostic

part no. : S320840G01
 name : quick diagnostic



How to use quick diagnostic:

1. Prepare quick diagnostic
2. Open the rubber cover inside the luggage comp.
3. Plug in the quick-diagnostic
4. turn on the key
5. wait for about 8 seconds
6. observe the EMS led on dash board

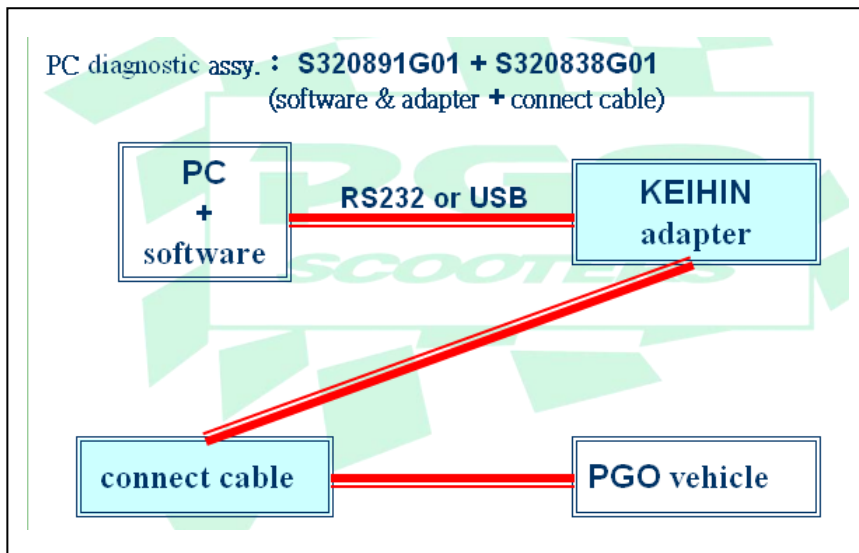
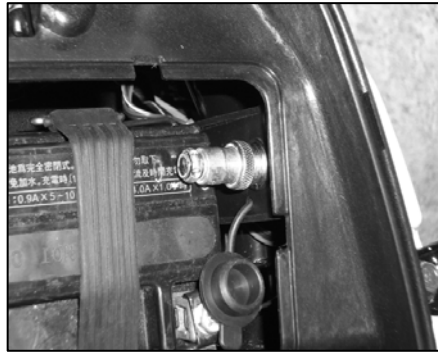

name : connect cable

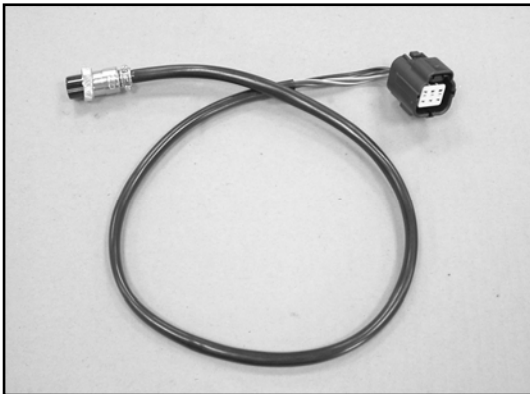

Quick diagnostic table-

part	Defect code
Throttle position sensor	0 long 6 short
Intake manifold pressure sensor	0 long 9 short
Engine temperature sensor	1 long 1 short
injector	3 long 3 short
Ignition coil	3 long 7 short
Fuel pump	4 long 1 short
Heater of oxygen sensor	4 long 5 short
ISC motor	4 long 9 short
Crankshaft position sensor	6 long 6 short
ECU	Always on
System is all right!	Always off

Clear the defect code memory:

1. plug quick diagnostic into vehicle seat
2. wide open the throttle, turn on the key
3. after the EMS led off, release the throttle
4. don't turn off the key until EMS led on again.
5. turn on the key to confirm again.

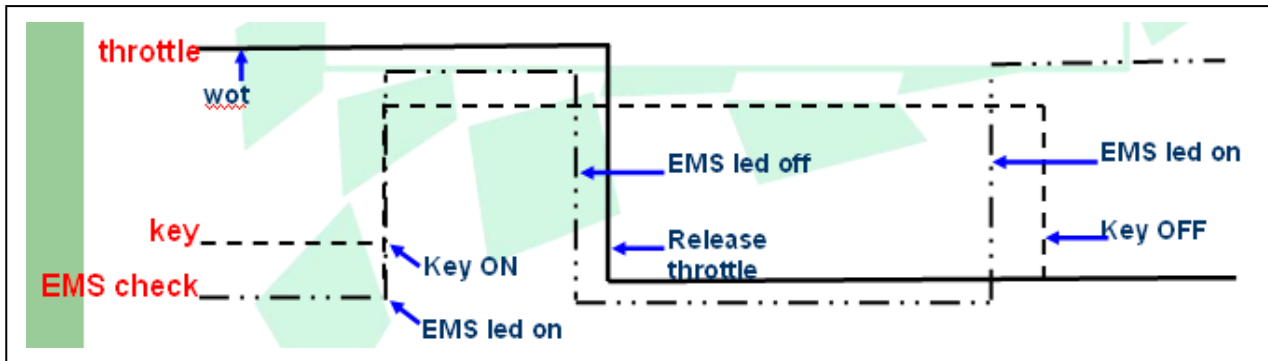

5-1 Disassembly of the engine assembly

Removing the steps:

一. Back luggage

1. Remove the screws (2), take out the Back luggage

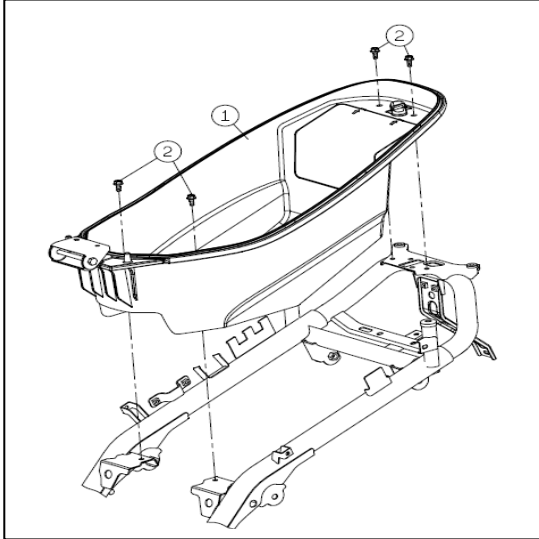

二. Muffler

1. Remove the nut / screw / washer (26/28/29/30), take out the Muffler (31) and packing (25)

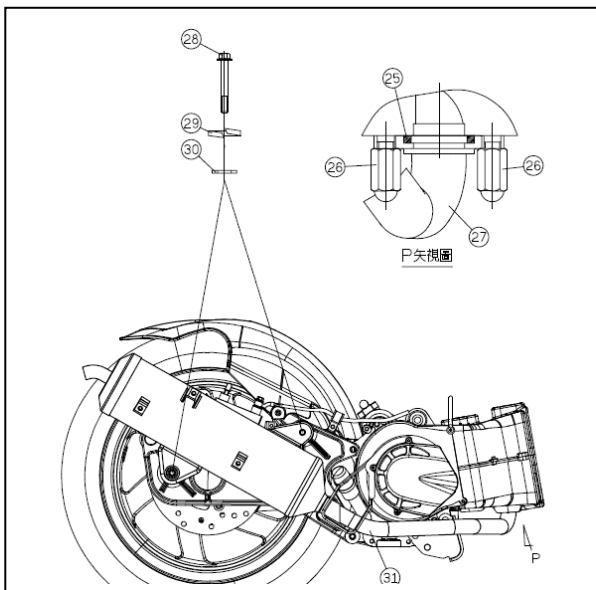

Engine / Reverse differential gear -5

三. Rear brake calipers

1. Remove the screw (19/23), take out the rear brake calipers and brake hose clamp .

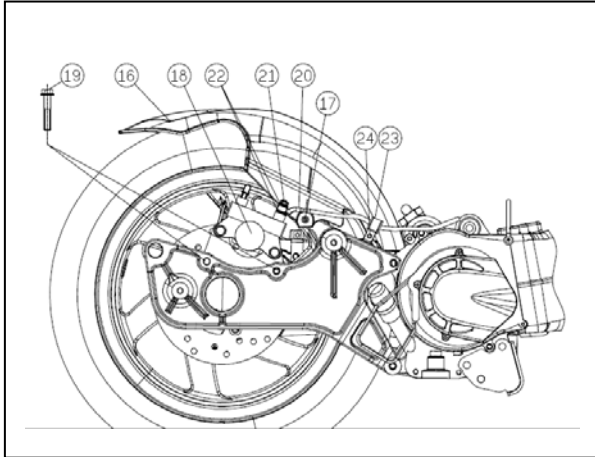

四. Remove the air cleaner

1. Remove the "EEC TUBE" and "PCV TUBE" .
2. Turn loose clip .
3. Remove the air cleaner screws 、 Washer (3/4/5) .

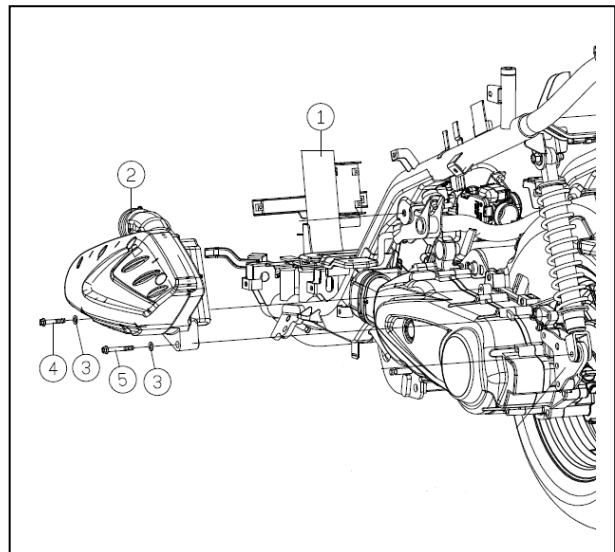
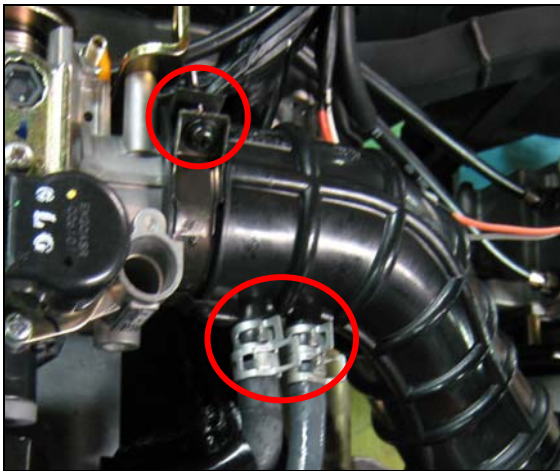

Engine / Reverse differential gear -5

五. Remove the temperature sensor 、 O2 sensor 、 Starter motor 、 A.C.G 、 Starter motor lion wiring terminals °

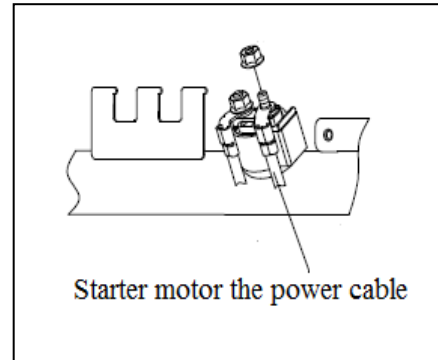
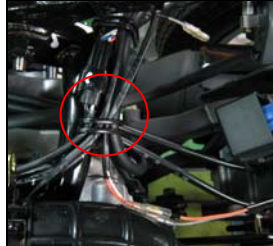

六. Throttle assembly

Remove the throttle assembly screws * 2



七. Oil cooler hose pipe

1. Remove the screw (14), take out the Oil cooler hose pipe(1) and Aluminum Washer(13)

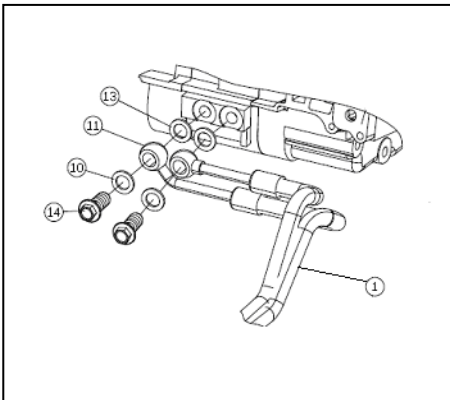

Torque values:

BRAKE HOSE JOINT BOLT: 3.0~3.5kg-m

Engine / Reverse differential gear -5

八. Rear suspension

1.Remove the left and right rear suspension screws(7)

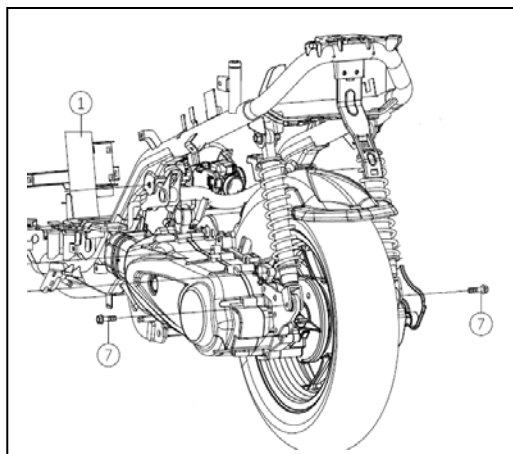

Torque values:

REAR SUSPENSION (upper):4.7-5.5kg-m

REAR SUSPENSION (under):2.0-3.0kg-m

九. Remove the engine hanger

1. Remove the engine hanger * 1 fixed nut

2. Remove the engine hanger * 1 mounting bolts

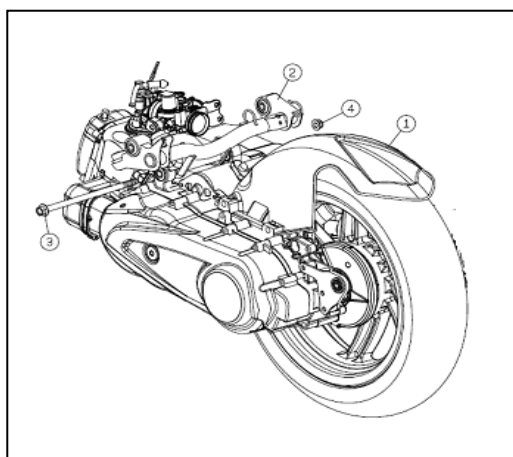

Torque values:

Engine hanger:4.0~5.0kg-m

十. Separation of the engine and the frame

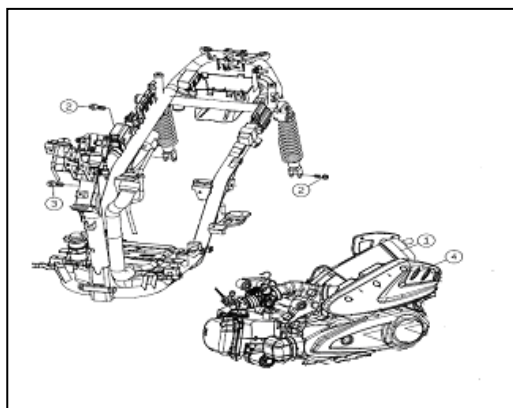

十一. Remove the reverse differential gear Steps - please refer to the reverse differential gear(Chapter 5-4)

十二. Rear Swingarm

1. Use the slotted screwdriver , remove the Rubber (10).
2. Remove the flat washer / nut (7/8/9), take out the Rear Swingarm (6).
3. Remove the screw(3) , take out the Engine lower hanger (2).

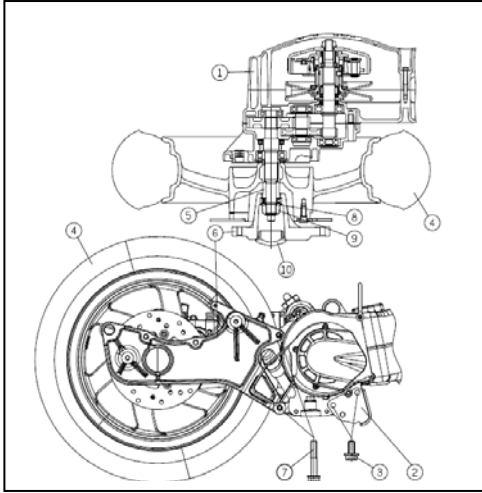

十三. Center stand

1. Remove the screw(13) , take out the SLIDE BUSH(11) · SPRING(15) · RUBBER DAMPING(14) and Center stand(12)

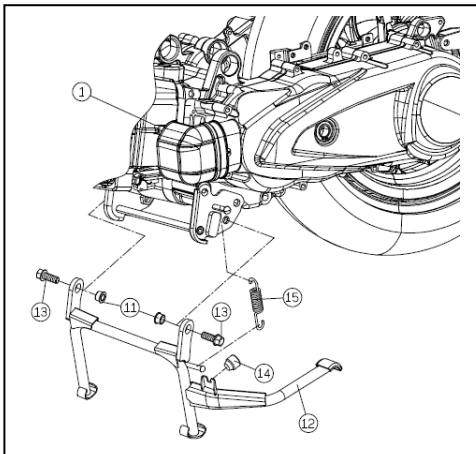

十四. Bracket rear cushion

1. Remove the screw(3) , take out the Bracket rear cushion (2)

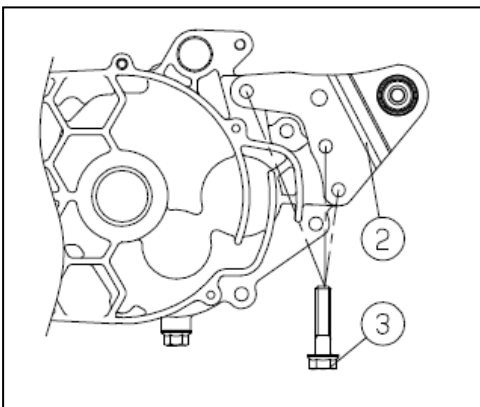

5-2 Engine disassembly

5-2.1 Cylinder head disassembly

1. Remove the screw (10/11) , take out the fan cover (8)

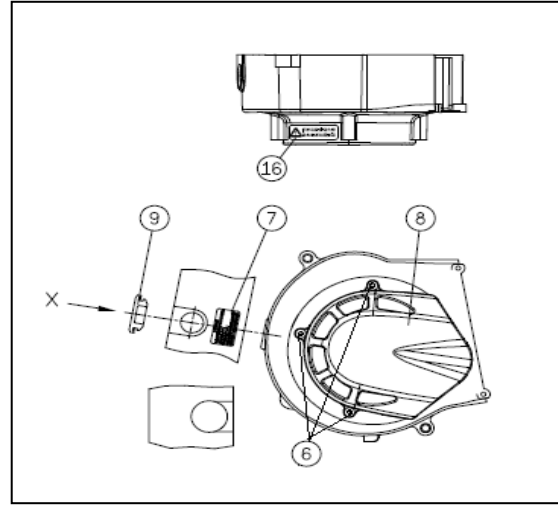
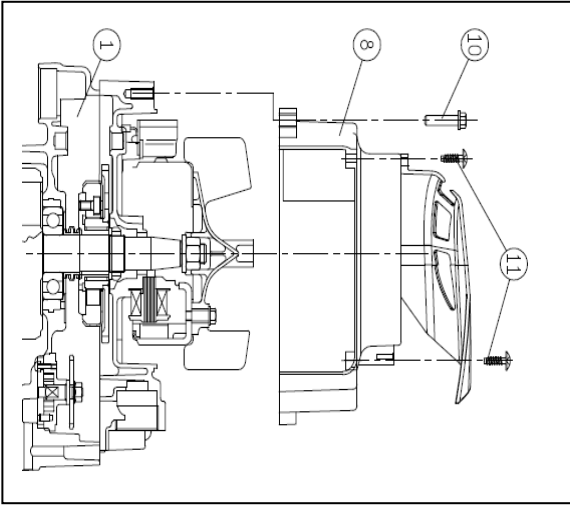

Torque values(10 、 11):0.9~1.1kg-m

2. Remove the cooling cowl (1.2) * 4 screws

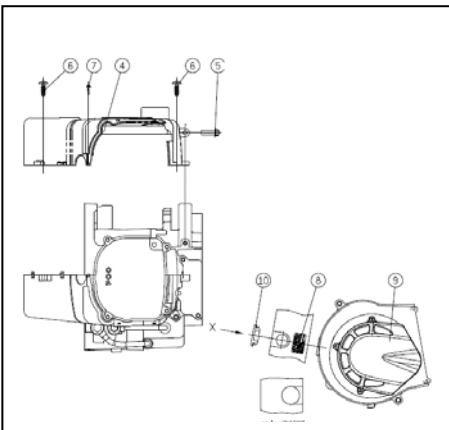

Torque values:0.9~1.1kg-m

Engine / Reverse differential gear -5

3. BF3-150 Carburettor models

Remove the bolts (5,8), removing the tube comp (7), washers (9) and the cooling cowl (1)

A. Remove the fixing screws (4), take out the separator (3).

B. Check the cylinder head gasket (5) is deformed, replace if necessary.

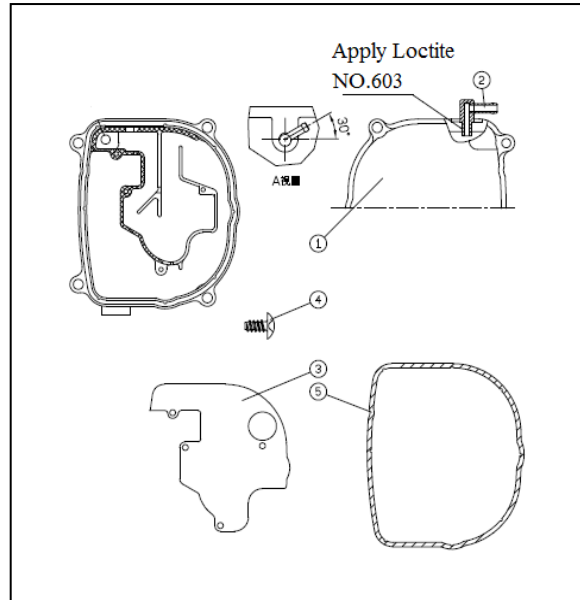
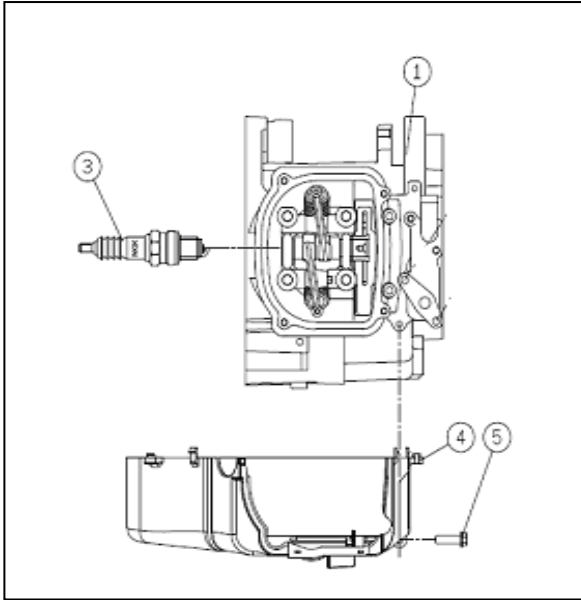

4. Remove the cylinder head cover * 4 screws

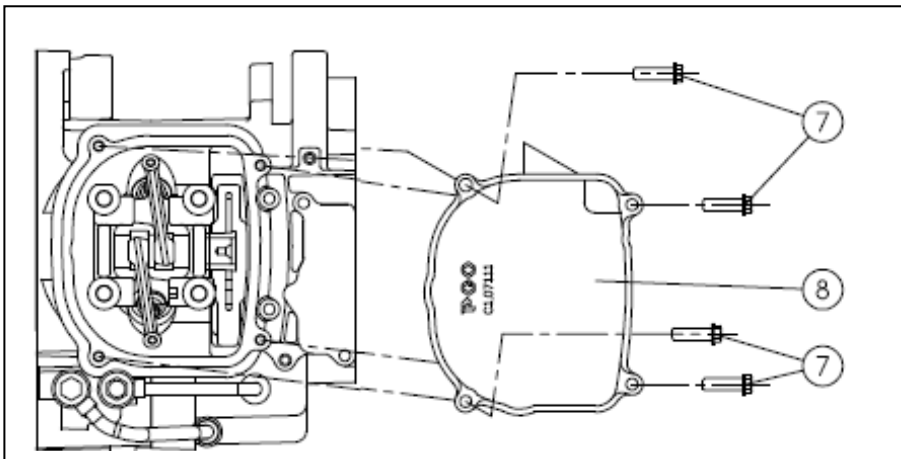

Engine / Reverse differential gear -5

5. Loosens bolts (5), remove the bolts (3) * 2

Remove the inner chain adjuster (2) and washers (4)

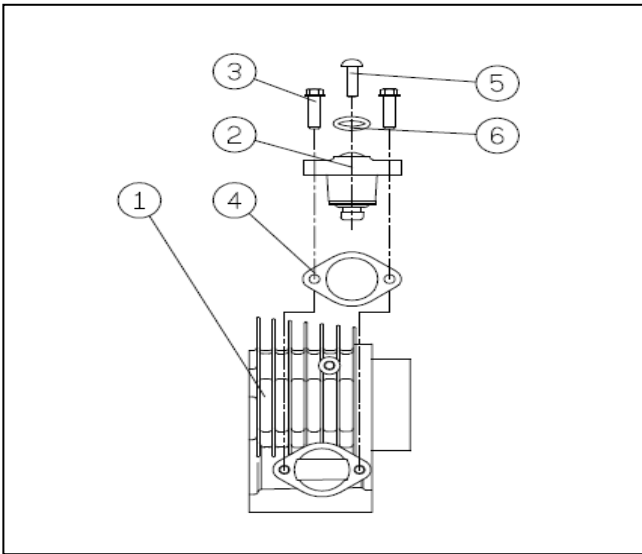

Torque values:	
Parts 3-	0.9~1.1kg-m
Parts4-	0.9kg-m

6. Remove the screws (10)

6.1 Remove the screws (12)

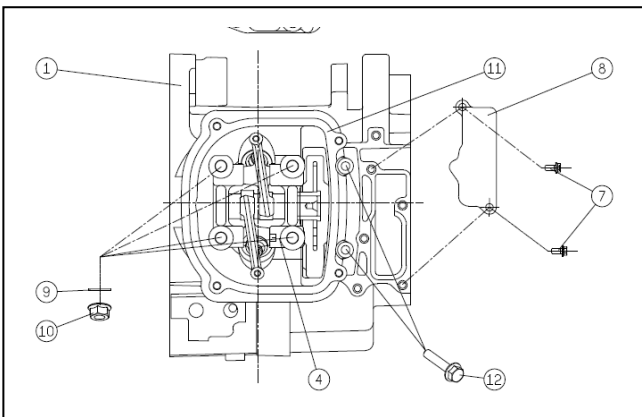

Torque values:	
Parts 9-	2.2kg-m
Parts 12-	0.9~1.1 kg-m

6.2. Remove the camshaft holder / camshaft

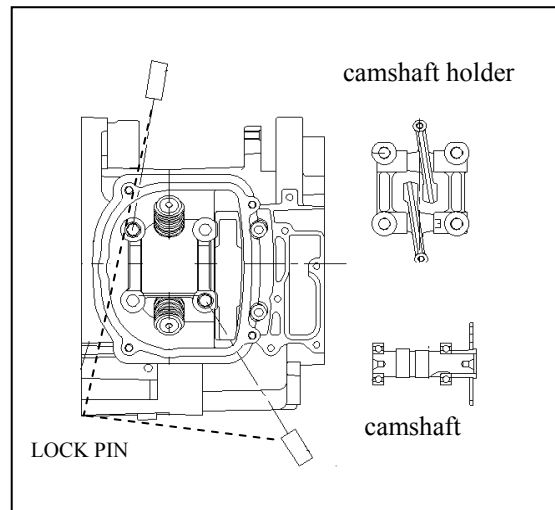

Engine / Reverse differential gear -5

7. Remove the cylinder head / cylinder head gasket

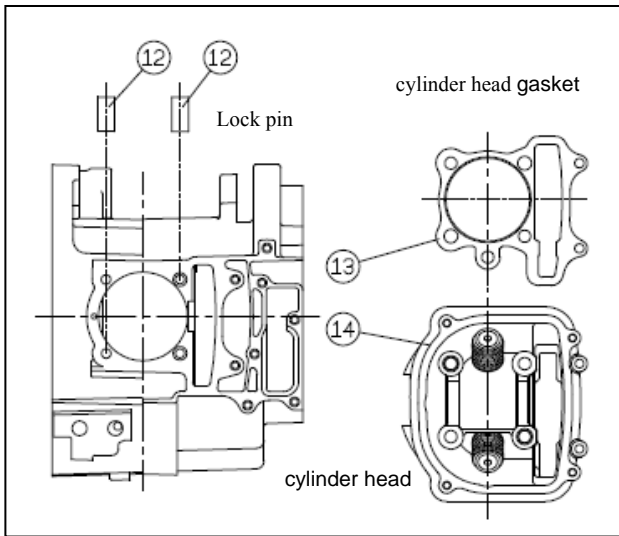

* Gaskets can not be reused

VALVE disassembly

Remove the following:

1. Use the valve compressor tool, compressed the steam valve
2. Remove the cotter valve ' Relax the valve removal tool ' The order to remove the valve spring retainer , valve spring, flain washer, seals valve.



⊙ use valve oil seals needle nose pliers folder.

Cylinder head installation steps:

Installed in accordance with the removal procedure in reverse. Please note that the timing should not be installed wrong cylinder head installation.

Engine / Reverse differential gear -5

Removing the camshaft holder:

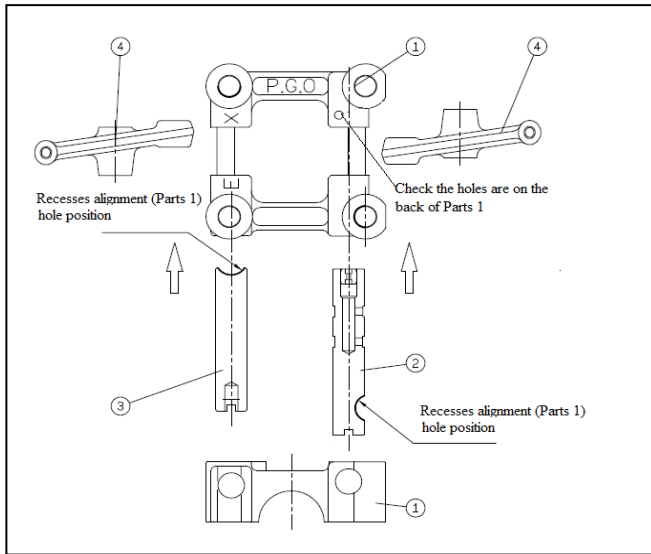

Disassembly:

1. Use 5mm screws, remove the valve rocker shaft .
2. Remove (intake and exhaust) valve rocker.

Cylinder head - timing adjustment:

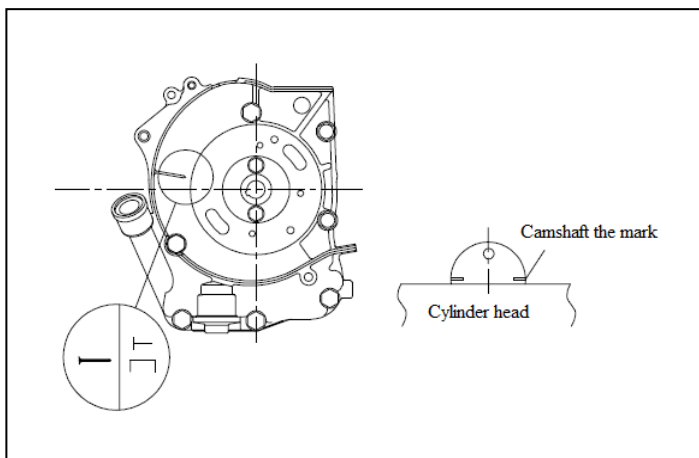

1. clockwise rotation of the flywheel to the flywheel of the "T" mark on the ° The prospective the crankcase on the instructions ribs.
2. Confirm the large hole on the camshaft at the same time appear in the vertex, and another two small hole (or horizontal line) and parallel to the cylinder head, and at that point the compression top dead point, can be performed to confirm and adjust the valve clearance.

5-2.2 Cylinder removal procedure

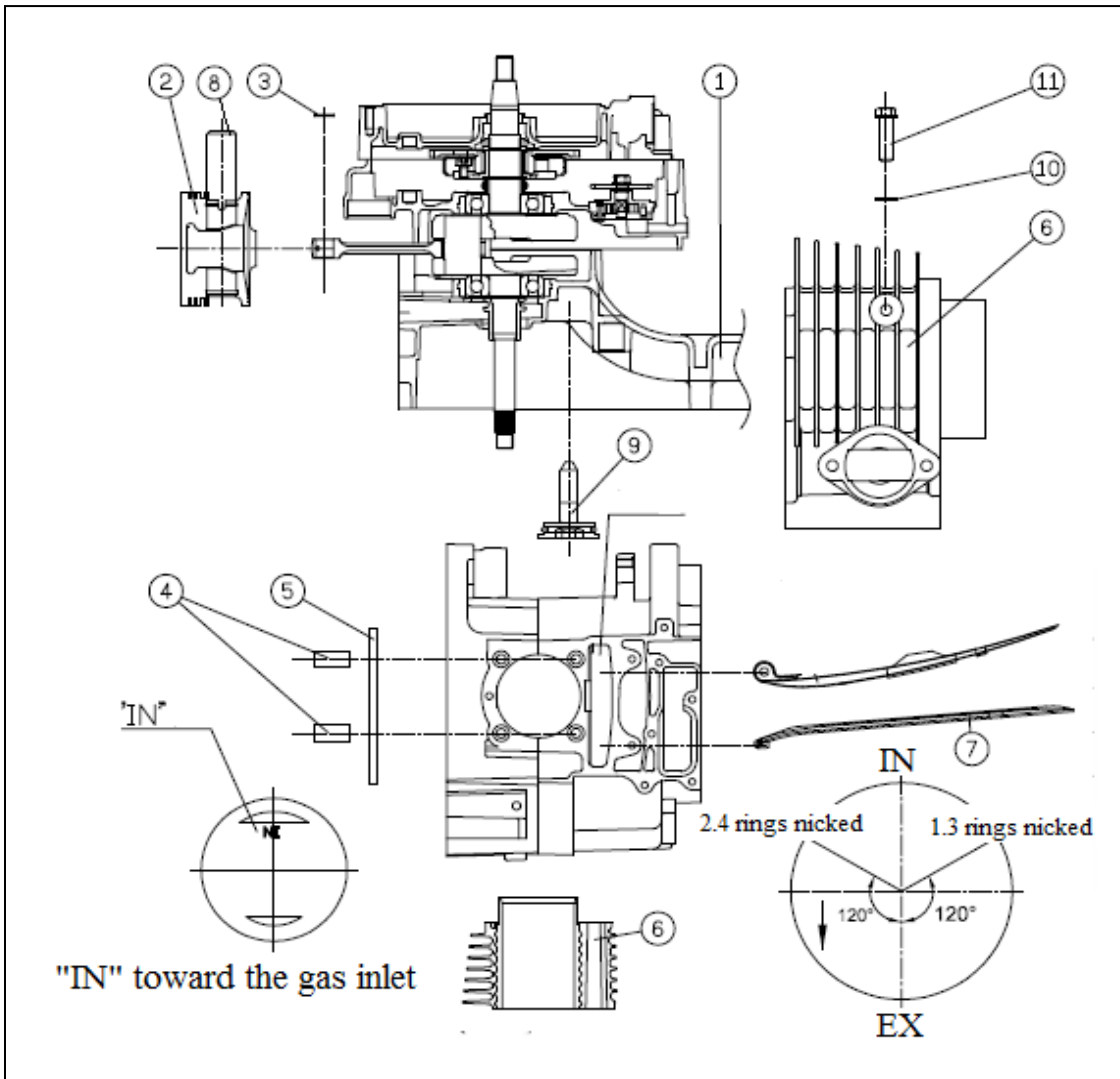

1. Remove the chain guide member (7).
2. Remove the cylinder (6) and washers (5).
3. Using needle-nose pliers to remove C-type retaining ring (3).
4. Remove the piston pin (8), the piston (2) and the positioning pin (4).

Piston rings demolition:

Use the left and right hand thumb piston ring openings distraction, the order to remove the piston rings.

Note: When removing not allow piston rings broken or damaged.



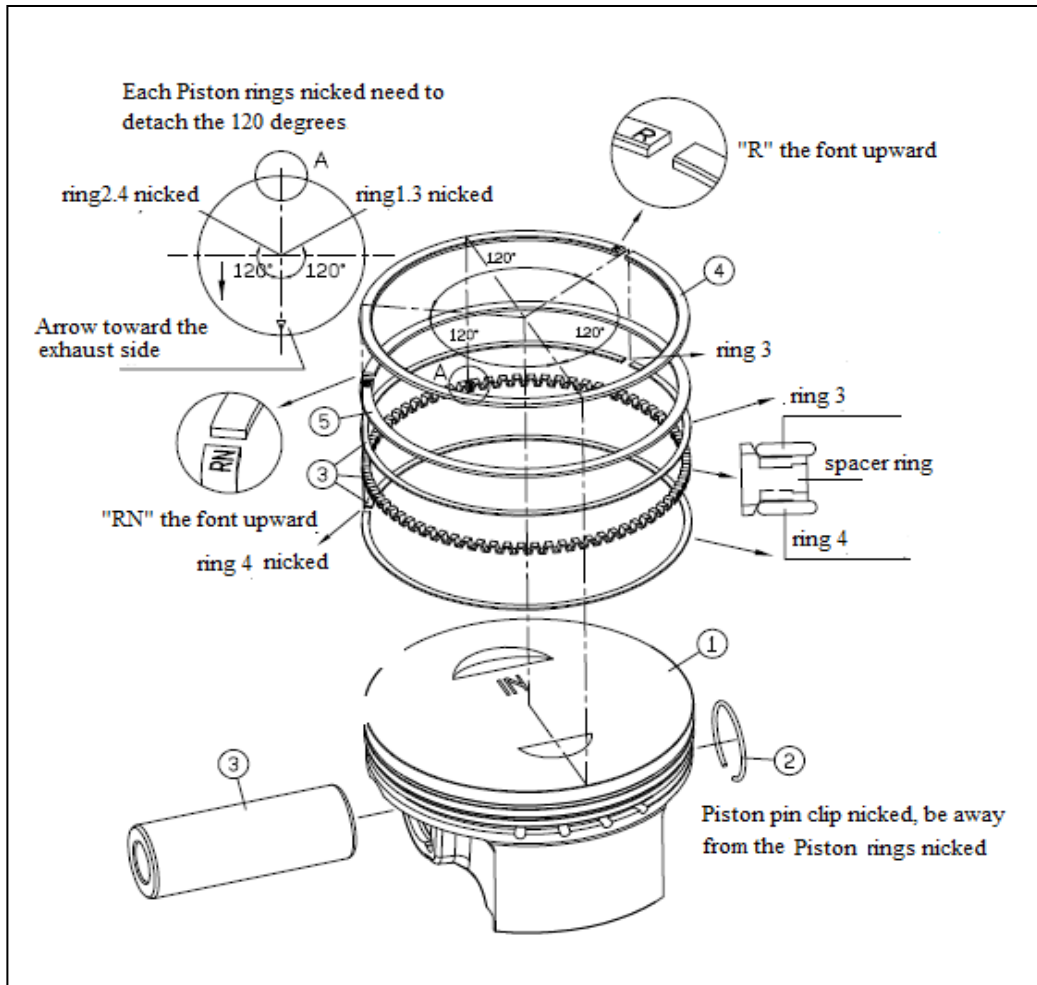

Piston ring installation:

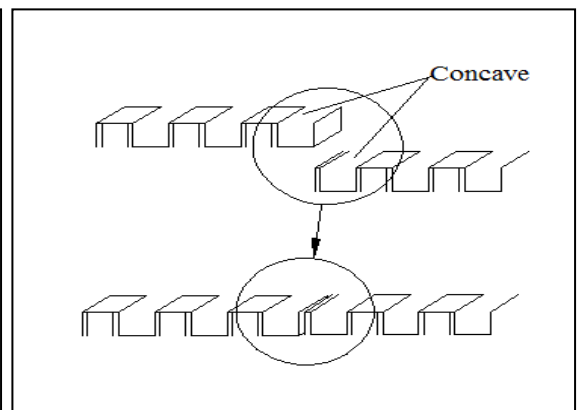
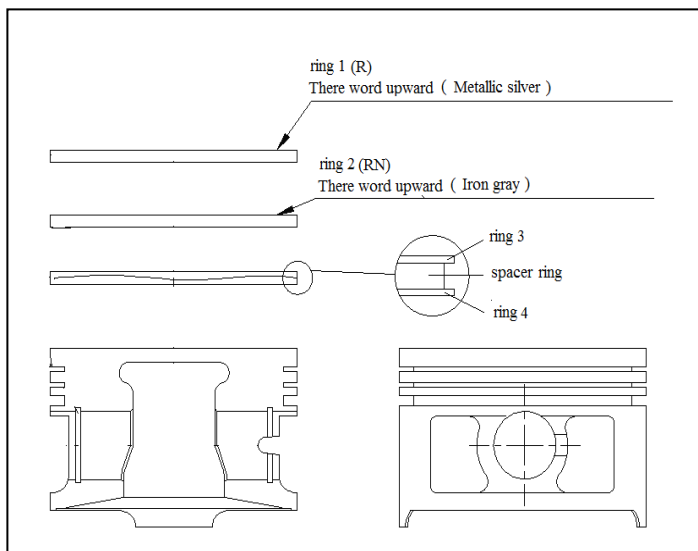

★ Install oil scraper ring - spacer ring joints shall be concave upward.

1. Install the oil scraper ring - spacer ring, ring 3 and 4 of the ring.
2. Side upward install piston rings (2) - iron gray.
3. Side upward install the piston ring (1) - Metallic Silver.
4. Piston ring can rotate freely in the piston groove.
5. When installing the piston can not be scratched. Piston ring shall not be broken or damaged.

Engine / Reverse differential gear -5

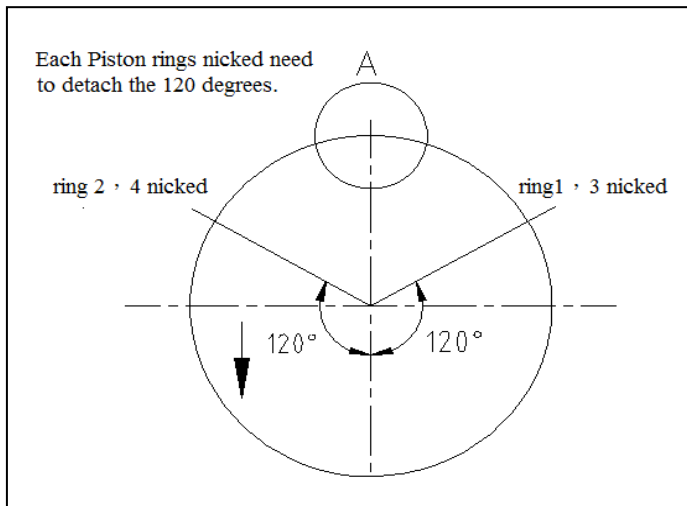

1. Each Piston rings nicked need to detach the 120 degrees.
2. Piston ring nicked and the piston pin hole can not be a straight line.
3. Piston ring nicked are installed are toward the top of the piston.
4. Notch between the rings can not overlap and must be spaced ° Upper-left 1.3 nicked, upper-right section 2.4 nicked.

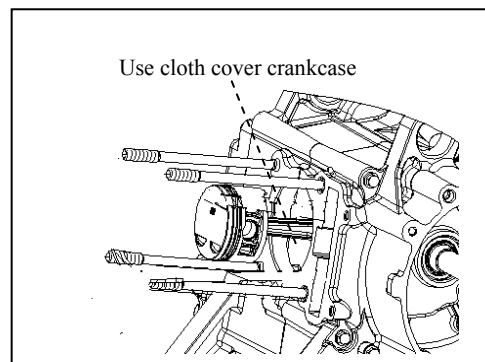
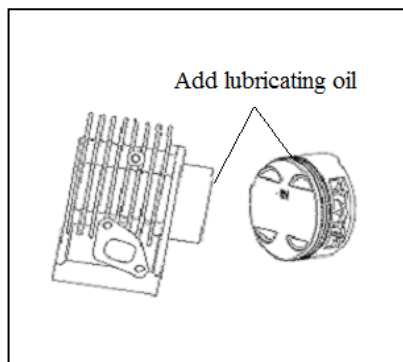

Cylinder installation steps:

Installed in accordance with the removal procedure in reverse.

Installation Notes:

1. Before installation cylinder surfaces, piston rings painted oil.
2. piston rings can not be broken or damaged.
3. not to allow the piston pin clip or foreign objects falling in the crankcase ,Cloth can be used to cover the crankcase.
4. Installed before connecting the cylinder piston
coke to clear a clean, Re-assembled.
5. The top of the piston "IN" mark on the top of the intake valve side to install.

5-2.3 CVT removal procedure

1. Remove the screws (22) and remove the left side cover (21) and retaining pin (19).

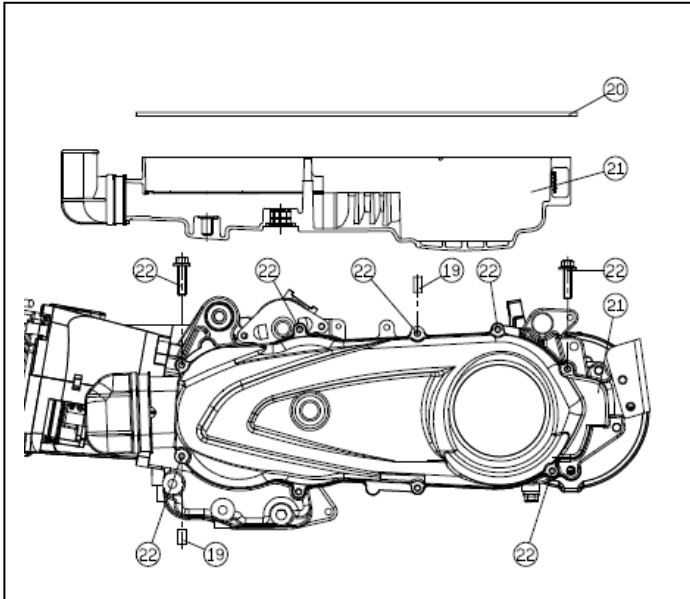

Torque values:

Parts 22- 0.9~1.1kg-m

2. Remove the CVT parts

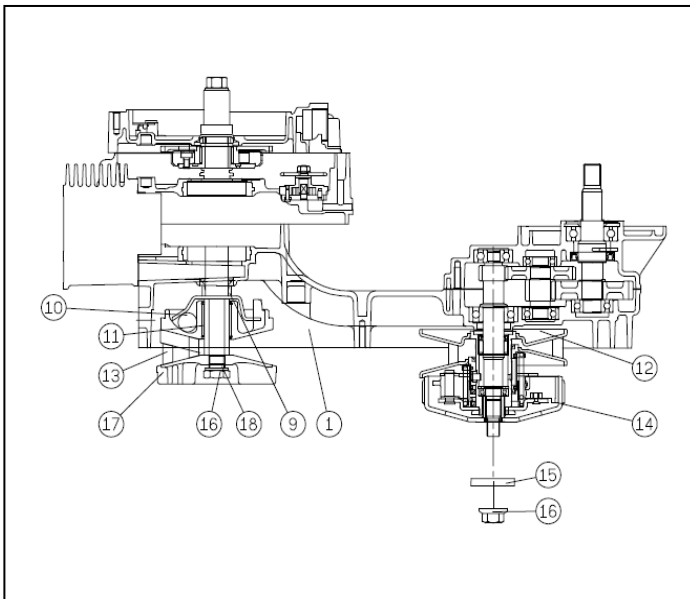

Torque values::

Parts 16- 5.0~6.0kg-m

Remove the nut (16), sequentially removed -

- A.driven face (17)
- B.face movable drive(10)and Boss drive face (11) °
- C.clutch outer body (14)
- D.driven pulley (12)
- E.V type belt (13)

CVT installation steps:

Installed in accordance with the removal procedure in reverse.

Engine / Reverse differential gear -5

Installation Notes:

Weight roller is not the same at both ends ' Please coated end is mounted on the the face movable drive trench right side ' To Weight roller life and prevent face movable drive of abnormal wear.

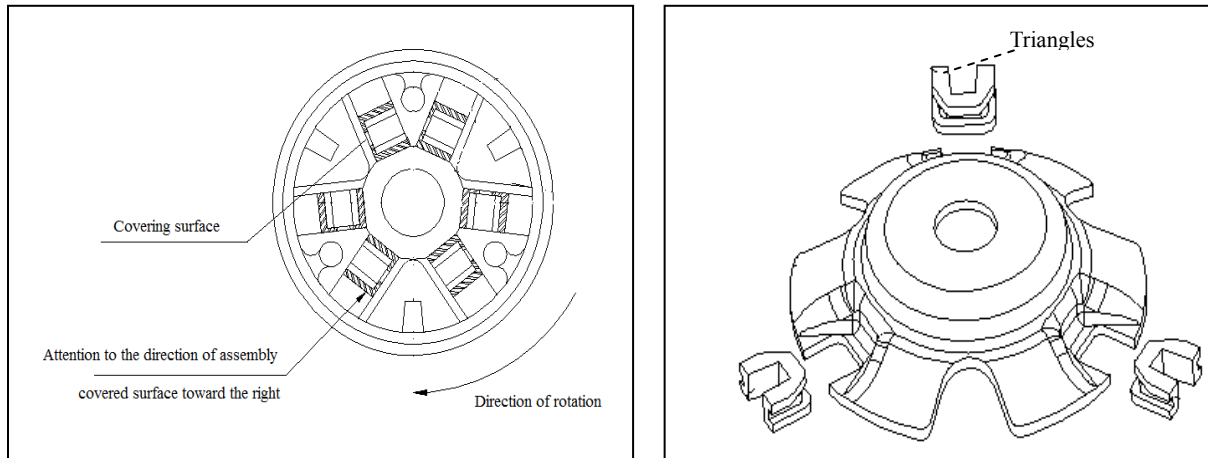

※Install the slide piece to the pump plate pressed into the triangle facing upwards.

3.belt pulley comp, driven face detachably

1.Clutch spring compression and fixed nut wrench Remove clutch fixing nut.

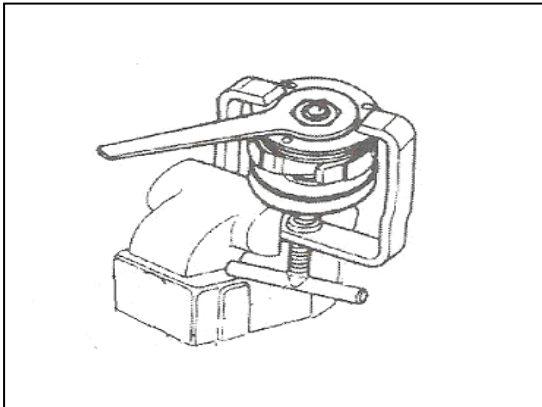

5-2.4 crankcase demolition

1. Remove the screws (1) , take out the fan(3) .

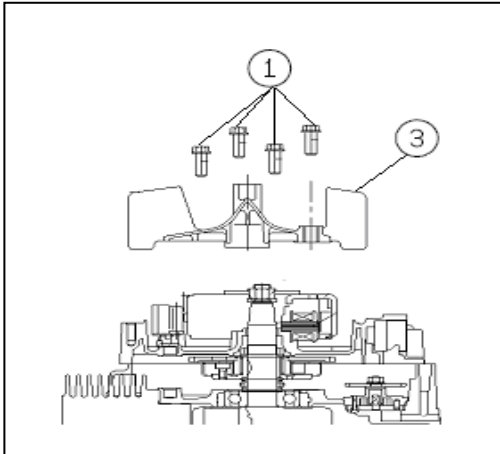

Torque values:
Parts 1: 0.9~1.1kg-m

1. Remove the screws(1) take out the flywheel (3) (electric plate puller to remove the flywheel).

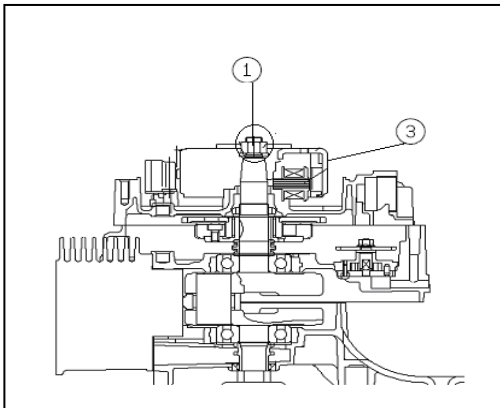

3. Remove the fixed screws(1.3) , take out the stator(4).

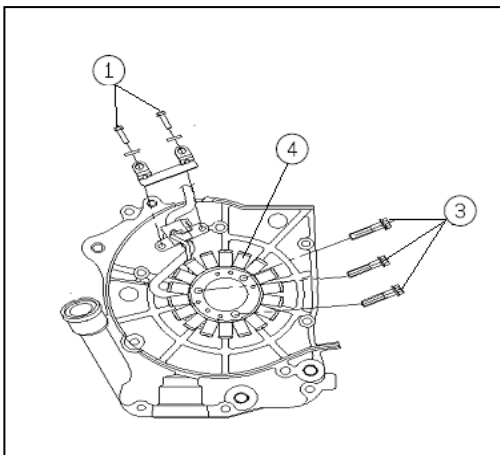

Torque: M5-0.7 ~ 0.9kg-m
M6-0.9 kg-m

Engine / Reverse differential gear -5

4. Remove the screws(15.16.17.18.19) , take out the right crankcase cover (14)

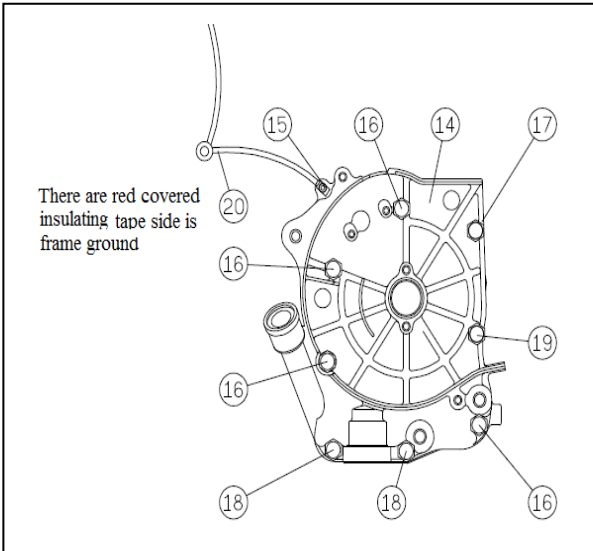

Torque:
Parts 15.16.17.18.19- 0.9~1.1kg-m

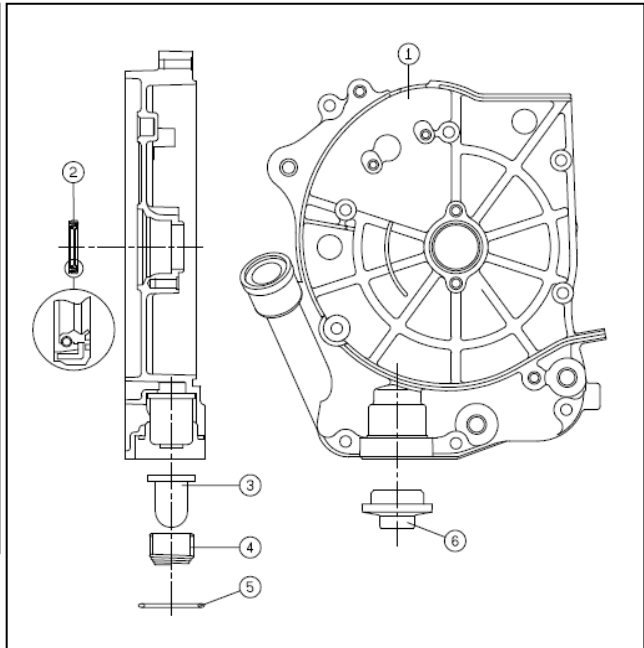

- A. Remove the oil filter cover (6) 17mm.
- B. Remove the oil strainer (3), spring (4) and O-ring (5).
- * Installation must check whether the deformation of the O-ring and replace if necessary.

5. A. Remove the right crankcase cover gasket (13).

B. Remove the starter reduction gear (10) and shaft (11).

C. Using a one-way clutch nut removal tool, remove the lock nut(9) and washers (8) , takeout the one-way clutch.

D. Remove the lock pins (12).

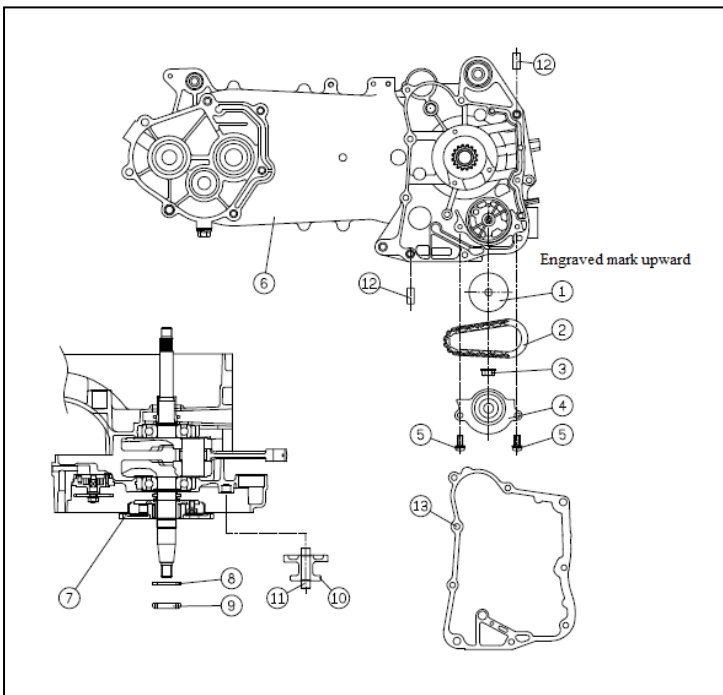

Torque:
Parts 9- 9.0~10.0kg-m

Engine / Reverse differential gear -5

6. A. Remove the screws(5), take out the oil separator(4).

B. Remove the screws(3), take out the sprkt oil pump drive (1) and oil pump drive chain(2).

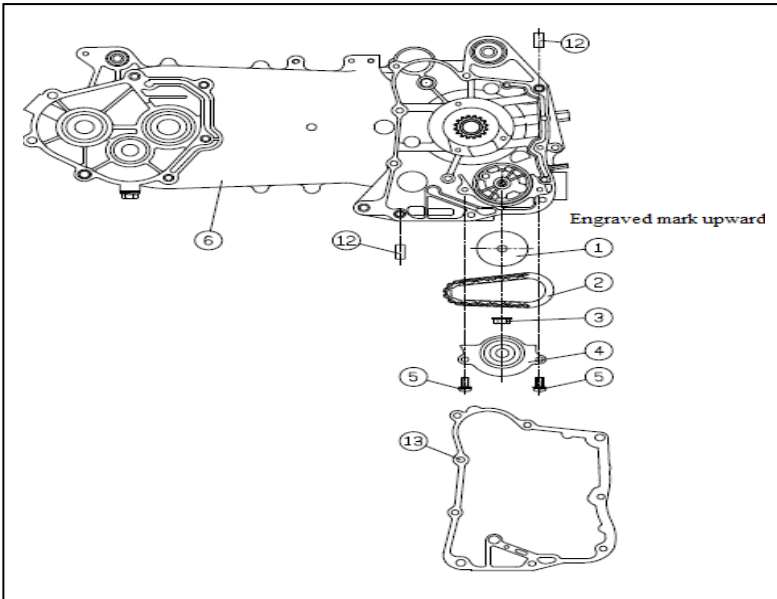

Torque:

Parts 3、5-

0.9~1.1kg-m

7. A. Remove the bolts (17), take out the oil pump (16).

B.Remove the screws (13, 15), take out the right crankcase (14).

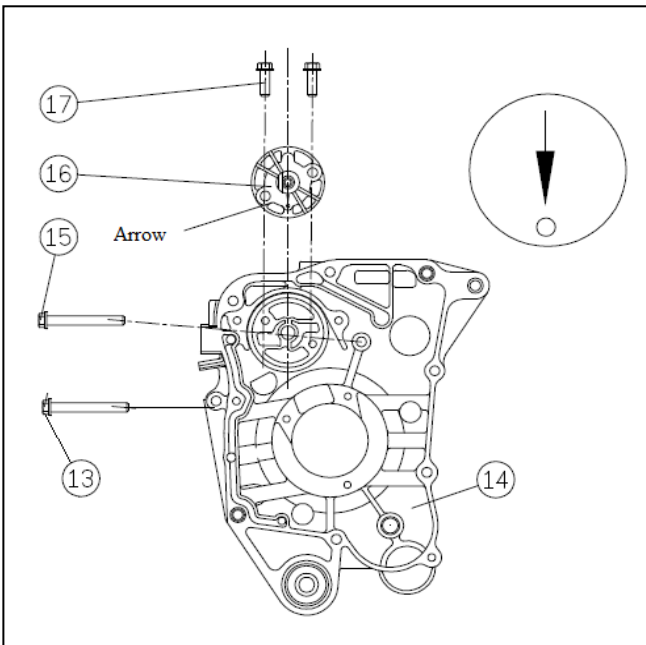

Torque:

Parts 13、15、17-

0.9~1.1kg-m

※When installing oil pump, oil pump on the arrow toward the crank shaft hole.

Engine / Reverse differential gear -5

8. Remove the right crankcase cover.

Remove the Crankcase gasket (13) 、 crankshaft (11) 、 chain camshaft (10) 、 lock pin(12).

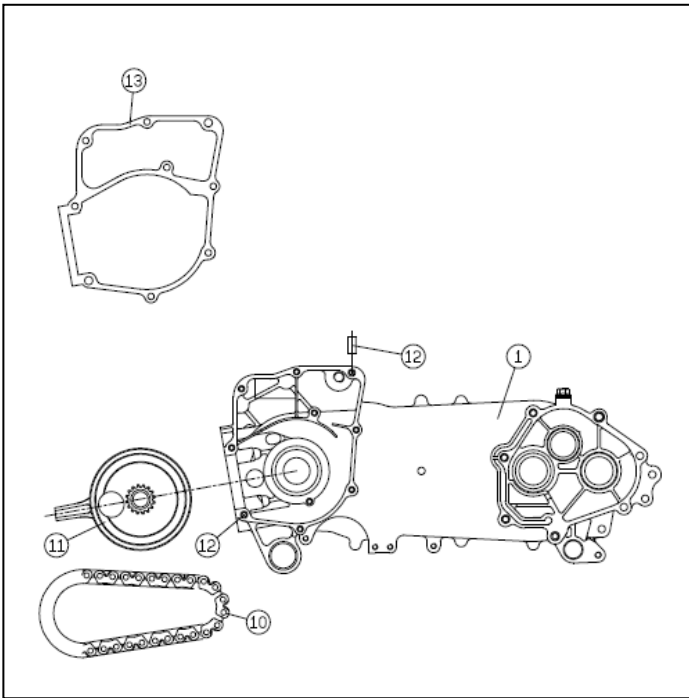

Engine / Reverse differential gear -5

1. Checking driving belt

(1) check driving belt is cracked or not rubber and fiber is loosened or not also check if they are extraordinary worn out.

(2) driving belt width:

limit of use: change it below 19mm

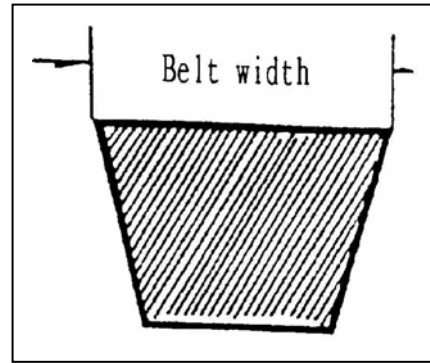

2. Disassemble slide driving plate set.

(1) Remove bush of slide driving plate.

(2) Remove screw, and disassemble the cover of slide driving Plate.

(3) Remove ramp plate.

(4) Remove weight roller.

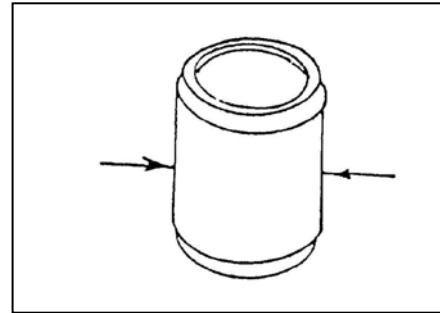

3. Check long

(1) Check the wearing condition of weight roller.

limit of use : change it

below 17.4mm

(2) Check gasket inner dia of slide driving plate:

limit of use : change it over 24.1mm.

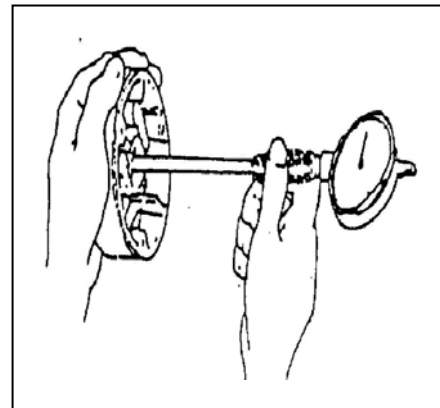

(3) Check the driving pulley:

surface wearing condition.

(4) Check the outer diameter of the contact surface of the :
movable driving plate.

limit of use : change it

below 23.94mm.

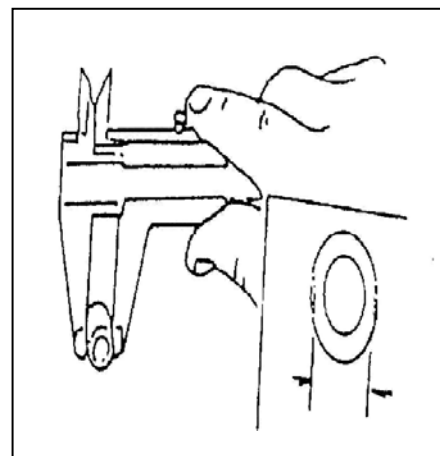

Engine / Reverse differential gear -5

4. Checking clutch:

dismantling tool

a. Check clutch driving face.

Check clutch cover about its wearing condition

And inner diameter measurement.

limit of use: change it above 125.5mm

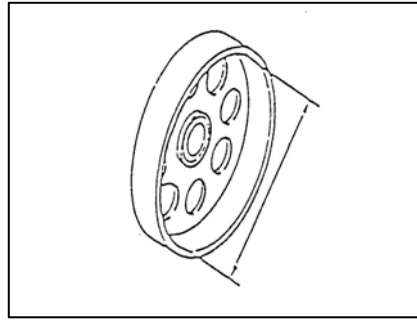

b. Check clutch lining wearing condition and measure the lining thickness.

limit of use : change it below 1.5mm.

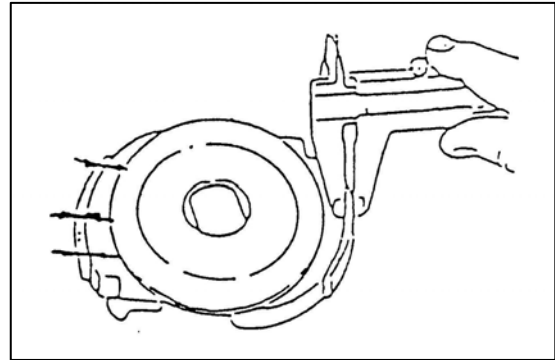

c. Check driving spring free length.

Standard: 151mm

limit of usage:

Change it below 127 mm

d. Check wearing condition of

driving plate sets. And measure outer diameter.

limit of use: change it above 33.95mm.

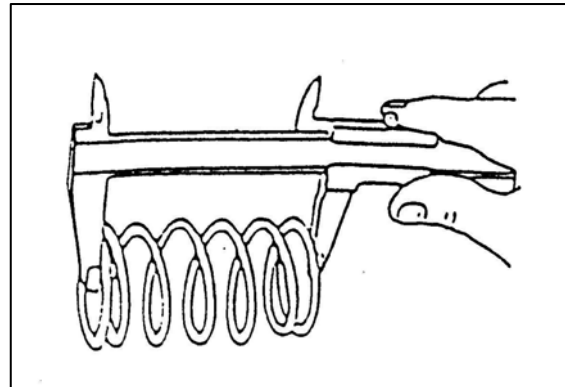

e. Check wearing condition of slide driven plate and measure its Inner diameter.

limit of use : change it above 34.00mm.

f. Check is there any wearing occur to the ditch

g. Check wearing condition of oil seal, if necessary, change a new one.

NOTE:

1. General version of the CVT system, follow the standard normal maintenance operations.
2. Cargo version of the CVT system, each regular maintenance, the implementation of simple checks (short road test) , check the clutch without severe wobble or abnormal sound? Roller without serious wear? V-belt is aging cracking?
3. In mind when installing drive belt, drive face, clutch outer, can not have grease adhesions.

5-3.2 Cylinder head and valve

A.Trouble shooting

B.The operation data information

A.Troubleshooting.

If the cylinder head is malfunctioned, usually it can tell from the measurement of the compression pressure or from the noise that comes from the upper part of the engine.

1.Unsmooth idle speed

-Compression pressure is too low.

2.Insufficient compression pressure

-Poor adjustment of valve clearance

-Valve being burned out or bent

-Valve timing is not correct

-Valve spring is damaged.

-Poor sealing of valve base.

-Leakage in Cylinder head gasket.

-Cylinder head twisted or cracked.

-Spark plug is not properly installed.

5.Abnormal noise

-Poor adjustment of valve clearance

-Valve burned or damaged spring

-Camshaft is worn out.

-Chain adjuster is worn out.

-Camshaft, valve rocker arm is worn out.

3.Compression pressure is too high

-There is too much carbon accumulated in the combustion chamber.

4.There is white fume coming out from the exhaust pipe

-The valve stem or valve guide pipe is worn out.

-Valve stem's oil seal is damaged.

B. The operation data information (BF3-168)

Description	IN/EX	Standard Value (mm)	Limit of use (mm)
Clearance between adjuster tapped Screw and valve stem (Before warm up)	IN	0.08	—
	EX	0.08	—
Compression pressure(throttle open full)		11kg/650rpm	
Height of the cam's convex part	IN	26.625	26.23
	EX	26.53	26.13
Inner diameter of rocker arm shaft	IN	10.00~10.015	10.10
	EX	10.00~10.015	10.10
Outer diameter of rocker arm shaft	IN	9.972~9.987	9.91
	EX	9.972~9.987	9.91
Valve base angle	IN&EX	1.0	1.8
Outer diameter of valve stem	IN	4.975~4.900	4.90
	EX	4.955~4.970	4.90
Inner diameter of valve guide	IN	5.000~5.012	5.30
	EX	5.000~5.012	5.30
Clearance between valve stem and Valve guide	IN	0.010~0.037	0.08
	EX	0.030~0.057	0.10

Check cam shaft

Check the convex surface and the height and see whether it has been damaged.

Limit of Use:
 IN: replace it below 26.23mm
 Ex: replace it below 26.13mm



Check camshaft. If the bearing is loosen or worn out, change the whole set if necessary.

Check cam shaft holder

1. Check the cam shaft holder, cam rocker arm, and cam Rocker arm shaft and see whether it is loosen or worn out.

NOTICE:
 Do check if there is any damage on the cam rocker arm Sliding surface.

2. Cam shaft holder and cam rocker arm outer diameasurement:

Limit of use : replace it above 10.10mm.

3. Cam rocker arm inner diameasurement:

Limit of use : replace it above 10.10mm.

4. Cam rocker arm shaft and rocker arm outer diameasurement:

Limit of use : replace it below 9.91mm.

5. Clearance between the Cam rocker arm and rocker arm shaft.

Limit of use : replace it above 0.10mm.

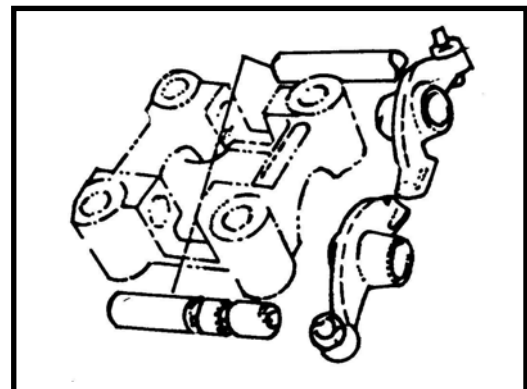

Engine / Reverse differential gear -5

WHEN INSTALLING:

A. The mark "EX" on the cam shaft holder is the exhaust rocker arm, one-way stopper.

Install the exhaust rocker arm, the inlet rocker arm, and the rocket arm shaft.

NOTICE:

- a. The tangen angle of the heat side of intake valve's rocker arm shaft is to match with the bolt of the cam holder.
- b. The tangent angle of the exhaust valve's rocker arm shaft is to match with the bolt of the cam holder.

B. Turn the flywheel to make the T mark pin correctly. The hole on the cam chain gear should point upwards. Both the left and right concave points and the cylinder head are at parallel position (convex part of cam shaft points upwards), then install the cam shaft on the cylinder head.

C. Install the cam chain onto the cam shaft gear.

D. Install the locking pin.

E. Install the camshaft holder, washer and nuts on the cylinder head.

6. Lock tightly the cylinder head nuts.

Locking torque: Cam shaft holder nuts: 2.0kg-m

NOTICE:

- a. Put some grease on the bolt thread of cam shaft holder
- b. Lock the nuts of the cam shaft bracket in "cross" sequence for 2-3 times.

7. Adjust the valves clearance.

5-3.3 Lubrication System

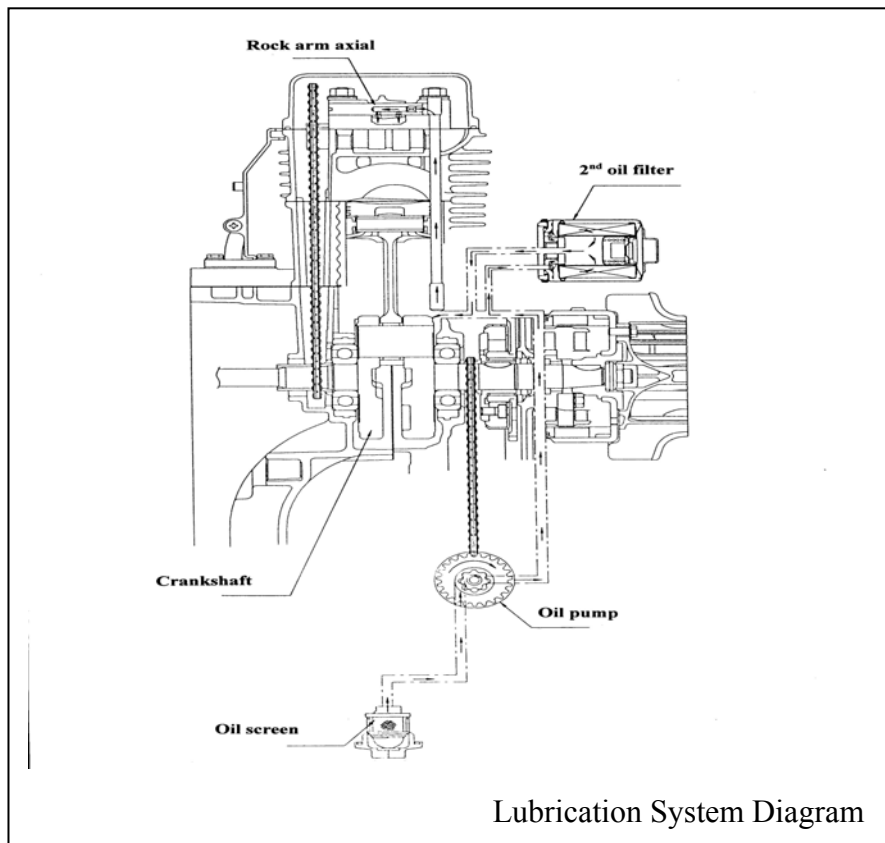

Assembly:

1. Install the inner and outer of the oil pump.
2. Install the oil pump shaft.

Note:
The notch of the oil pump shaft should comply
With the notch of the inner gear.

3. Install the lock pin.
4. Match the lock pin hole to the pump cover and install the oil pump cover.
5. Put on the screws and tighten them.
6. After installing, turn the shaft lightly to assure installation.
7. Place the oil pump into the crankcase.

Note:
When installing, the arrow on the oil pump
body should be pointed upwards. Then fill in
the recommended oil before the installation.

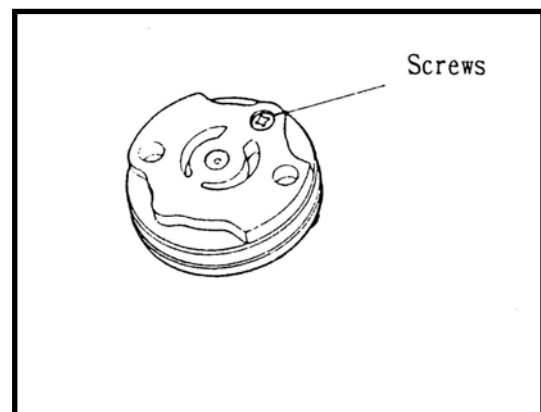
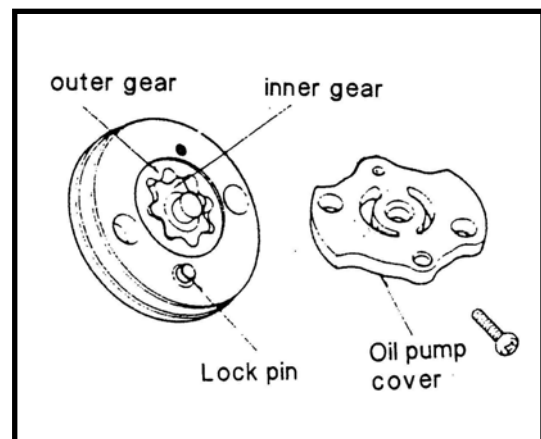

Engine / Reverse differential gear -5

8.Tighten the oil pump after installation.

Troubleshooting:

Reduction in fuel oil volume

Engine burning-out

a.Natural consumption

a.Zero or too low oil pressure

b Leakage of fuel

b.Blockage in oil route

c.Piston loop seizes, or improperly install-ation

c.Did not use the fuel oil recommended

d.Worn out of valve's oil seal

Measurement data (Hooligan 170i)

item		Standard Value (mm)	Limit of use (mm)
Oil pump	Clearance between the inner gear And outer gear	-	0.12
	Clearance between the outer gear And oil pump body	0.045-0.10	0.12
	Clearance between gear end and Oil pump body	0.045-0.10	0.12

5-3.4 Cylinder and piston

- A. Trouble shooting
- B. The Operation notice
- C. Data
- D. Dismantling cylinder, piston
- E. Installing cylinder, piston

Engine / Reverse differential gear -5

A.Troubleshooting.

- a.Compression pressure is too low, difficult to start engine and engine running unsmoothly.
 - 1.Cylinder head gasket cracked.
 - 2.Spark plug is not well locked.
 - 3.Piston ring worn out or cracked.
 - 4.Cylinder, piston worn out.
 - 5.Reed valve is out of order.
- b.Compression pressure is too high; Engine overheating; abnormal noise.
 - 1.piston tip has too much carbon accumulated.
- c.Abnormal piston noise
 - 1.Cylinder and piston worn out.
 - 2.Piston pin hole or Piston pin worn out.
 - 3.Connecting rod small end or bearing worn out.
- d.Abnormal piston or cylinder noise
 - 1.Piston ring worn out or cracked.
 - 2.Cylinder worn out or cracked.

B.The operation notice

1. Clean before operation to avoid particles dropping into the engine.
2. The contact surface of gasket must be clean.
3. Dismantle cylinder and cylinder head by screw driver. Do not injure the contact surface.
4. Cylinder inner surface and piston outer face can't be injured. Contact Surface should lubricate by specified oil.

C.Data (Hooligan 170i)

Part name /description		Standard value(mm)	Limit of use(mm)
Bore		61.000~61.010	61.10
Curve		-	0.05
Cylindrility		-	0.05
Roundness		-	0.05
Clearance b/w Piston and Piston ring	1st ring	0.02~0.06	0.10
	2nd ring	0.01~0.05	0.10
Clearance of cutting section	1st ring	0.15~0.35	0.50
	2nd ring	0.15~0.35	0.50
	side ring	0.2~0.7	0.9
Piston outer diameter		60.980~60.960	60.90
Measuring location of piston outer dia.		Down to7.5mm from the piston skirt	---
Clearance b/w piston and cylinder		0.025~0.035	0.10
Piston pin hole inner dia		15.000~15.006	15.045
Piston pin outer diameter		15.000~14.994	14.960
Clearance between piston and piston pin		0.020~0.017	0.025
Connecting rod small end inner dia		15.010~15.028	15.060

D. Dismantling cylinder, piston

a. Dismantling piston

1. Remove the piston pin clip.

NOTICE:

Don't drop the clip into the crankcase.

2. Remove the piston pin and take off the piston.

3. Check piston, piston pin, piston ring.

4. Remove the piston ring

NOTICE: NOTICE:

Don't make piston ring worn out or damaged

5. Clean the carbon in the groove of the piston ring.

b. PISTON OUTER DIA MEASUREMENT:

1. Measuring location:

Perpendicular to the piston pin hole, down to 7mm from the piston skirt.

Limit of use : change it when less than 61.0mm.

2. The clearance between the piston and piston pin:

Limit of use : change it when above 0.025mm

3. Checking any wearing, damage inside the cylinder.

Vertical to piston pin, and in X-Y direction to measure cylinder bore from the upper, middle and lower location.

Limit of use : Change it when above 61.10mm.

4. The maximum clearance between the cylinder and piston pin.

Limit of use : Change it when above 0.1mm.

5. The difference between the X and y is the roundness.

6. The cylindrility is the max value of the difference between the upper, Middle and lower position of the inner dia in X or Y direction.

Limit of use : Roundness: change it when above 0.05mm.
Cylindrility: change it when above 0.05mm.

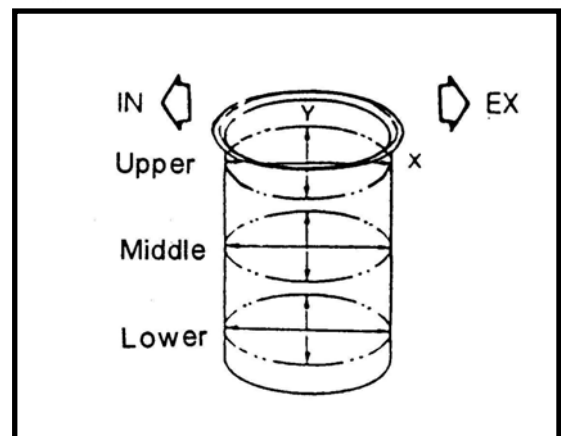
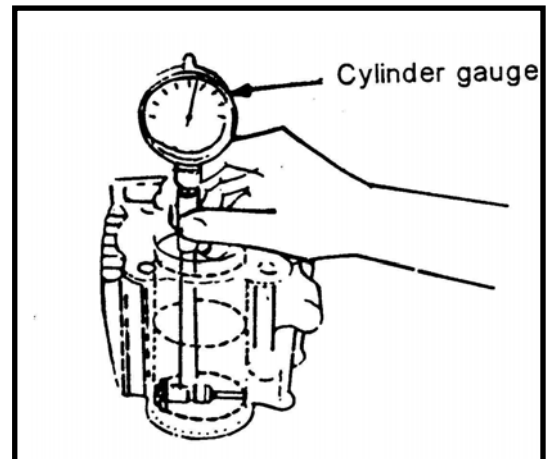
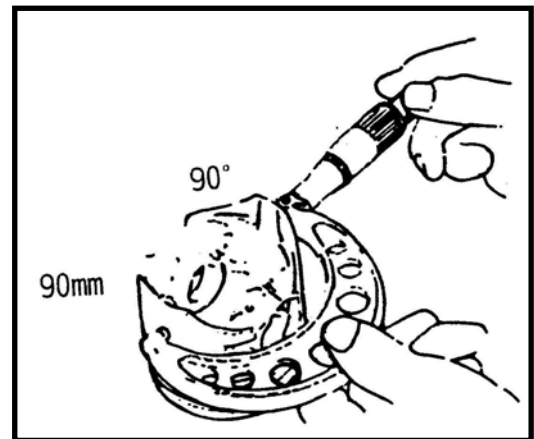

Engine / Reverse differential gear -5

c. Checking the flatness of cylinder contact surface.

Limit of use : change it when above 0.05mm.

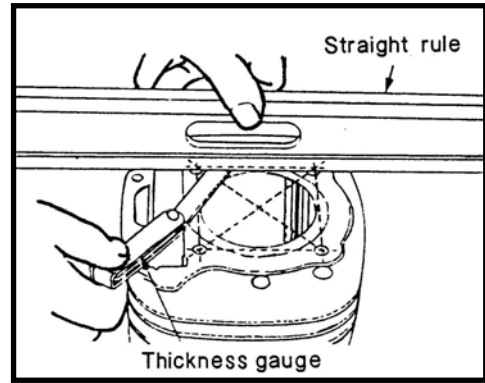

d. Connecting rod small end inner diameter measurement.

Limit of use : change a new one when above 15.060mm.

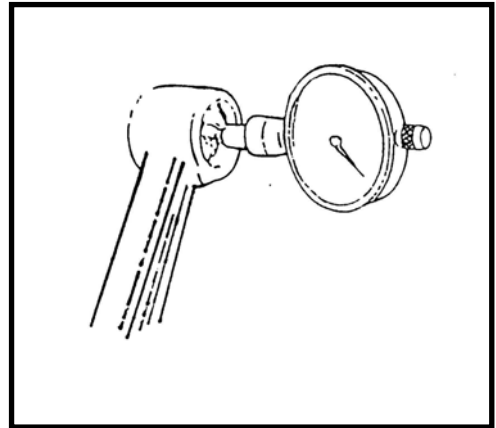

D.Installing Cylinder and piston

a.Installing piston and piston rings

- 1.Lubricate the piston rings by motor oil.

NOTICE:

- a. Be careful not to scratch the piston and not to break the piston ring.
- b.The mark (on the ring) should be upward when installing.
- c.after installing, the ring should be smoothly rotated.

- 2.Clean up the residual gasket on the crankcase.

NOTICE:

Do not drop other objects into the crankcase.

- 3.Assemble the piston, piston pin and piston pin clip.

NOTICE:

- a.The mark "IN" on the piston tip should face to the INLET side.
- b.Do not drop the piston pin clip into the crankcase and to clog the crankcase with rags.

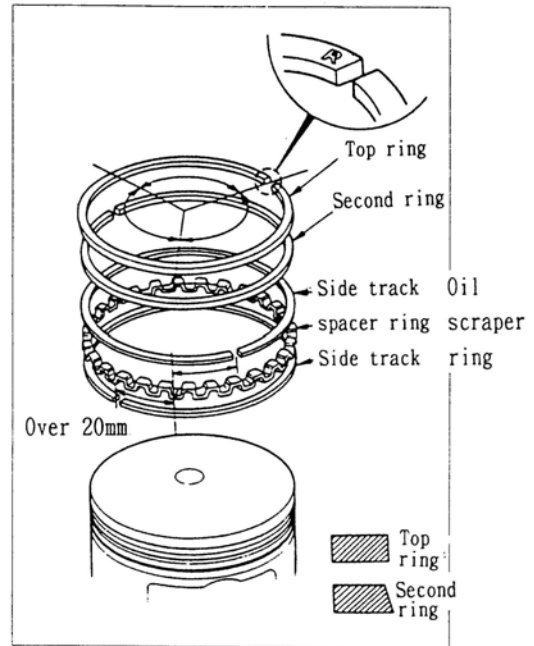

b.Installing piston

- 1.Fix the lock pin and gasket on the crankcase.
- 2.Lubricate the Cylinder inner surface, piston and piston rings by Motor Oil.
- 3.Install the piston ring into the cylinder carefully.

NOTICE:

- a.The piston ring cannot be damaged or cracked.
- b.The cutting section of three rings must be arranged at intervals of 120°

5-3.5 Crankcase, Crankshaft:

A. Troubleshooting.

B. Data

A. Troubleshooting

Engine noise:

1. The bearing of final transmission mechanism is loosen.
2. Crank pin of bearing is slack.
3. The bearing of gear box is loosen.
- 4.

B. Data (Hooligan 170i)

Item	Standard value(mm)	Limit of use.(mm)
Clearance of connecting rod big end axle direction	0.10~0.35	0.55
Clearance of connecting rod big end vertical direction.	0.006~0.014	0.04
Swingness of the crank shaft journal.	0~0.015	0.05

.Check crankshaft

1. Measure the difference of the connecting rod big end between the X and Y.

Limit of use : replace it when above 0.04mm.

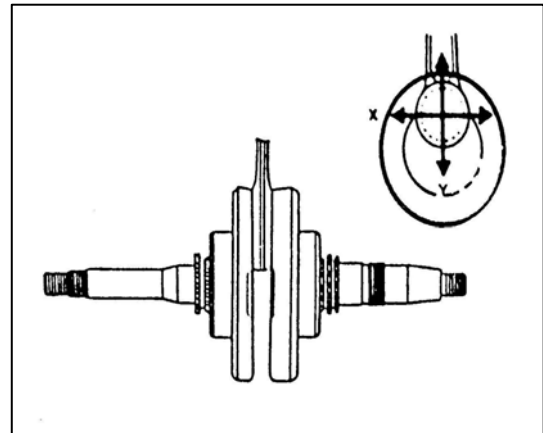

2. Measure the swing ness of the crankshaft journal.

Limit of use	
A	B
Change it when above 0.05mm	Change it when above 0.05mm

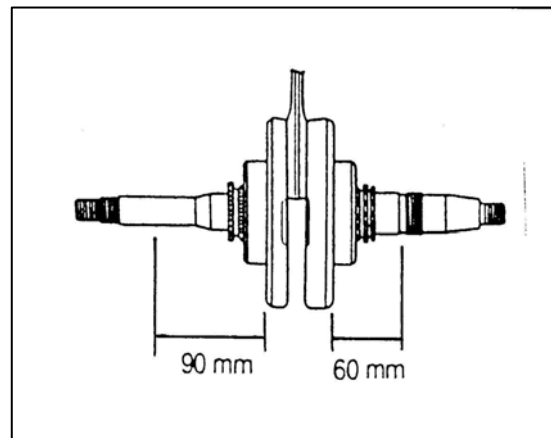

Engine / Reverse differential gear -5

1. Check the looseness of crankshaft bearing.

If it is loosen, replace to a new one.

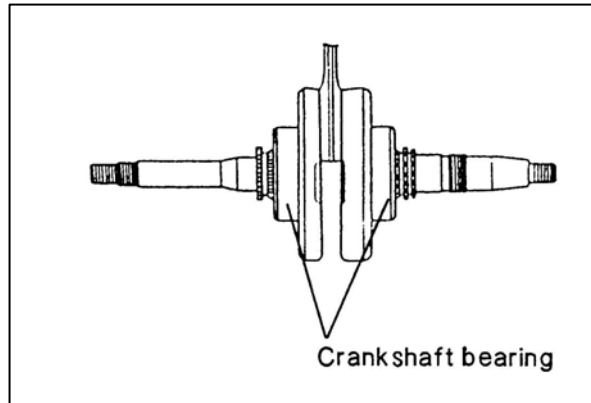

5-3.6 Final transmission mechanism

- A. Troubleshooting.
- B. Disassemble the final transmission mechanism.
- C. Check the final transmission mechanism.
- D. Assemble the final transmission mechanism.

A. Troubleshooting

- Engine can be started, but the vehicle doesn't move.
 - 1. Gear worn-out or cracked.
 - 2. Gear burnt out.
- Noise occur when running.
 - 1. Gear worn out, burnt or gear surface.
 - 2. Bearing worn out of loosen.
- Oil leakage
 - 1. Too much oil
 - 2. Seal worn out or damaged.

B. Disassemble the final transmission mechanism:

- 1. Remove the rear wheel.

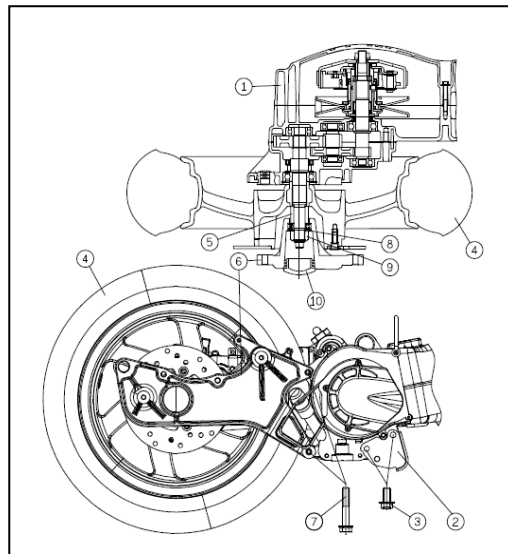

- 2. Drain the oil in the gear box.

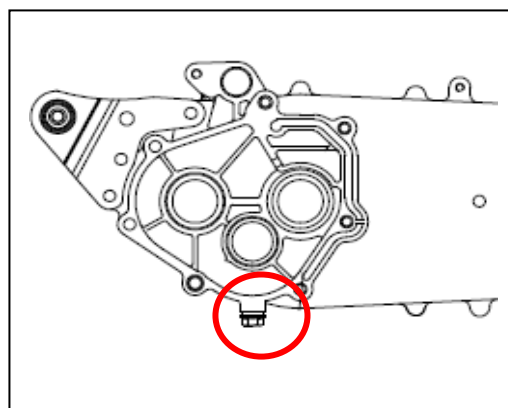

Locking torque:
M8*P1.25*12L: 1.7~2.0kg-m

Engine / Reverse differential gear -5

3. Remove the bolt(3) , take out the bracket rear cushion (2).

Locking torque:
M8*P1.25*40L: 2.0~3.0kg-m

4.Remove the bolt(4.5.6.7.8) , take off the gear box cover.

Locking torque:
Parts4:M8*P1.25*50L: 2.5~2.8kg-m
Parts5:M8*P1.25*45L: 2.5~2.8kg-m
Parts6:M8*P1.25*40L: 2.5~2.8kg-m
Parts7:M8*P1.25*30L: 2.5~2.8kg-m
Parts8:M8*P1.25*150: 2.5~2.8kg-m

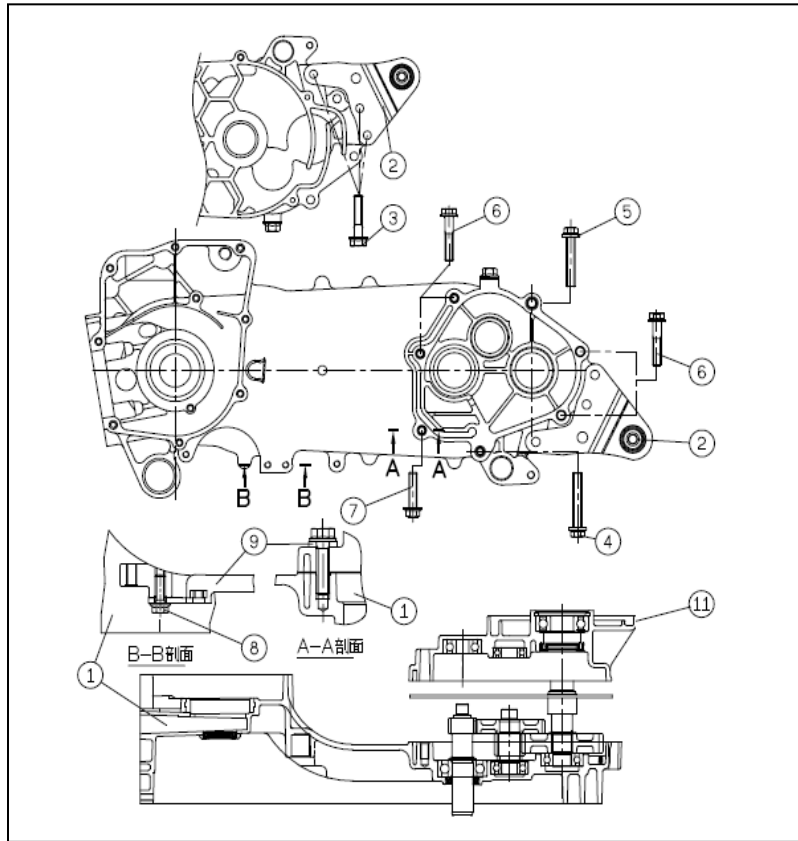

5.Remove the final reduction gear(9) , axle drive (8) , idle gear(10) and driving shaft(6).

6.Clean up the gear box.

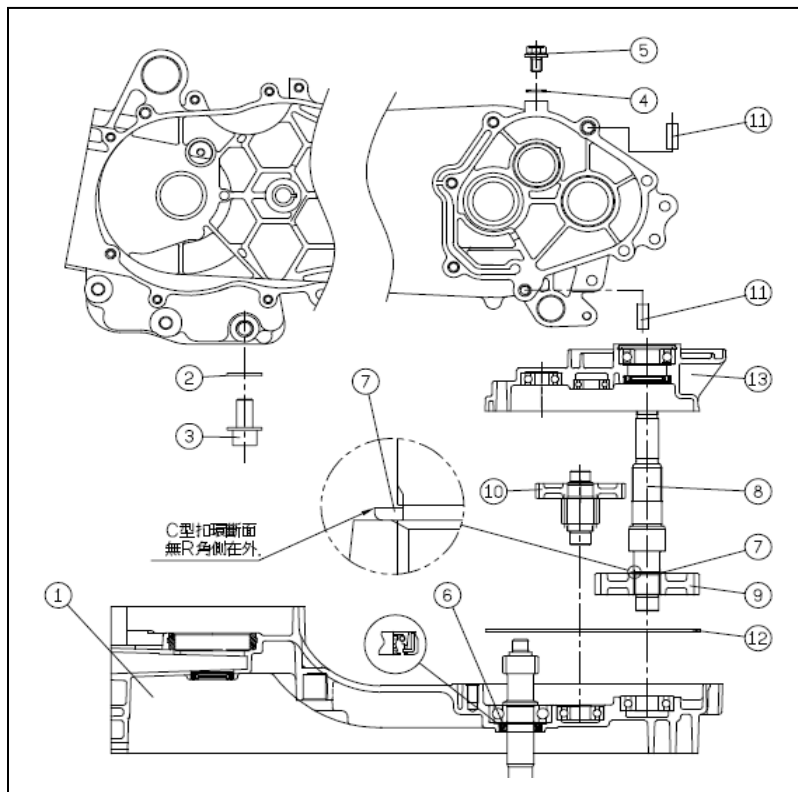

Engine / Reverse differential gear -5

C. Check the final transmission mechanism

1. Check the wearing condition of driving shaft and gears.

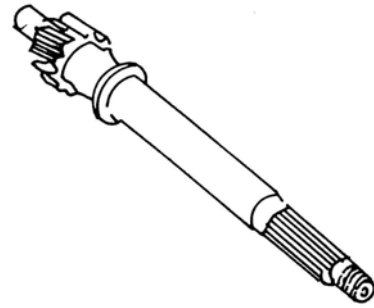

2. Check the wearing condition of idle gear shaft and idle gears.

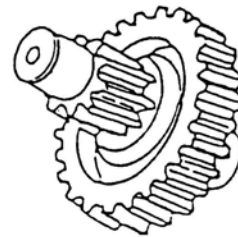

3. Check the wearing condition of the final reduction gear.

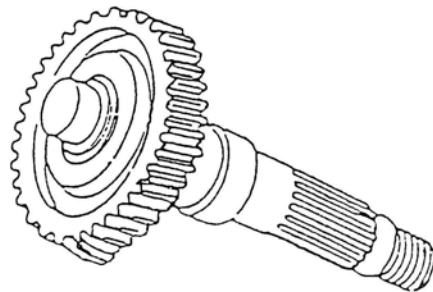

4. Check the wearing condition of the oil seal and bearing.

D. Assemble the final transmission mechanism please follow the opposite procedure of disassembling. After locking the drain bolt, refill 110cc of gear oil SAE90.

6.1 Front wheel demolition

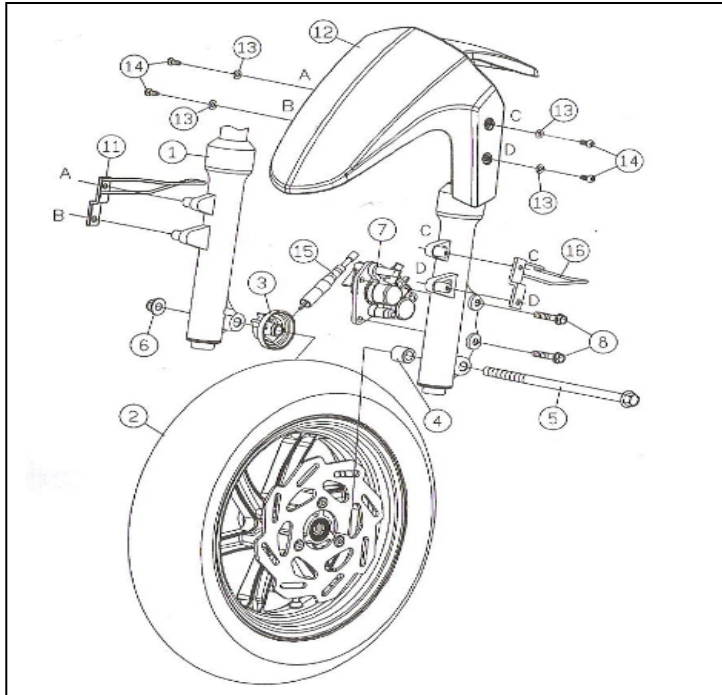

Steps:

1. Remove the "5" front brake bolts * 2.
2. Remove the front axle nut "6".
3. Remove the "5" front axle "4" spacer ring "3" code table gear and "2" wheels.

Torque: Parts5- 5.0~6.0kg-m

6.1.1 Front wheel measure

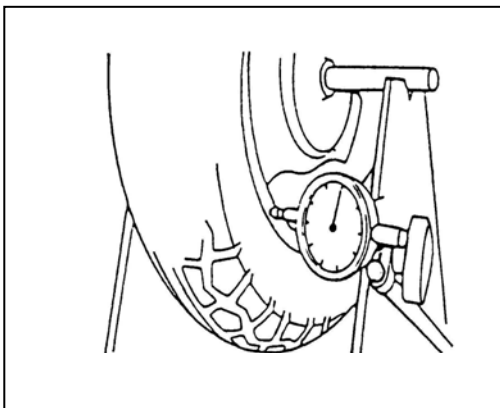

Measuring -

- › Horizontal direction: $\geq 2.0\text{mm}$
- Vertical direction: $\geq 2.0\text{mm}$
- Beyond the limits - replace

Shock absorber / brake system/wheel - 6

6.1.2 Front wheel -One sealed ball bearing

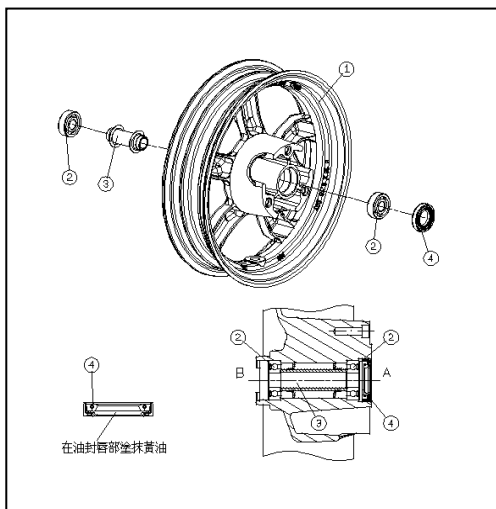

>Demolition -

Tool: Bearing Removal Tool

Demolition of oil seal tool

Specification: Sealed ball bearing 6201

- 1) Use Oil seal tool demolition oil seal demolition.
- 2) Use of the bearing removal tool will hammer out the single sealed ball bearings.

> Check-

1.Bearing

Rotating ring true and different sound → Replace the ball bearings.

2.Oil seal

Specification:22-35-7

Wear, damage→replace



>Installation -

Tools - Bearing removal tool.

- 1.A first bearing does not cover the surface with butter.
- 2 Bearing stamped facing the use of tools bearing knock Entry.
- 3 Oil seal is loaded, installed at the sealing lip painted yellow Oil.

6.1.3 Front wheels - Brake disc



Measurement –

1.Thickness:

Standard values:3.6mm

Use limits: ≤ 3.1 mm

Beyond the limits - replace

2.lost roundness: ≥ 0.3 mm

Beyond the limits - replace

6.1.4 Front wheel – Meter gear assy

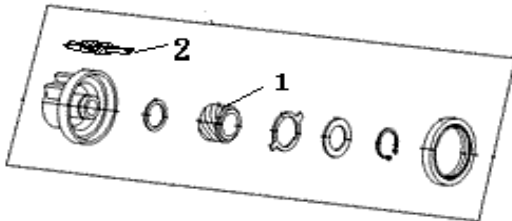

Check -

›Speed meter gear"1"

Pinion speed meter"2"

Wear, damage → Replace the code table gear

6.1.5 Front wheel - Front axle

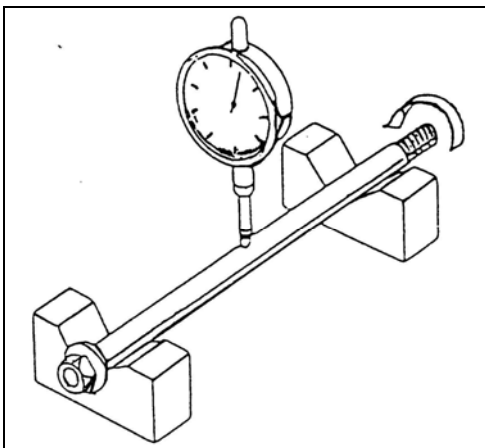

Measurement –

Limit of use: Change it when above 0.25mm.

6.2 Front fork

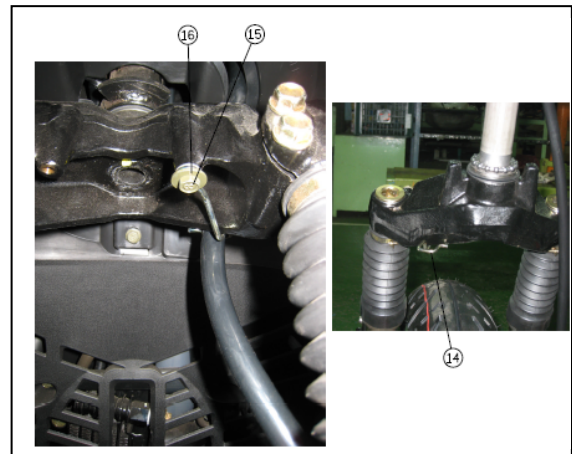
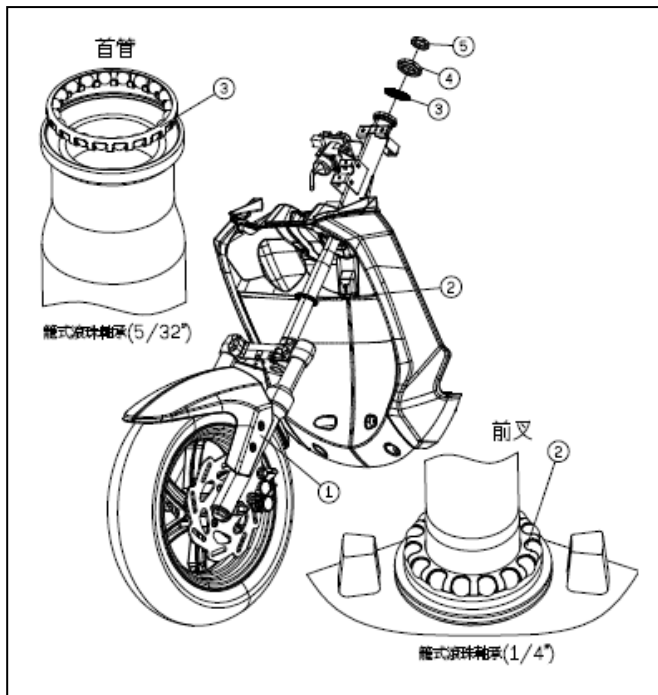

>Disassembly -

Step-

1. Remove the Handle bar.
2. Remove the Front wheel.
3. Remove the front fender.
4. Remove the screws with washers (15),take out the clip (14).
5. Using the front fork disassembly tool · Remove the steering shaft lock nut (5)and Upper ring-shape nut(4).
6. Remove the cage ball bearings (upper and lower)-(2.3).

6.2.1 Ball bearing disassembly

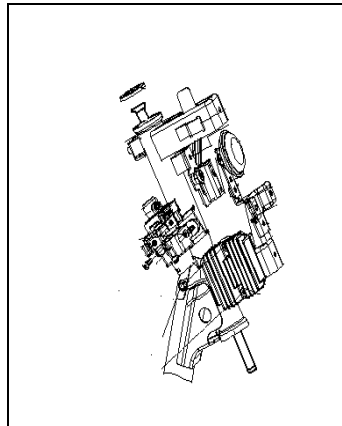
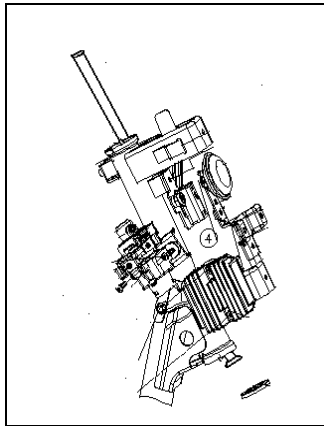

Check -

›Ball bearing cage

Rupture, deformation → replacement.

› Upper ring-shape nut 、 Upper bearing cage 、 Lower bearing cage 、 Inner bearing cage

Wear, deformation → replacement.

Note:

Ball bearing cage and Bearing Rupture depression deformation will cause handle tube rotating flow, and body shaking unstable.

Tools –

Fork bearing disassembly tool

Demolition -

The use of impact rod will “upper bearing cage ”and
”lower bearing cage” Qiaoxia.



Installation –

1. First “upper bearing cage ”and” lower bearing cage” Parallel pressed into.
2. Use Fork bearing disassembly tool Will be “upper bearing cage ”and” lower bearing cage ”slowly turn Into the vehicle inside the station.
- 3.Check“upper bearing cage ”and ”lower bearing cage” Whether there is smooth.

。

6.3 The front fork assembly installation

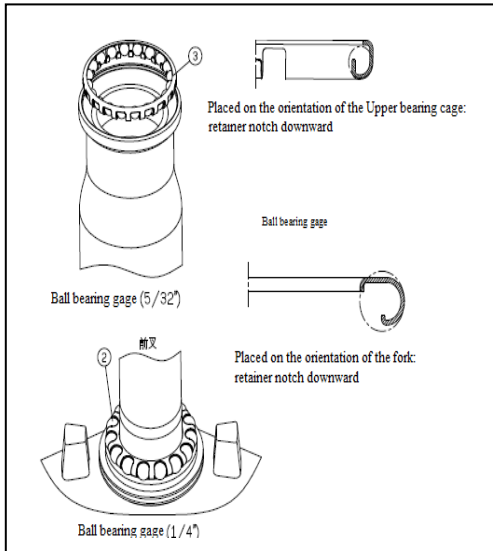

Installation –

1. Ball bearing gage (up / down) for Smear the butter.

Note: Ball bearing gage direction, the installation can no be wrong .

2. front fork assembly installation-

Front damper can be installed in accordance with demolition reverse (See the chapter 6.2).

Step:

- 一. The hand will upper ring-shape nut locking , Using fork disassembly tool to the Leftward and then tighten about 1/4 to 1/2 turn.

- 二. The hand will upper ring-shape nut locking, using fork disassembly tool fixed steering shaft lock nut and upper ring-shape nut.

- 三. Will be upper ring-shape nut locking rightward.

- 四. Check the front fork can not be too loose or too tight.

3. Install the front fender and front wheels.

4. Installation on the handle bar.



This side of Upward



This side of Upward



This side of Downward



This side of Downward

Shock absorber / brake system/wheel - 6

6-4 Front suspension assembly

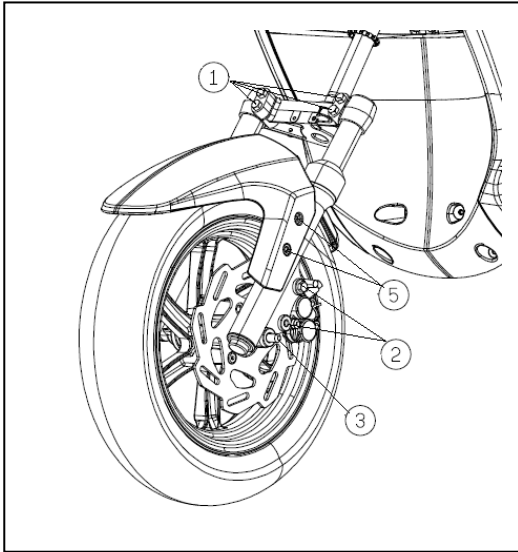

Demolition -

- 1.Remove the brake caliper mounting bolts "2".
- 2 mounting bolts of the front wheels "3" removed, take out the front Axle,spacer , meter gear,front wheels.
- 3 Remove the front fender fixed bolts "5".
4. Remove the left and right damper bolts"1".

Installation –

Front damper can be installed in accordance with demolition reverse.

NOTE:

The front damper has a different sound or too soft, replace the entire set of damper.

6-5 Rear damper

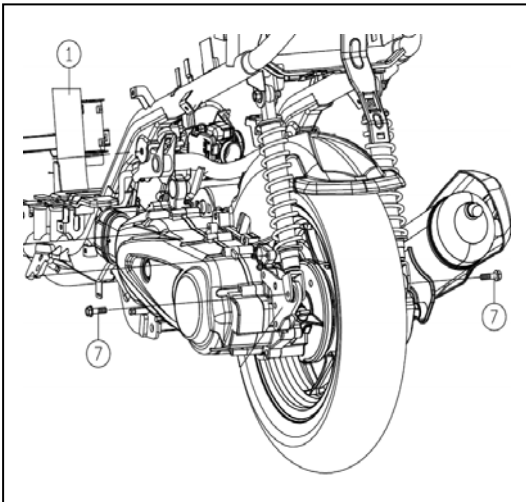

Demolition -

> Right damper

- 1.Remove the hex flange bolts(15) M10-40L.
- 2.Remove the hex flange bolts (7) M8-32 L.

> Left damper

- 1.Remove the hex flange bolts(15) M10-40L.
- 2.Remove the hex flange bolts (7) M8-32 L.

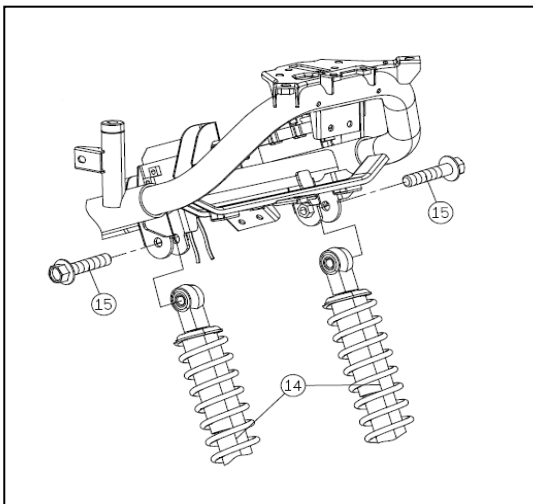

Installation –

After installation in accordance with demolition reverse rear damper can.

Shock absorber / brake system/wheel - 6

6.6 Front wheels - brake pad (disc)

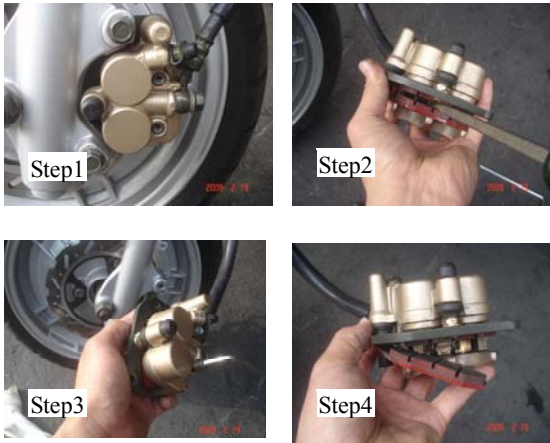

>Disassembly -

Step

1. Remove the screws of the brake calipers * 2.
2. will push the piston back.
3. Remove the screw.
- 4 Remove the yoke springs and brake pads.

>Measurement -

brake pad-

Standard values:5.0mm

Available limits:4.3mm

Lower than the limit - Replacement

Installation -

Brake pad can be installed in accordance with demolition reverse.

6. 6. 1 Rear brake pads

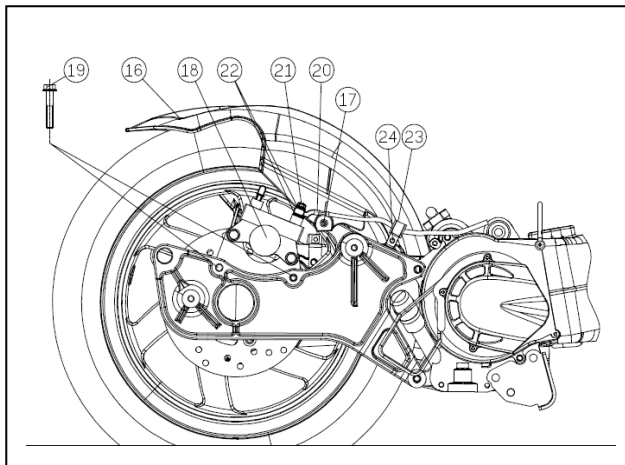

- 1.Remove the screw (19/23), take out the rear brake calipers and brake hose clamp .
2. Using needle-nose pliers to remove the R type retaining ring.
- 3.using needle nose pliers remove the Spring pin.
- 4.Remove the yoke spring and brake pad.

Measurement -

brake pad-

Standard values:5.0mm

Available limits:4.3mm

Lower than the limit - Replacement

Shock absorber / brake system/wheel - 6

6.7 Removing the rear wheel

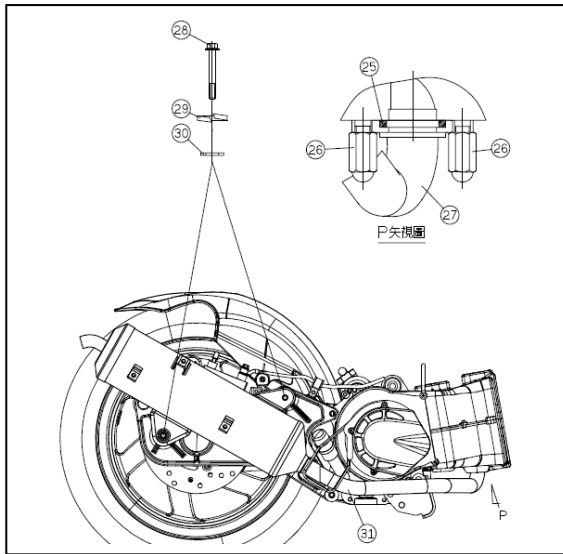

1.Remove the nut / screw / washer (26/28/29/30), take out the muffler (31) and packing (25).

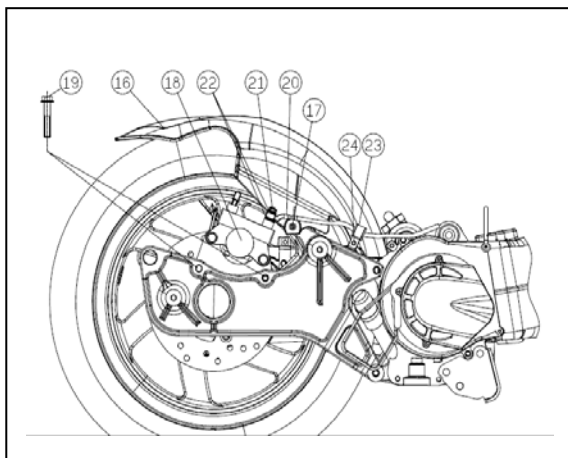

2.Remove the screw (19/23), take out the rear brake calipers and brake hose clamp .

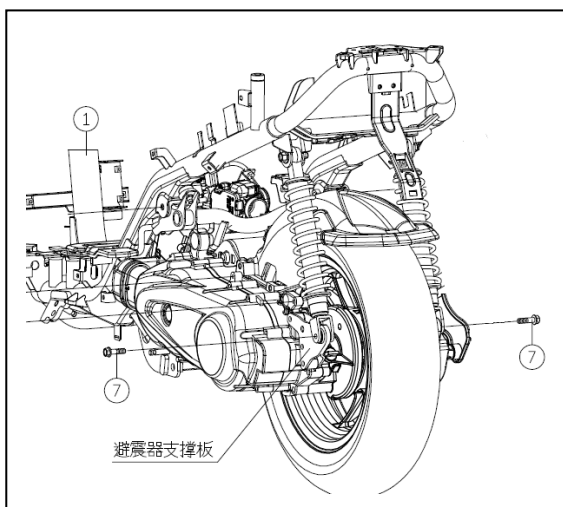

3.Remove the left and right rear suspension screws(7).

Shock absorber / brake system/wheel - 6

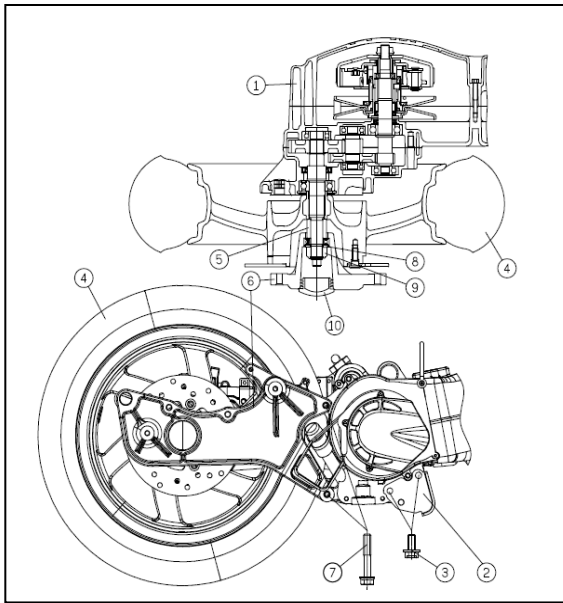

4.1 Use the slotted screwdriver , remove the Rubber (10).

4.2 Remove the flat washer / nut (7/8/9), take out the Rear Swingarm (6).

4.3 Remove the screw(3) , take out the Engine lower hanger (2).

4.4 Remove the rear wheel (4).

6.8 Brake fluid replacement-

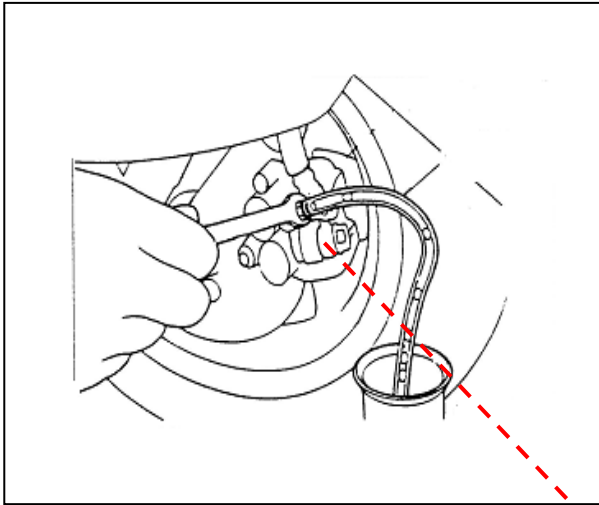

Tools: pumping unit

1. Relax the drain screw.
2. Vacuum pumping unit, taking the dirty oil.
3. Open above the brake master cylinder, pour new oil.
4. Use vacuum pumping unit, out of the air brake tubing.

Please add brake fluid at the same time, do not let the oil cup is taking the time to suck Into the air.

5. Tighten the drain screw and brake master cylinder cover.

The following strut several times to check the brake lever clearance whether Normal, in the absence of a repeat of the action four five.

Warning

Brake master cylinder cover is not installed, do not pull the brake lever, brake fluid will spray accidentally sprayed into the eye and mouth and other important parts, after a large number of rinse with water, and immediately taken to hospital .

Denso component location-

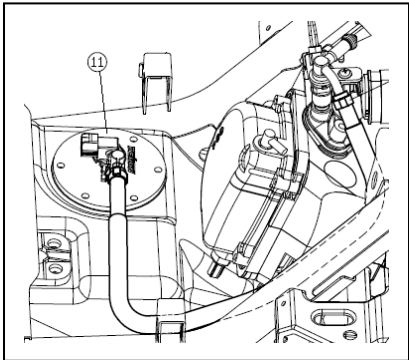

1.FUEL PUMP (11)

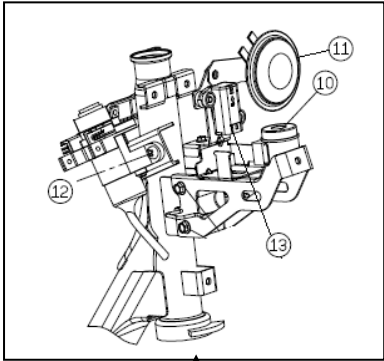

1.FLASHER RELAY ASSY (10)
 2.HORN (11)
 3.IGNITION(MAIN) SWITCH(12)
 4.TOPPLE SWITCH (13)

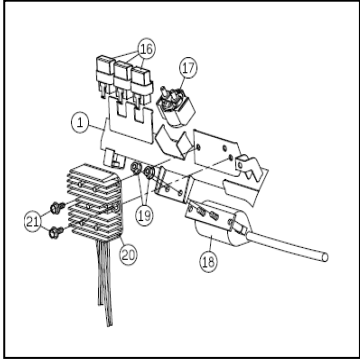

1.RELAY (16)
 2.STARTER RELAY (17)
 3.IGNITION COIL (18)
 4. REGULATE RECTIFIER(20)

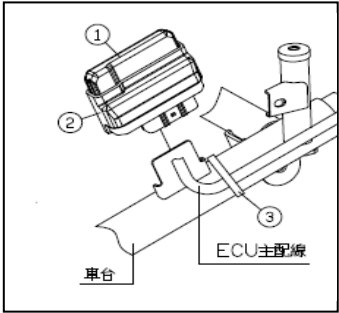

1. ECU(3)

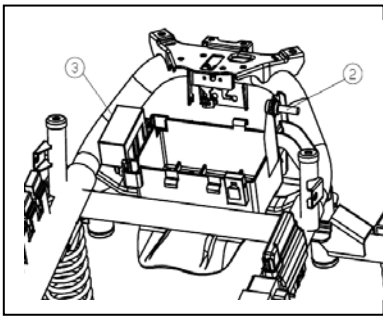
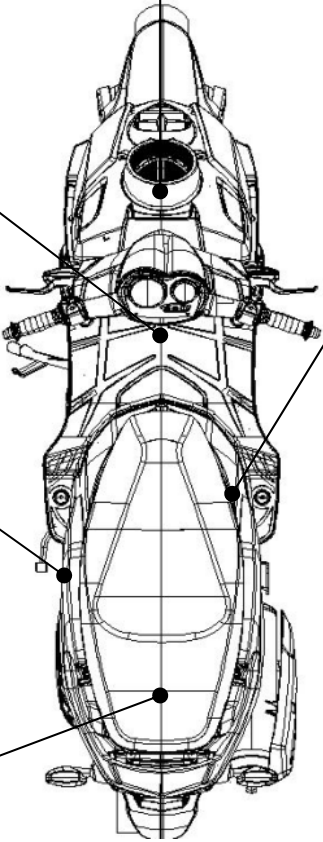

1. DIAGNOSE ADAPTOR (2)
 2. FUSE BOX (3)

Locate the position of the main wiring-

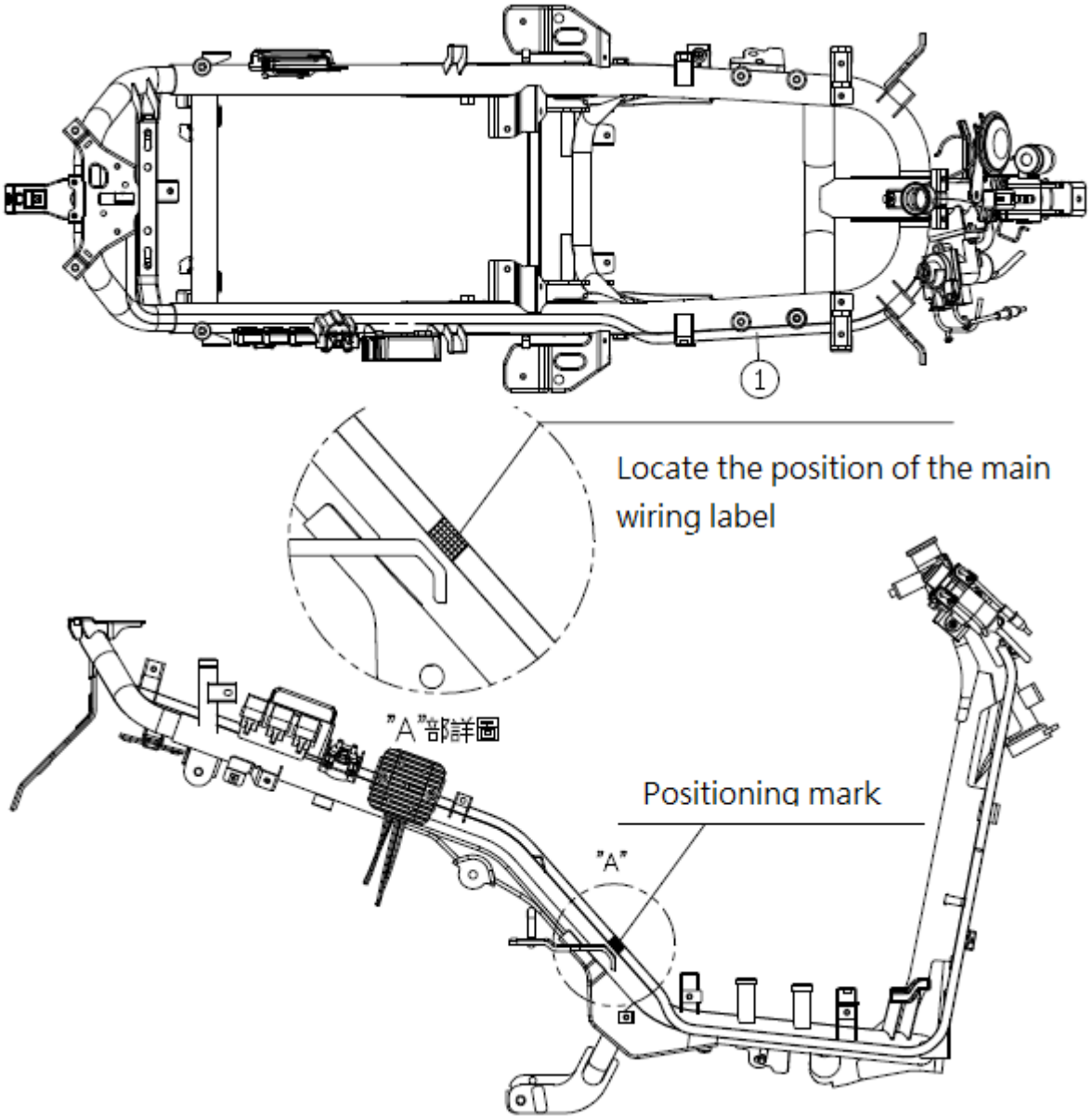

starter system:

Check the process:

- a. fuse → b. Battery → c. start switch → d. start motor → e start relay → f.one-way clutch

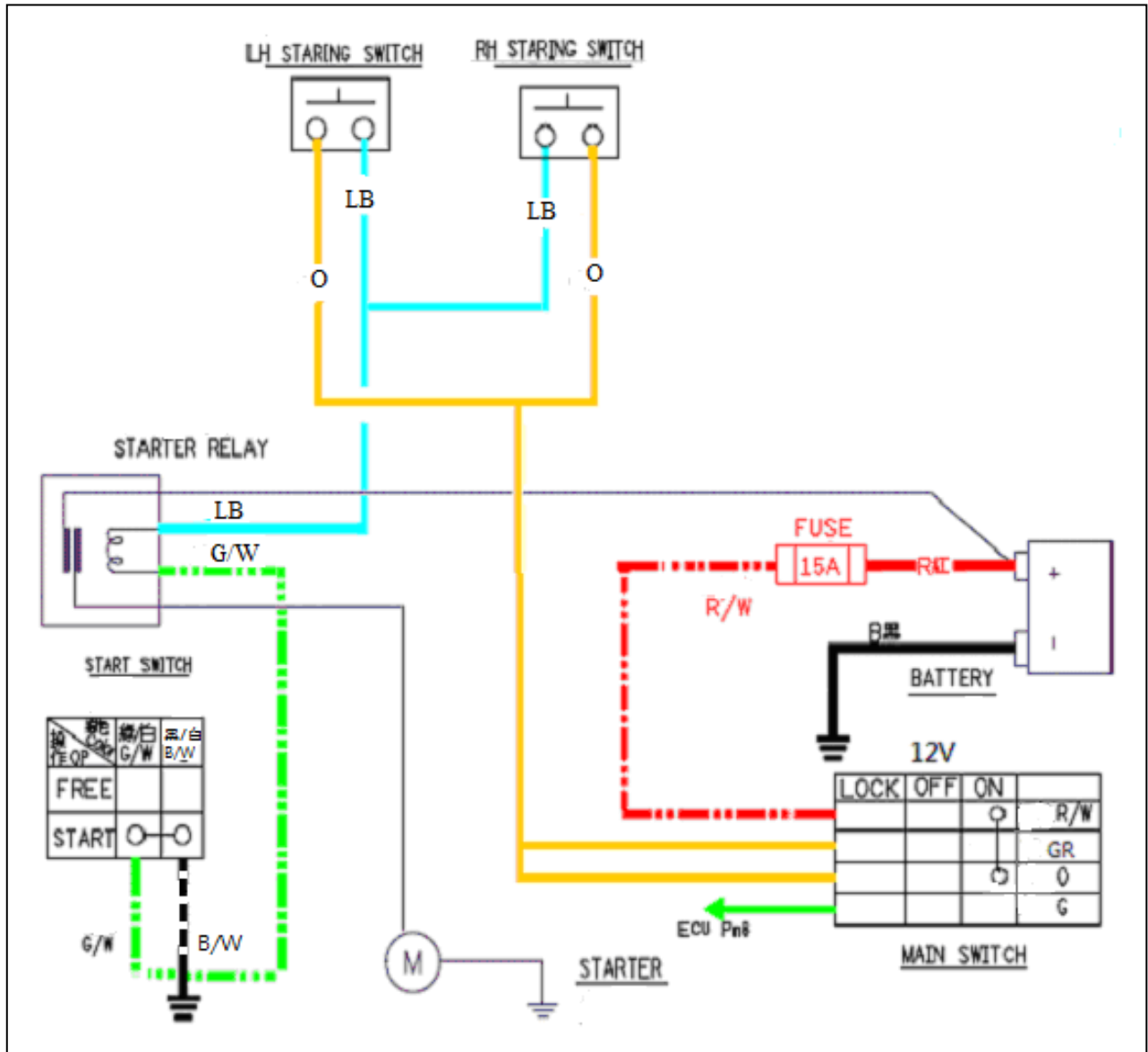

Check the process:

Project	Handle
1. Battery (check the voltage)	12V↓- Please replace or recharge
2.Fuse:(check 15A) KEY the ON	∞-Replace
3.Main switch (KEY ON) Check the line color: Red / White (12V)→ orange (12V)	Red / white, orange = 0V to replace the ignition switch Or line barrier.

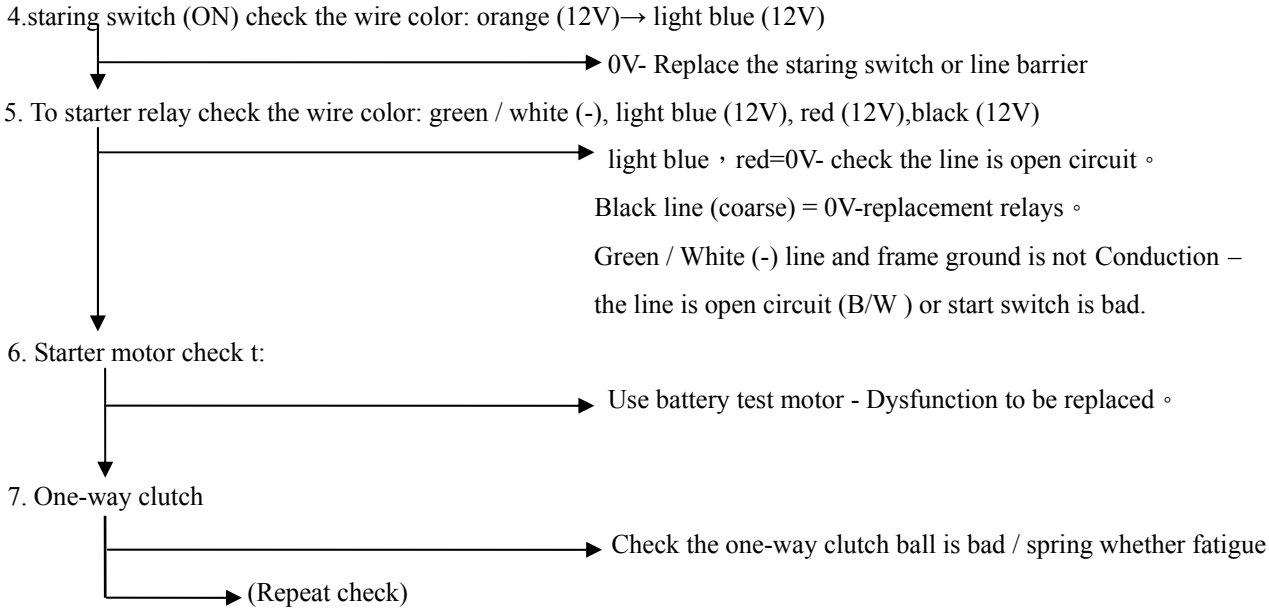

a. Fuse

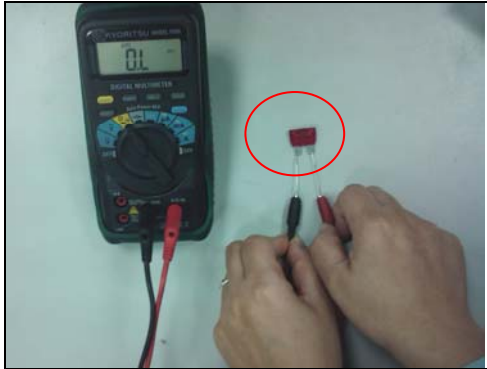

Measurement - 15A fuse broken wire
 > Tools: Three multimeter stalls: Ω
 Use a multimeter probe connected to the fuse pin
 Open circuit (∞) → replacement

b. Battery

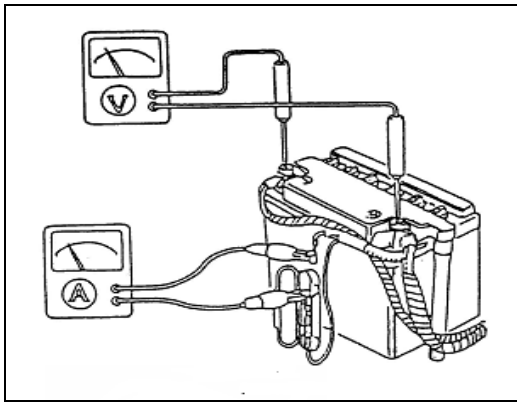

Check -
 > Trailer coupling and cable
 Loose, poor contact → lock, clean

Measurement - battery voltage
 > Tools: multimeter stalls: DCV
 Use a multimeter probe connected to the battery (+, -), pin bit.
 Below 12.3V → Recharge or replace.

c: Brake safety switch



Measurement - switch actuation, continuity

> Tools: multimeter
use multimeter measure the probe is connected to the switch pin .

Measurement	line color	probe	stalls	Judgment	
switch	O	(+)	Ω	conduction	normal
	LB	(-)		∞	replace

e: Starting motor

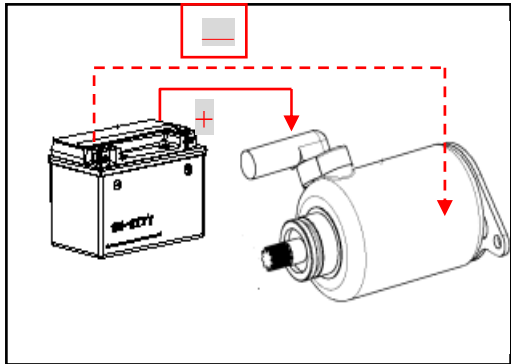

Check - start the motor actuator is normal

> Tools: 12V battery
Method: directly across the 12V voltage to the motor
Not rotate / rotate too slowly → replace

f: starter relay

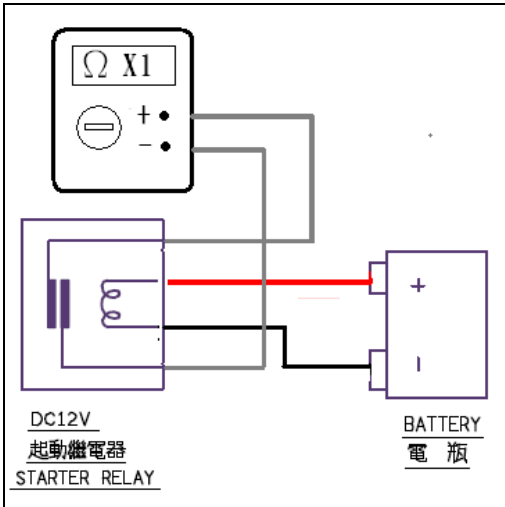

Check - starter relay actuation is normal

> Tools: multimeter (Stalls: $\Omega \times 1$), 12V battery
Ways: using the battery to the relay coil is energized, the measurement relay is turned on
Not conducting → replace relay

7-2 Charging system

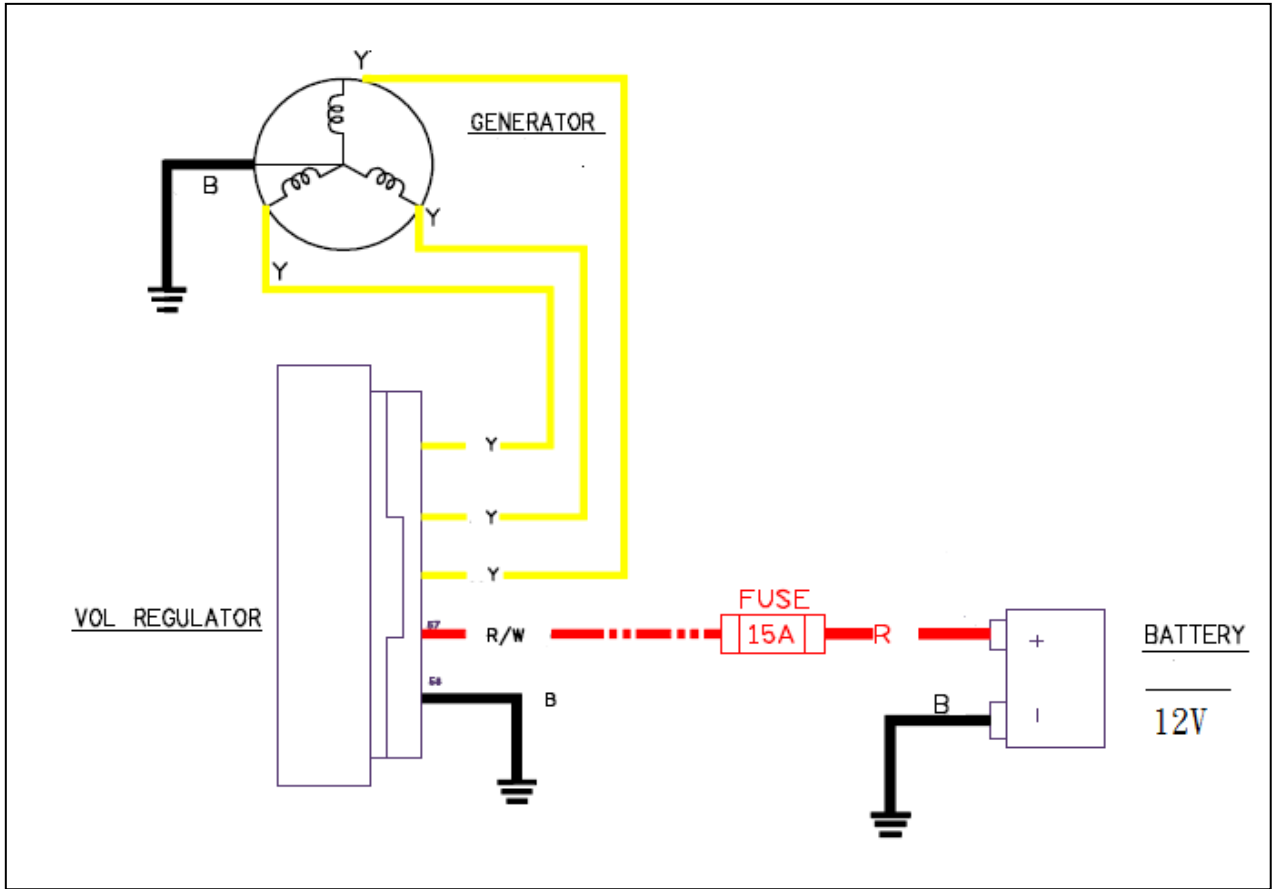

Check the process:

a: battery → b: A.C.G → c: charging line check

a. battery

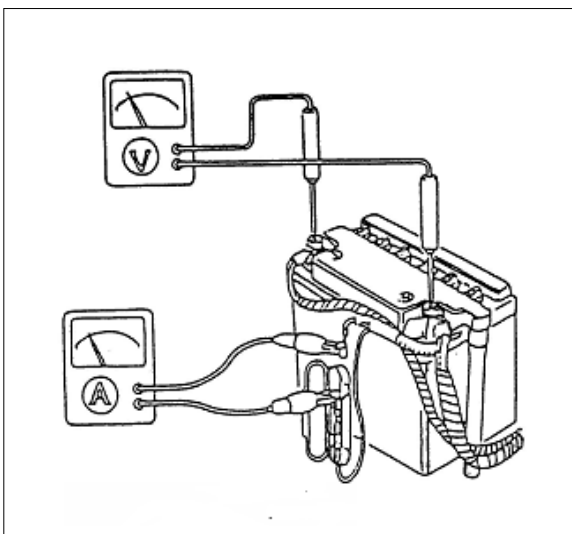

Check - Battery

> Tools: multimeter

Measurement: Voltage: at 20 °C when 12.8V or more

Insufficient voltage → recharged or replaced

Measurement the A.C.G, connect a voltmeter (hook table or pointer).

> Tools: multimeter

Control voltage: 14.2V ± 0.5 at: 2000r/min

★ charging voltage = battery voltage or voltage rose slightly.

→ replace the regulate rectifier or A.C.G

b:A.C.G check

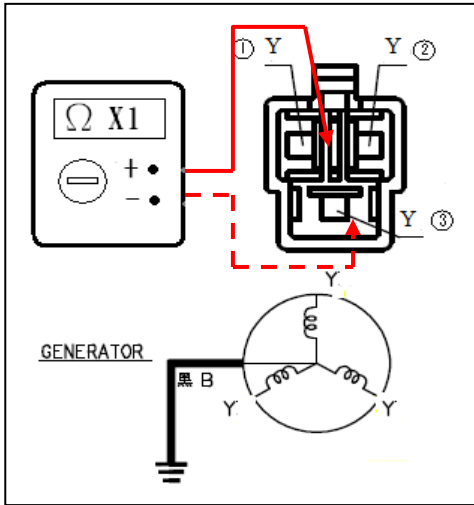

Check-

Tools: multimeter

The measurement-A.C.G rechargeable coil impedance

Measurement	line color	probe	stalls	Judgment	
A C G	1	Y(1)	(+)	Ωx1	0.8±0.2Ω at20°
		Y(2)	(-)		
	2	Y(1)	(+)	Ωx1	0.8±0.2Ω at20°
		Y(3)	(-)		
	3	Y(2)	(+)	Ωx1	0.8±0.2Ω at20°
		Y(3)	(-)		

c: Charging line inspection

Check -

> Each connection line

Open / short circuit, fall off, too loose →Adjustments

7-3 Leakage current testing

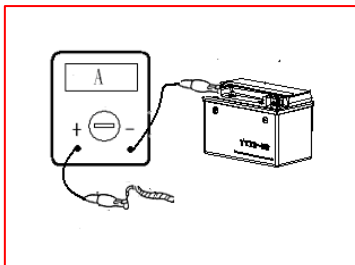

Tools: ammeter (A)

1.Method:Turn off the main switch

2. Negative (-) battery removed

Connect ammeter → probe (+) connection wire harness-
battery negative line

→ Probe (-) connected to the battery (-)

Testing -

> Current

Short circuit leakage 1mA more →

Excluded: electrical equipment connected to the main
wiring contact demolished one by one until you find the
short-circuit location.

NOTE _____

- Measurement can not be turned on main switch
- Ammeter stalls, from large to small sequence adjustment,
avoid excessive current, causing the ammeter or fuse
burned.

7-4 Lamps lighting system

7-4.1- Bulb check

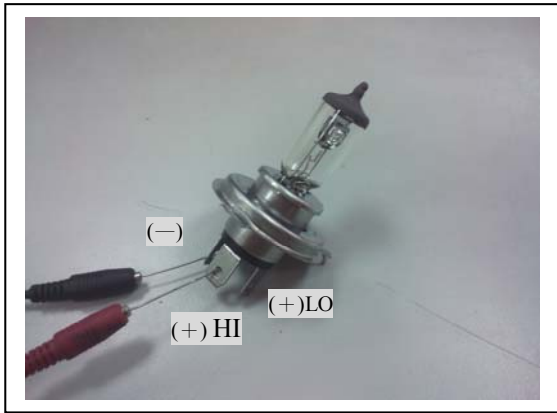

Check - filament whether disconnection

Measurement:

> Tools: Three multimeter stalls: $\Omega \times 1$

Method: Three multimeter measuring rod connected to the three-pin bulb

$\infty \rightarrow$ replace

Measurement: (Figure 13-2)

> Tools: 12V battery stalls: DC 20V

Way: using the battery connection bulbs pin

Bulb does not light \rightarrow Replace

⊙ Measurement Method: (check for all lamps)

Note

- .1. The bulbs just remove the very high temperatures are not directly handling them.
- .2. The bulbs surface is not contaminated with oil or touch the cited to lamp life and brightness. Dirty, use alcohol Wipe clean.

Light switches and line checks

7-4.2 Stop light switch

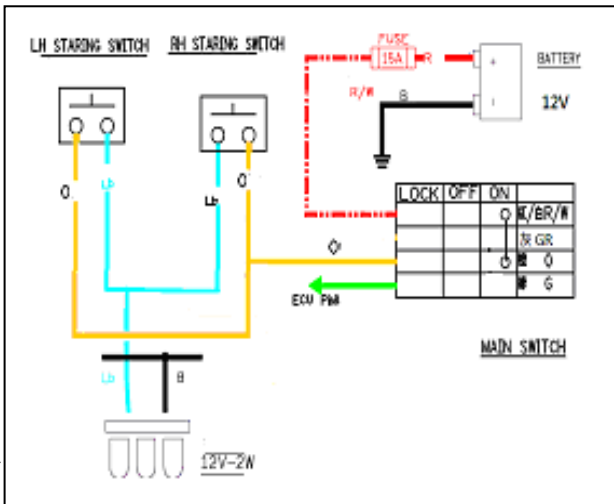

Measurement:

Tools: multimeter stalls: DC 20V

Check the order:

1. Check bulb filament burns out.
2. Measured starting safety switch orange 12V.
3. ON: measured starting safety switch light blue 12V whether.

7-4.3 Headlight / license lamp line loop(Electronic injection version)

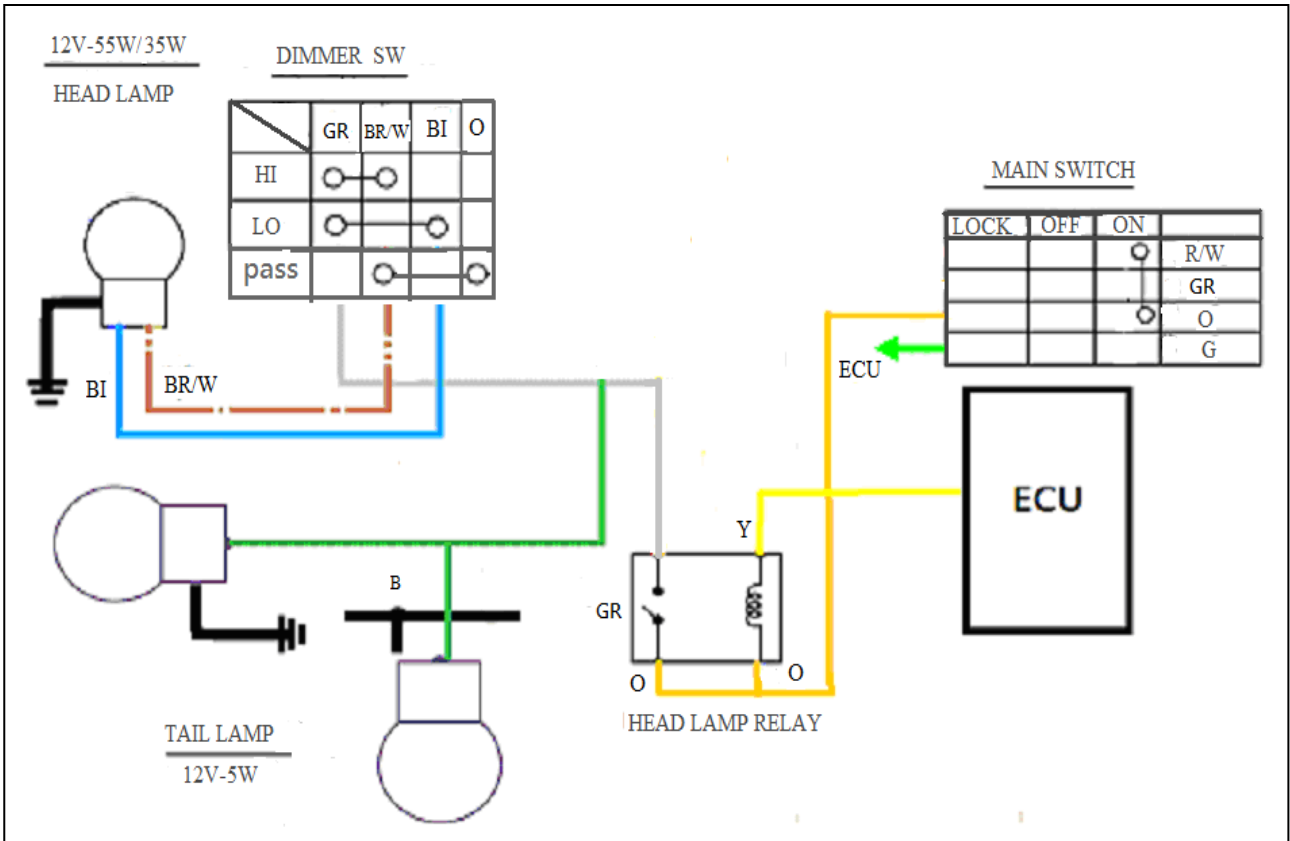

Check the process:

Project	Handle
1. Check the lamp tungsten is not blown	Replacing the Lamp ◦
2. Battery (check the voltage)	12V↓- Please replace or recharge ◦
3. Main switch (KEY ON) check the line color - orange (12V), Red/White (12V)	0V- Replace the main switch or lines open circuit ◦
4. Headlight relay - Orange (12V),yellow(ECU),black(12V), Gray (out) 12V	The orange 0V- open circuit ◦ Yellow (ECU control source)-ECU or lines open circuit. Black 0V-headlight relay replace
5. Dimmer switch checking line color - gray (12V), Blue-12V (LO), brown / white-12V (HI)	Gray 0V - lines open circuit ◦ Blue ◦ brown / white 0V-Dimmer switch replacement
6. Wire assy - (LO) Blue-12V (HI) brown / white-12V, black(-)	Gray 0V- lines open circuit ◦

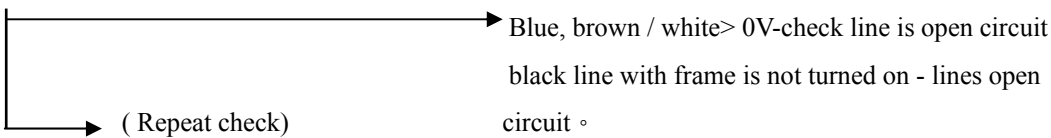

7-5 electrical appliances measurements

›Main switch

Tools: multimeter
Stalls: DC 20V

› line

Key position	Red / White	Orange	Green	Gray
on	12V	12V	330Ω/12V	
	○ _____ ○			
off			○ _____ ○	

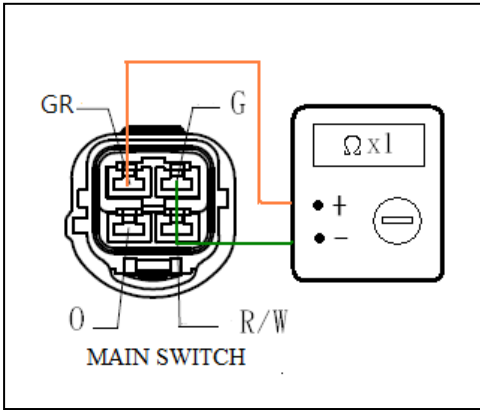

Anti-theft voltage: main switch install a resistor (330Ω) in the gray wire with the middle of the green line, a signal voltage is connected to the ECU, ECU without receiving this voltage or voltage at the same time, the vehicle will not start

›Horn

Tool: Battery 、 multimeter

›Check- line

Items	Line color	Probe	Stalls	Measurement	
Horn	G/Y	(+)	DCV	12V	OK
	B	(-)		0V	NG

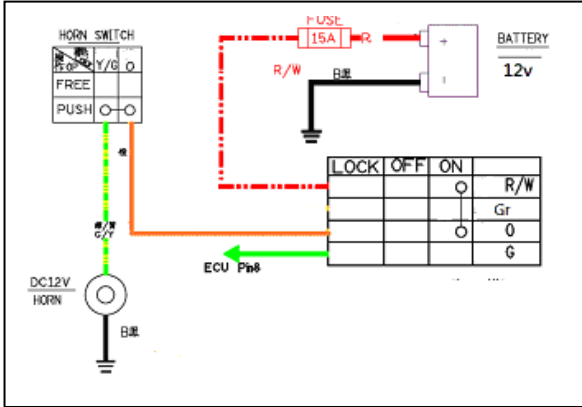

Single product inspection

Way: The speaker two pins connected to the battery

Adverse → no sound or the sound is too small

› Fuel guage

Tool: multimeter

›Check-

Items	Line color	Probe	Stalls	Measurement	
Fuel guage	Gr	(+)	Ω	F:4~10Ω E:80~90Ω	OK
	B	(-)		∞	NG

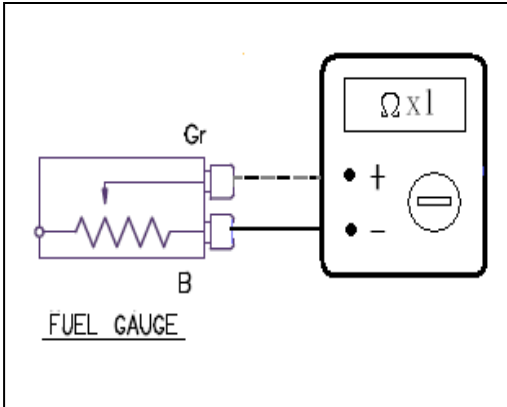

7-6 Control of relays

- * (Relay) 15A
- * theory : use small current to control big current
- * Usage :
 - fuel pump & injector
 - EMS whole system
 - headlamp

*** Relay measurement**

- * use the pocket tester
 1. find the control coil
 2. fit 12V to the control coil
 3. the relay sounds “ka”
 4. measure the resistance<disconnect-->NG connected-->OK<

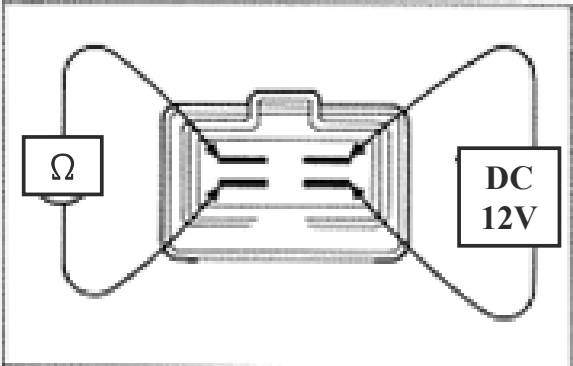
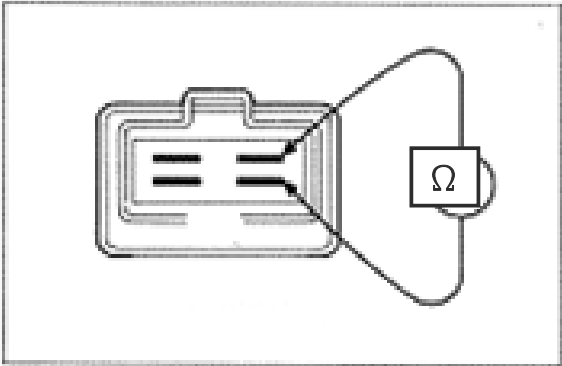
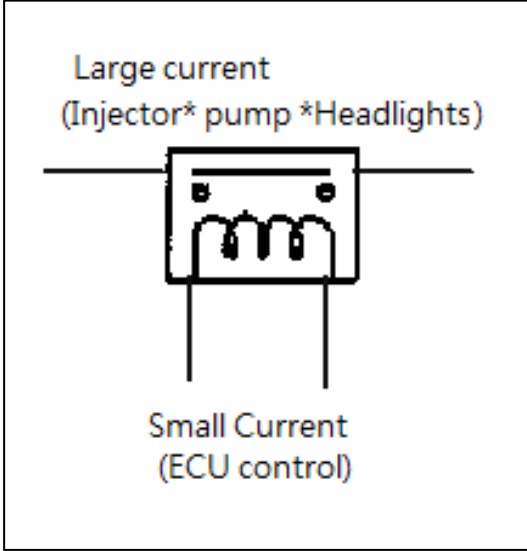

7-7 Fuse Description

(Electronic injection version)-

* Location



* at the right of battery

* dismantle

1. luggage comp.
2. battery cover

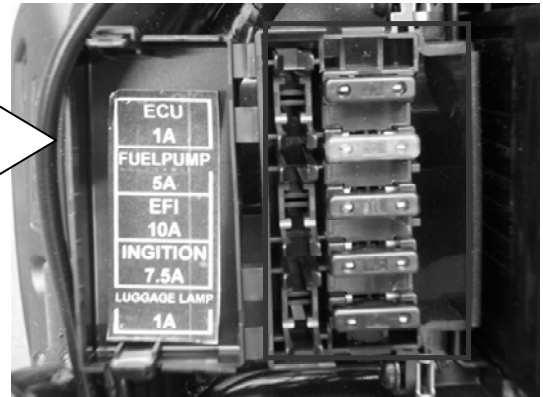

* Description

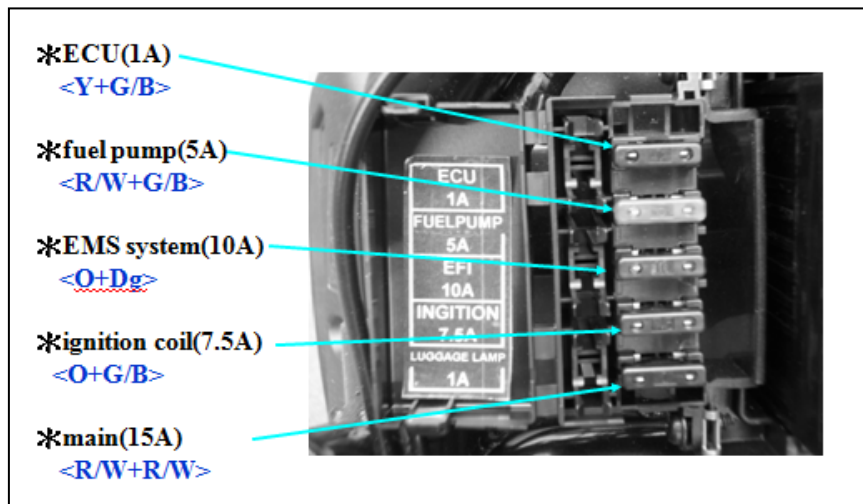

* The main purpose of the fuse

* (FUSE) 1A / 5A / 7.5A / 10A / 15A

protect the units when extra-current occurs

1A : protect the (ECU)

5A : protect fuel pump & injector

7.5A : protect ignition wiring(EMS)

10A : protect EMS system wiring

15A : protect whole vehicle wiring

Warning:

Fuse replacement in accordance with the original specifications replace, not allowed to change specifications and who frequently replace the fuse, check whether the line short-circuit, in order to ensure road safety.

7-8 Associated with the injection system and fuse-

1A: Protection of the microcomputer controller (ECU)

☞ such as the fuse burned

✧ failure phenomenon: Unable to launch, no fuel pump actuator

✧ whether the apparent failure code: no EMS lamp does not light when the main switch is turned on

5A: to protect the fuel pump and injector

☞ such as the fuse burned

✧ failure phenomenon: Unable to launch, no fuel pump actuator

✧ whether the apparent fault codes: (4 long 1 short), the fuel pump circuit anomaly

7.5A: Protecting crystal ignition system line

NOTE: i-ME ~ Xhot

☞ such as the fuse burned

✧ failure phenomenon: Unable to launch, fuel pump actuator

✧ whether the apparent fault codes: (3 7 short and 4 long 5 short), transistor ignition coil failure oxygen sensor circuit anomalies

10A: protection EFI system lines (EMS)

☞ such as the fuse burned

✧ failure phenomenon: Unable to launch, no fuel pump actuator, but the starter motor to continue its normal actuation

✧ whether the apparent fault code: No, ECU power input, there is no signal output to each EFI components, however, it has not fuel injection and ignition

15A: protect the vehicle main wiring line

☞ such as the fuse burned

✧ failure phenomenon: would not start, the whole car without power

✧ whether the apparent fault code; no, because the vehicle without voltage

7-9 Injection system wiring diagram

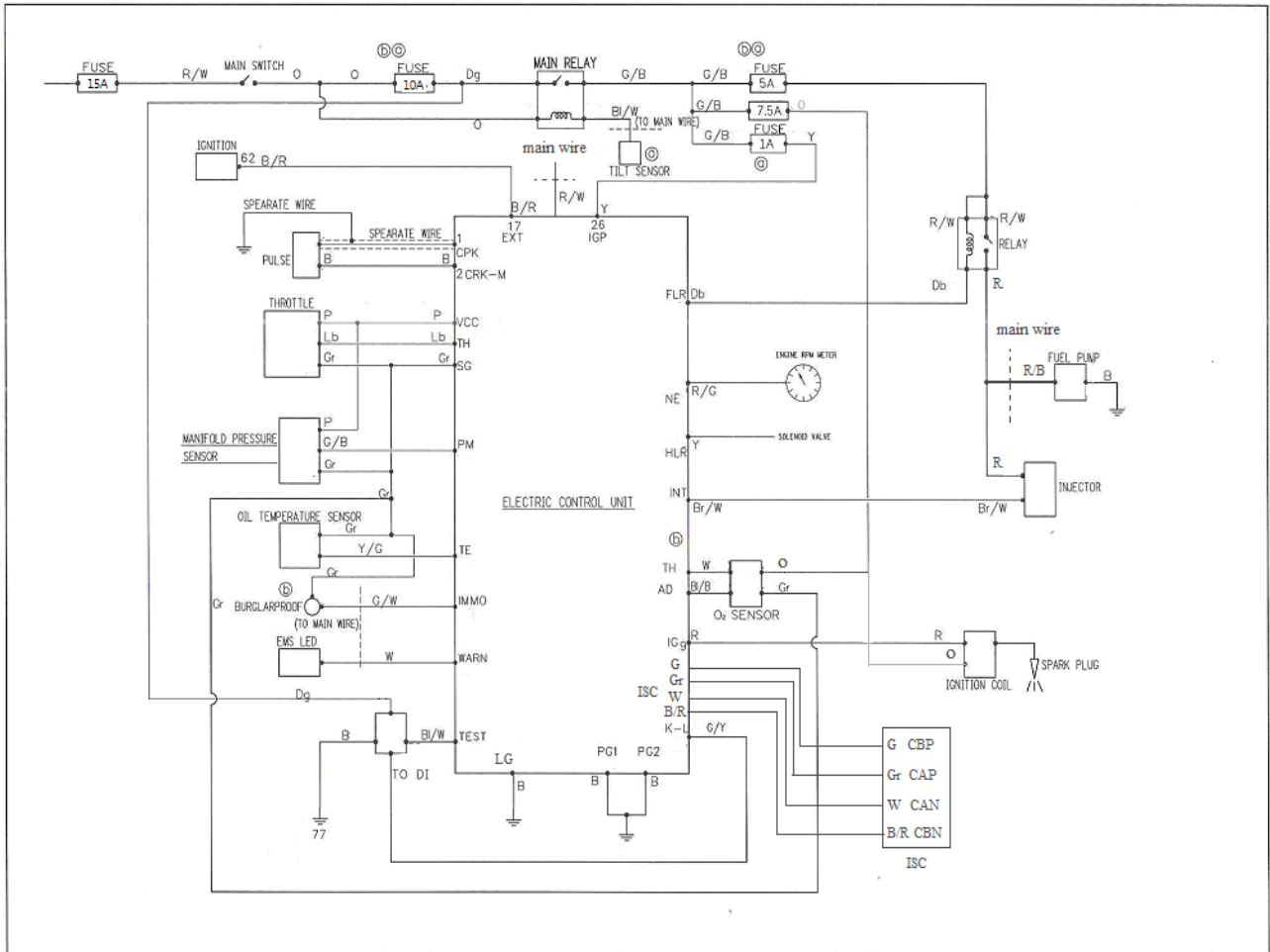

Line color injection system

- 1 gray - Ground
- 2 pink-ECU provides 5V voltage
- 3 red / white - the battery voltage
- 4 Orange – main switch (KEY ON)

7-9.1 Injection system engine misfire / no injection

CHECK	NG
1. Check whether the vehicle lights EMS fault lights? →	Troubleshooting.
2. Check the battery voltage has 12.3V? →	Replace or recharge batteries.
3. Check the fuse if there is broken wire? →	Fuse broken wire replace with new one.
4. Open the main switch to check whether the relay actuation sound? (2 beeps) →	Check the relay is normal?
5. Check the main switch or main relay – orange line if there is 12V voltage? →	Replace the main switch or wire open circuit.
5.1 Check the main switch burglar resistance - green line, gray line whether there 330Ω? →	Replace the main switch.
6. Check the main relay - dark green line, orange line Are there 12V ? →	Check the wiring or fuse (10A).
6.1 Check the main relay - Blue / White line and frame grounding is conducting? →	Check the Toppole switch
6.2 Check the main relay (actuator) - Green / Black line Are there 12V ? →	Check the main relay
7. Check the fuel pump relay - Red / White line Are there 12V ? →	Fuse (5A)
7.1 Check the fuel pump relay - dark green line (ECU ↔ relay) , wire whether the conductive? with the frame whether the conductive? →	wire open circuit or ECU is bad.
7.2 Check the fuel pump relay (actuator) - Red line Are there 12V ? →	Replace the fuel pump relay
(ignition)	
8. Check the ignition coil - red line Are there 12V? →	wire open circuit
8.1 Check the ignition coil -Brown / White line (ECU ↔ ignition coil) whether the conductive? with the frame whether the conductive? →	wire open circuit or ECU is bad.
8.2 Check the ignition coil is normal →	Replace the ignition coil
(Injection)	
9. Check the fuel pump – Red Are there 12V ? →	wire open circuit
9.1 Check the fuel pump -black line and the frame ground whether the conductive? →	wire open circuit
9.2 Check the fuel pump - Are there actuation, hydraulic adequacy? →	Replacing fuel pump
9. Check the fuel injector - Red line Are there 12V ? →	wire open circuit
9.1 Check the fuel injector -Brown / White line (ECU ↔ injector) whether the conductive? with the frame whether the conductive? →	wire open circuit or ECU is bad.